

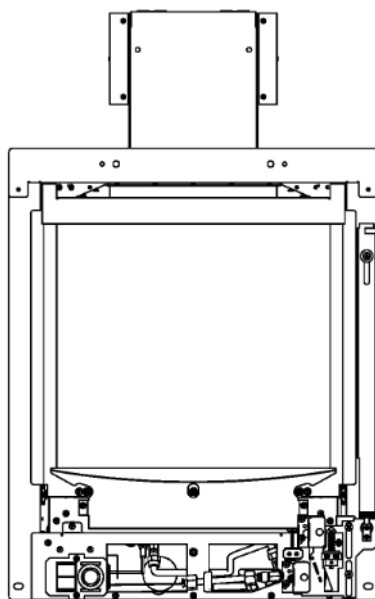

THERMES BALANCED FLUE ROOM SEALED GAS FIRE



USER INSTRUCTIONS INSTALLATION INSTRUCTIONS SERVICE INSTRUCTIONS

Do not use this appliance if the front glass panel is broken, removed or fitted incorrectly.

It is a regulation that these instructions be handed to the customer after installation is complete. It is also the responsibility of the installation engineer to ensure that the customer is able to fully operate the appliance and is aware of any cleaning or maintenance requirements.

Model number: F-071XX1 MANUAL for use on Natural Gas (G20) at a supply pressure of 20 mbar in GB /IE

Model number: F-071XX2 SLIDE for use on Natural Gas (G20) at a supply pressure of 20 mbar in GB /IE

(XX denotes trim type)



THIS INSTRUCTION MANUAL MUST BE LEFT WITH THE CUSTOMER AFTER INSTALLATION

CONTENTS

Appliance Commissioning Checklist	3
Important information & Warnings	4
Regulatory Information and Installation Requirements	5
Appliance Dimensions	6
Unpacking the Appliance	7
Flue Terminal Location	8
Siting the Appliance and preparing opening.....	9
Clearances from combustible shelf.....	11
Elevated installation.....	12
Preparing the gas supply for the appliance	12
Fixing the Appliance and the Flue.....	13
Fitting the Terminal and Terminal Guard	16
Appliance Data Information.....	18
Removal of glass panel.....	19
Installing the Ceramic Fuel Bed	20
Lighting the Appliance	23
Completing the Installation	25
Cleaning Instructions	26
Running In and Trouble Shooting	27
Service Instructions	28
Product Fiche	40
Spare Parts List	41
Manufacturer's Contact Details	41

APPLIANCE COMMISSIONING CHECKLIST

It is the installers responsibility to complete the following checklist when commissioning this appliance. The information recorded on this page may be requested at the time of any warranty call made. If the information is not made available it may affect the warranty support for the customers appliance.

CHECK LISTS	PASS	FAIL
Check flue is suitable for this appliance		
Check flue flow prior to installation		
Check spillage after installation		
Check standing gas pressure		mbar
Check working pressure on full rate (Min. 18.5) Ensure all other gas appliances are running on full rate		mbar
Complete relevant section of warranty forms , ensure it is complete with Gas Safe registration details.		
Instruct the customer on lighting, maintenance and servicing procedures. (Including glass removal and ceramic placement)		

Appliance Serial Number	
Installation Date	
Gas Engineer Name	
Gas Safe Engineer Registration No.	
Gas Safe Engineer contact No.	

DATA PLATE LOCATION

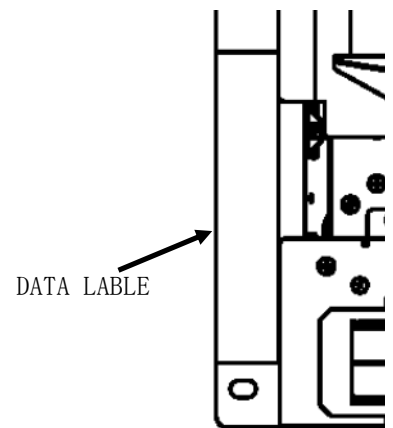

If you can smell gas, immediately turn off the gas supply using the control valve at the meter in your home. Do not smoke and turn off all sources of ignition, i.e. boilers or gas hobs. Open windows and doors to ventilate the room or building.

Call the Gas Emergency Service 0800 111 999 (England Scotland and Wales)
0800 002 002 (N. Ireland)

Welcome

2.0 Congratulations on the purchase of your new Wildfire THERMES balanced flue gas fire. Ensure you keep these instructions in a safe place as they will be required for installation, service and general upkeep of your appliance.

These instructions should be followed precisely to ensure that you receive many years of trouble free service from your appliance.

Some general maintenance is required by the user to keep the appliance in its best condition, these are detailed later in this instructions manual.

Warnings

Do not place soft wall coverings (i.e. embossed papers etc,) furniture or other combustible items too close to the fires as they may discolour or scorch.

Do not place or throw rubbish or otherwise on the fuel-bed.

Do not place any combustible materials or flooring (i.e. carpets etc,) on any part of the hearth.

Many parts of this appliance and some surrounding areas will be come hot during use.

This appliance has a naked flame and as with all heating appliances a fireguard should be used for the protection of children, the elderly and infirm. The fireguard should conform to BS8423 : 2002 (Fireguards or use with Gas Heating Appliances).

It is quite normal for a flame effect gas appliance to experience a small amount of soot or staining to some parts of the fuel effect components. If this becomes excessive it may be because the fuel bed is not fitted correctly — this should be checked according to these installation instructions prior to contacting a service engineer.

NEVER place any rubbish or otherwise onto the fire—this will affect the way the product operates and may affect the warranty of the product.

NEVER place more ceramic components onto the fuel bed than specified in the instructions.

NEVER touch the ceramics when the appliance has recently been switched off—these components retain heat and may cause burns. Leave the appliance to sufficiently cool prior to any contact of the ceramics.

Ventilation

No purpose made ventilation is normally required for this appliance when installed in G.B. Ventilation areas (if applicable) should be checked periodically to ensure there is no obstruction, even though none is normally required for this appliance.

Regulatory
Information

NOTE THE FOLLOWING PRIOR TO THE INSTALLATION OF THIS APPLIANCE.

This gas appliance **MUST** be installed by a GAS SAFE registered installer by law. It must be installed in accordance to these installation instructions and the GAS SAFETY (Installation & Use) REGULATIONS 1998 as amended. Non compliance of this law may lead to prosecution and it is in the interest of you and your family that this condition is observed.



Check for the Gas Safe logo on your gas engineers membership card.

The installation of this appliance must be in accordance with the relevant parts of the LOCAL AND NATIONAL BUILDING REGULATIONS as issued by the Department of the Environment or BUILDING STANDARD (Scotland Consolidation) REGULATIONS issued by the Scottish Development Department and the following relevant British Standards:

- BS5871 Part 2 Installation of Inset Live Fuel Effect Gas Fires
- BS5440 Parts 1 & 2 Installation of Flues and Ventilation
- BS6891 Installation of Gas Pipe-work
- IS813:1996 Domestic Gas Installation (Republic of Ireland)

If the product is being installed into a timber framed building then advice should be sought specifically as building alterations may void any cover supplied by NHBC. If in doubt contact your local building and planning authority. Further information can be obtained from the publication: Gas Installations in Timber Frame Buildings : IGE/UP/7 Edition 2.

Efficiency
/Technical

The efficiency of this appliance has been tested to EN613 and the result is 86.4% net (77.8% gross). This efficiency value has been verified by Kiwa (0558). This efficiency value can be used for SAP (Standard Assessment Procedure) for energy rating of UK dwellings.



Appliance Technical Information

GAS TYPE: NATURAL	GAS CATEGORY: I _{2H}	INLET PRESSURE: (COLD)20mBar
HEAT INPUT: GROSS 4.2kW	INJECTORS: 1.62	DESTINATION COUNTRIES: GB / IE

Installation
Requirements

Prior to installation ensure that the gas supply is compatible with the appliance, this appliance must only be used on **natural gas** at a supply pressure of 20 mbar as marked on the data plate on the appliance and the carton.

This appliance must only be installed in accordance with BS5440: Part 1 and these installation instructions.

For minimum and maximum flue dimensions refer to page 9 of these instructions. The horizontal flue section only should be modified by the installer to suit the installation, no modification should be made to the flue terminal. The guard (supplied) must be fitted to the terminal if any part of the terminal is below 2 metres above any accessible point, i.e. the ground or balcony etc.

Site Requirements

Do not place soft wall coverings (i.e. embossed papers etc,) furniture or other combustible items too close to the appliance as they may discolour or scorch. Do not place or throw rubbish or otherwise on the fuel-bed.

It is very important that you arrange for a GAS SAFE registered engineer to service your appliance every year – This is important for you and your families safety.

NEVER place more ceramic components onto the fuel bed than specified in the instructions.

NEVER touch the glass panel or metal parts surrounding the glass when the fire is running or if it has recently been in operation—these components retain heat and may cause burns. Leave the appliance to sufficiently cool prior to any contact.

WARNING: This appliance has very hot surfaces when in use and as with all heating appliances a fireguard should be used for the protection of children, the elderly, infirm and pets. The fireguard should conform to BS8423 : 2002 (Fireguards or use with Gas Heating Appliances).

Hearth

This appliance must only be installed on to a suitable hearth with a minimum thickness of 12mm. The appliance must not be installed directly onto carpet or other combustible floor materials. The fireplace surround (back-panel) must have a temperature rating of at least 150°C.

Gas Supply

This appliance is suitable for use on natural gas (G20) only from a governed meter. It is the responsibility of the installer to ensure that correct pipe sizing has been supplied to the site for correct performance. 8mm diameter ductile copper tubing should be used for the run to the appliance at a maximum length of 500mm to avoid pressure drops. The appliance is supplied with a isolation device which must be used as part of the installation. There should be no soldered joints within the firebox of the appliance.

Appliance Dimensions

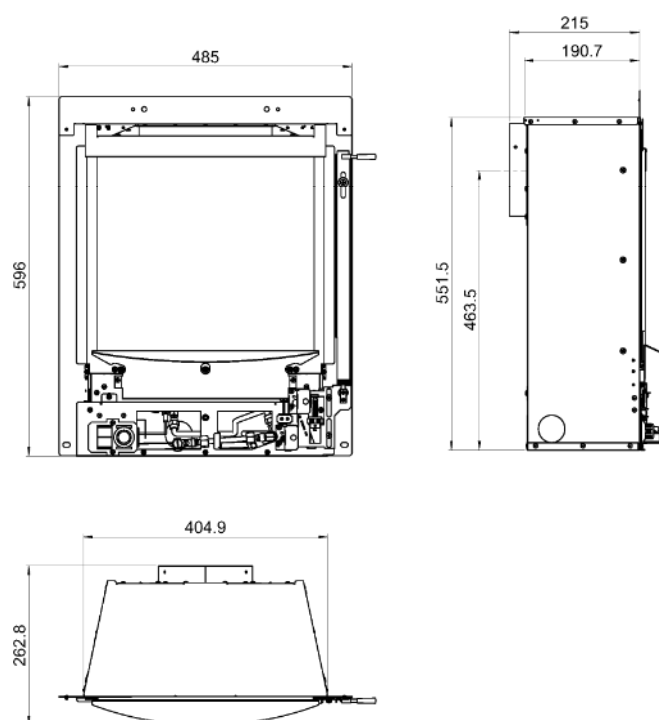

**Unpacking
appliance**

THIS APPLIANCE IS SHIPPED IN TWO CARTONS. CARTON ONE CONTAINS THE APPLIANCE AND CARTON TWO CONTAINS THE FLUE KIT. ENSURE YOU HAVE BOTH CARTONS BEFORE PROCEEDING WITH THE INSTALLATION.







TAKE GREAT CARE WHEN UNPACKING THE APPLIANCE—SOME PARTS CAN BE EASILY DAMAGED.

Once each carton has been opened, carefully remove the polystyrene packing components to reveal the appliance or flue kit. Carefully remove from the packaging then remove and check the accessory packs before commencing the installation.

There will be three plastic bags also located in the cartons:

Instructions and guarantee registration form. Note that the guarantee registration can be performed online at:

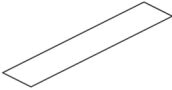
www.hearthproducts.co.uk/register-new-product/

FITTINGS PACK FOR FIRE			
Item	Picture	Description	Qty
1		Fire Retaining Cable	2
2		Knob	1
3		Eyebolt	2
4		Rubber Grommet	1
5		Foam Seal	1
6		Aluminum tape	1
7		Isolation Elbow	1
8		Magnet	2



FITTINGS PACK FOR FLUE			
Item	Picture	Description	Qty
1		Aluminum tape	1
2		Wooden Wall Plug	8
3		ST5*40 Wood Screw	8
4		ST3.9*6.5 Screw	15
5		Terminal Guard Retainer	1
6		Washer	4

REGULATORY REQUIREMENTS FOR FLUE TERMINAL LOCATION
THE FOLLOWING MUST BE NOTED PRIOR TO THE INSTALLATION OF THIS APPLIANCE.

- Terminal without guard
- ⊗ Terminal likely to require flue guard

Figure 1

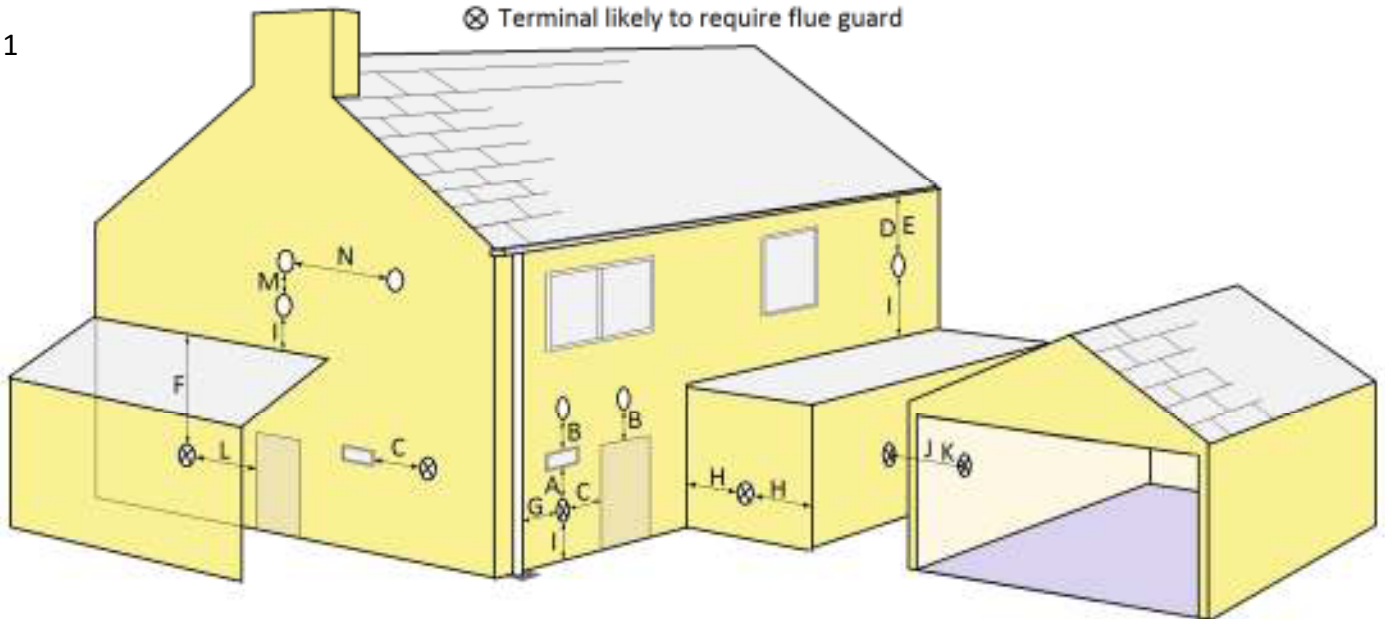

Key	Terminal Position	Minimum Distance
A*	Directly below an opening, airbrick, opening window etc.	300mm
B*	Above an opening, air brick, opening window etc.	300mm
C*	Horizontally to an opening, air brick opening window etc.	300mm
D	Below gutters, soil pipes or drains.	300mm
E	Below eaves.	300mm
F	Below balconies or car port roof.	600mm
G	From a vertical drain pipe or soil pipe.	300mm
H**	From an internal or external corner	600mm
I	Above ground, roof, or balcony level.	300mm
J	From a surface facing the terminal.	600mm
K	From a terminal facing a terminal	600mm
L	From an opening in a car port (e.g. door, window) into dwelling.	1200mm
M	Vertically from a terminal on the same wall.	1500mm
N	Horizontally from a terminal on the same wall.	300mm

* In addition, the terminal should not be nearer than 300mm to an opening in the building fabric formed for the purpose of accommodating a built-in element such as a window frame or door frame.

** The reference to external corners does not apply to building protrusions not exceeding 450mm, such as disused chimneys on external walls.

A terminal guard is supplied with this appliance. It is a requirement in England and Wales that this a guard be fitted where the flue terminal may come into contact with people near the building or be susceptible to damage.

In the republic of Ireland the installation must conform to the relevant sections of IS813 'Domestic Gas Installations'.

Hearth Products recommend that the terminal guide be fitted in any area where it may be damaged or contact could be made with the flue terminal.

SITING THE APPLIANCE AND PREPARING THE OPENING

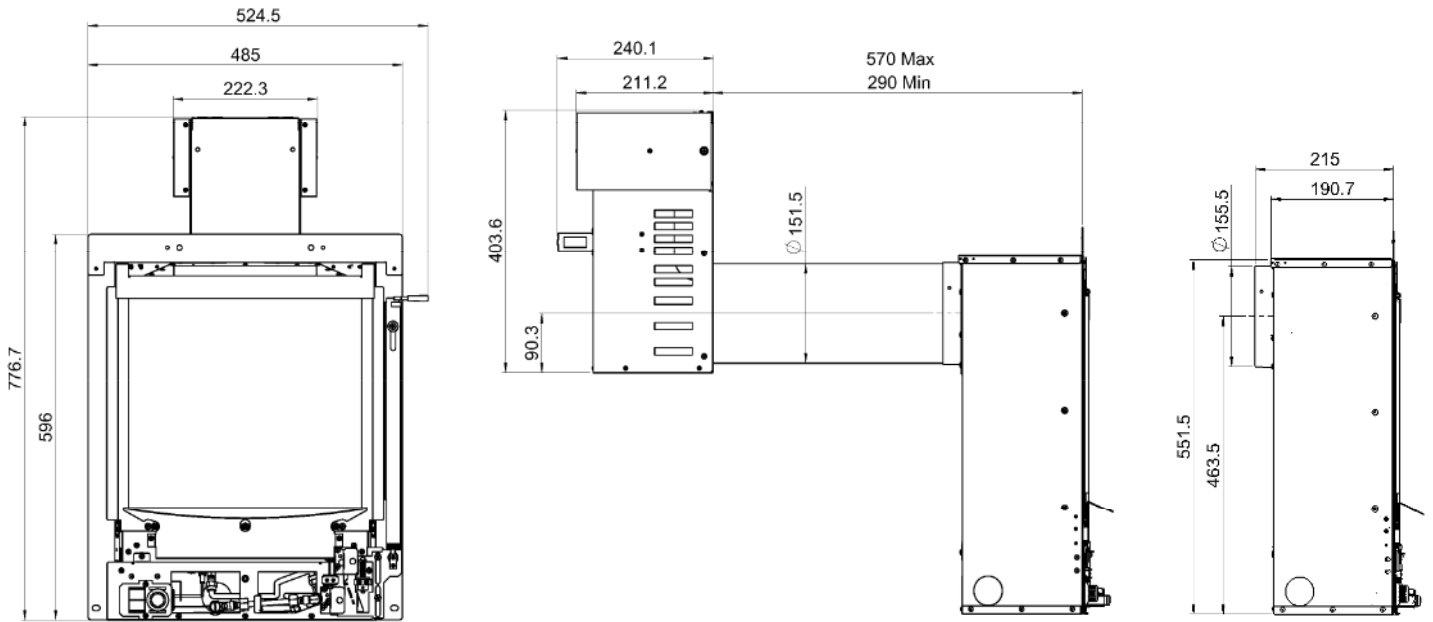

Figure 2

Figure 2 shows the maximum length flue attached to the appliance. If the distance from the front face of the back panel to the outside wall exceeds 570mm the installation cannot proceed. In most installations the flue section will need to be cut to the appropriate size. Any reduction to flue length must be removed from the end opposite the terminal and the three holes then re-drilled to fix the flue to the appliance—use the holes in the waste section of flue as a guide. Take note of the orientation of the flue pipe as it should be installed correctly—see marking on flue.

DO NOT CUT THE FLUE YET. ONCE THE APPLIANCE CAN BE PLACED IN POSITION THE FLUE LENGTH CAN BE CHECKED BEFORE CUTTING—REPLACEMENT FLUES WILL BE CHARGED FOR IF THE FLUE IS CUT INCORRECTLY.

FLUE CUTTING INFORMATION IS ON PAGE 13 OF THESE INSTRUCTIONS

Figure 3 shows the inner brickwork removed to accept the appliance. Note centre of the flue hole must be 6" (minimum) diameter and located at a height of 463.5mm from the hearth or installation surface. Use the template supplied to aid the installation—see page 10 of these instructions.

A clearance of at least 3mm must remain between the rear face of the appliance and the inner face of the outer brickwork—as shown below.

Figure 3

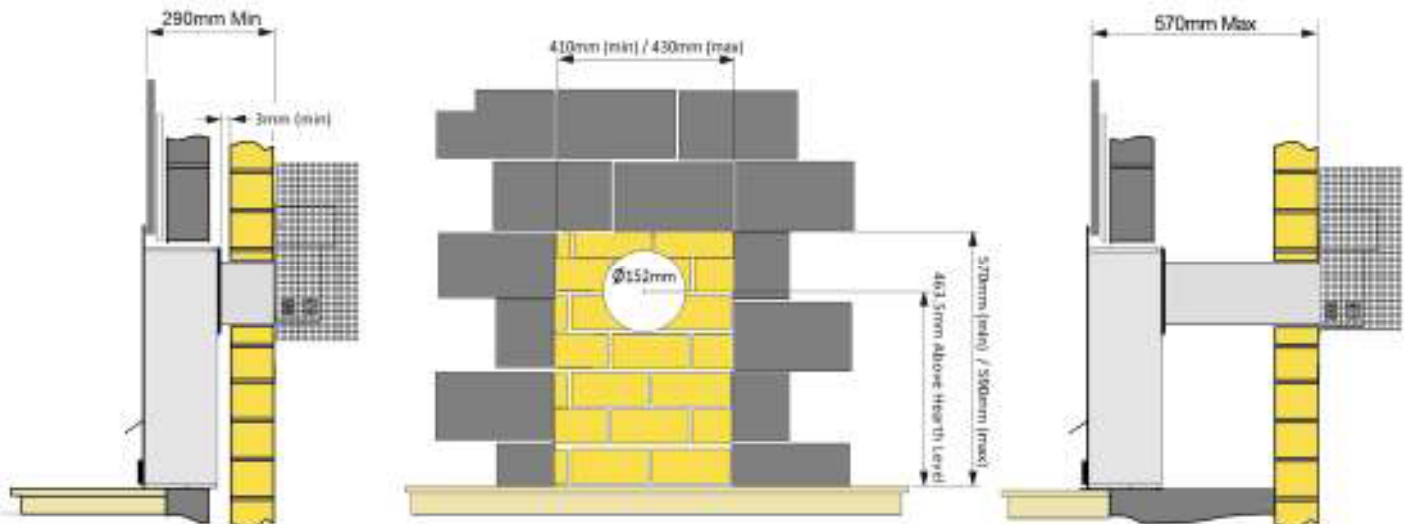

It may be necessary to install a lintel above the cavity that has been created. If a lintel is required to support the recess in the inner leaf (brickwork) then it should either be steel or reinforced precast concrete. The lintel should be the depth of the inner brickwork and be approximately 700mm long.

Ensure that all dust and rubble is removed from the area. If any wall cladding exists ensure that it is removed and then pack the cavity in the area of the opening with at least 5" (125mm) of Rockwool above and at each side. **It is also necessary to fit a piece of Superlux board or equivalent to seal the top of the cavity to prevent any granular insulation from falling and to prevent heat entering the cavity which may cause smells during operation. This procedure MUST be adhered to else warranty will be void.**— Ensure that the board slopes down towards the outside wall to enable any moisture to run outwards.

Timber Frame Buildings

If the appliance is being installed into a timber framed building the hole through which the flue will pass must have a steel sleeve positioned such that a minimum 25mm air gap exists between the outside diameter of the flue pipe and the metal sleeve – in addition, contact your local building and planning authority (see safety notes on page 5).

Cutting the Hole in Outer Brick Work

Use the template supplied with the appliance to confirm the position.

Ensure that the template is fixed to the wall at the correct height, allowing for the hearth height after its' installation. Mark out the cut-out for the inner brickwork and the flue centre line. Using a core drill is the quickest and easiest method to produce the hole required for the flue in the outer wall. Alternatively a hammer and cold chisel can be used however care should be taken not to damage brickwork surrounding the flue pipe as this will be visible after installation is complete. If damage is caused to outer brickwork this should be made good when completing the installation. Check carefully to ensure that hole is made in the correct position, the hearth height or installation height of the base of the appliance must be known first. See the drawing on page 6. Check also with the terminal position requirements on page 8.

When drilling the hole it is advisable that a pilot hole is drilled first. The hole should be drilled to approximately half the brick depth then complete the hole by drilling from the outside of the building, this will ensure that the entry and exit of the hole are clean and unchipped.

Ensure that the flue hole is drilled horizontally.

The template supplied (see diagram) also shows the correct position for the eye bolts for the wire fixing system.

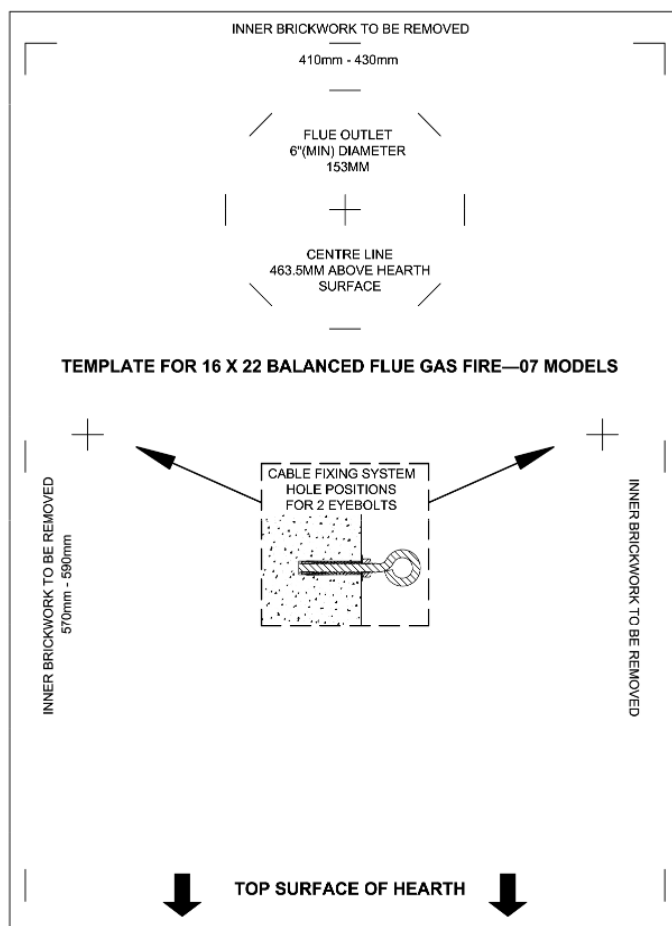

This fire is suitable for fitting to non-combustible fireplace back panels with a temperature rating of at least 150°C. (Check with your fireplace retailer that your back panel and hearth are capable of withstanding the higher temperatures of a balanced flue appliance. Some micro-marble products can contain a high content of resin which can cause smells and discolouration of the backpanel. Hearth Products accept no liability where unsuitable materials have been used.) - If in doubt please contact the supplier of the back panel to check suitability. It is recommended that the back panel be constructed of 3 sections with joints across the upper level of the fireplace section to allow for expansion and contraction. The installation of this appliance into an unsuitable back panel or hearth/mantel material, where a surround component subsequently cracks or causes acrid resin smells, will not be deemed to be a fault of the appliance.

The fire opening must be between the dimensions shown in the figure 4 below. A flat face of a minimum 520mm wide and 620mm high must be provided around this opening to ensure a good seal is formed. Ensure the base of the fireplace opening is flat and level with the hearth surface (if applicable) to ensure a secure and aligned installation of the appliance.

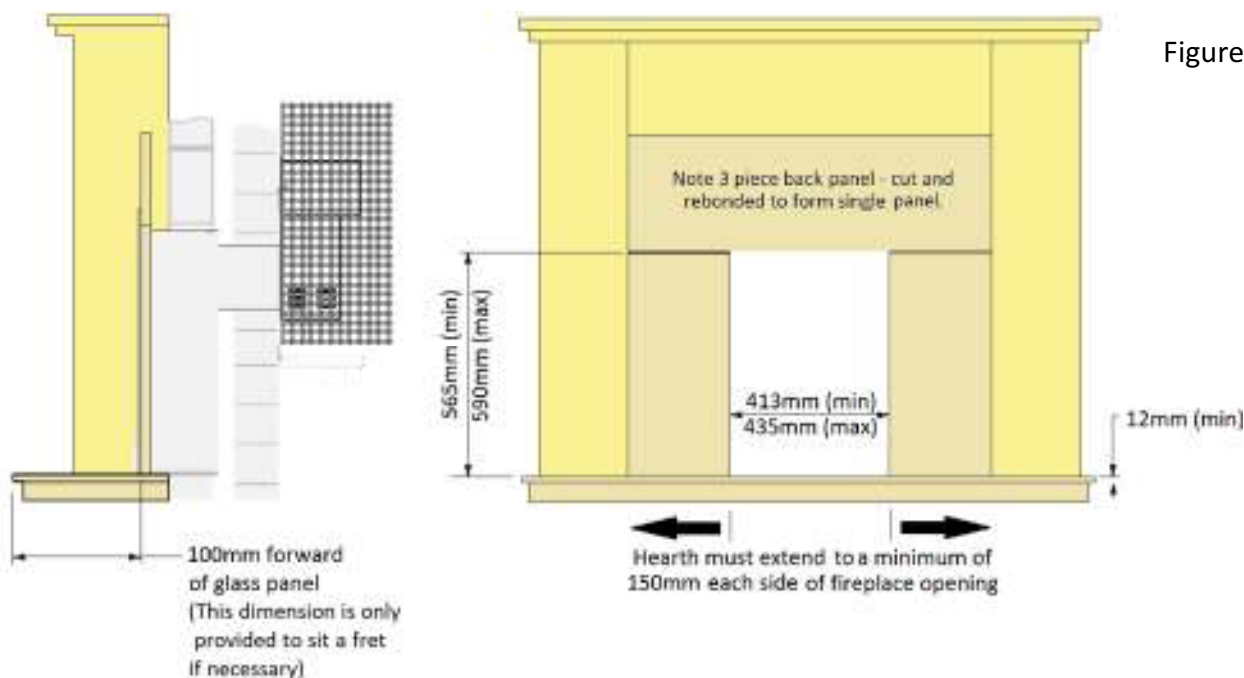

Figure 4

Seal the Gap behind the back panel (Hearth Mounted installations using rebated mantel).

If a gap exists between the rear of the back panel and the wall (due to mantel rebate) this gap should be sealed with bonding or similar to prevent heat from accumulating in this area and affecting mantel shelf temperatures.

Combustible Shelf

This appliance may be fitted below a surround with a combustible shelf providing the following dimensional criteria is met:

There must be a minimum distance of 180mm from the top of the appliance to the underside of the shelf. The shelf must not project more than 150mm from the mounting surface of the appliance into the room. If the shelf projects more than 150mm then the distance between the top of the appliance and the underside of the shelf must be increased accordingly; for every 10mm of projection above 150mm the distance between the fire and shelf must be increased by 5mm

Shelf Protrusion	Min. Distance Between Fire and Shelf
150mm	180mm
160mm	185mm
170mm	190mm
180mm	195mm
190mm	200mm
200mm	205mm

Fireplace Opening when appliance is to be elevated (Hole in the Wall Installation)

This appliance may be installed such that the base of the appliance sits at an elevated position. For this type of installation it is important that the fret to the appliance is either integral with the trim, is fixed to the appliance securely or a small hearth surface is constructed at the base of the opening for the fret to sit upon. If such a hearth is constructed it must be a minimum of 480mm in width and 100mm deep.

A non combustible back panel must be used during this type of installation. Opening sizes are the same as those used for a conventional hearth mounted installation—see Figure 3 on page 9. It is recommended that this back panel provides a border of a minimum of 100mm around the opening.

It is always important to ensure that the appliance is fixed securely to the fireplace opening so that no movement of the ceramics takes place when the appliance is operated. In addition it is imperative that **ONLY** fascia/trim arrangements that are supplied by Hearth Products are deemed suitable to be used with Hearth Products appliances in a 'hole in the wall' installation.

THE INSTALLER MUST INFORM THE USER OF THE FOLLOWING IMPORTANT NOTICES AFTER A HOLE IN THE WALL INSTALLATION HAS BEEN UNDERTAKEN.

1. The user must be made aware to fit a secure fireguard where the room is used by elderly, infirm, infants, young children or pets.
2. The customer should be advised to fit a hearth panel or a physical barrier in accordance with BS5871-2. Should this advice not be followed the customer should be advised to give due to consideration to the safety of the occupants in the room where the appliance is to be installed. The customer should be informed that the glass panel on this appliance gets extremely hot when in use.
3. The user must be made aware to keep the area immediately in front of the appliance clear of combustibles items. This does not include the floor covering however such covering should be fixed.
4. The user must ensure that the ceramic fuel bed is maintained in the correct condition of installation, especially after cleaning. If the fuel bed is removed for cleaning or maintenance the ceramics should be checked for secure placing and tested for movement during appliance operation.
5. The user must ensure that other occupants of the room where the appliance is installed are notified to not get unnecessarily close to the appliance when in use or to position any furniture or appliances too close to the fire.

Preparing the Gas Supply for the Appliance

A gas soundness test should be performed to ensure that the existing pipe work in the property is sound.

The gas supply can be prepared for a concealed fitting from the rear. In all installation conditions the gas connection should be provided using 8mm (O/D) copper tubing. If the concealed installation method is chosen, there are three optional entry points at the rear/side of the appliance. The relevant 'knock-out' entry point should be removed to allow the gas supply to enter the appliance. **No soldered joints** should be used within the firebox of the appliance.

The connection to the appliance will be made using the restrictor isolation valve supplied with the appliance. This restrictor elbow is supplied loose and should be fitted as per the label on the instruction packet.

Ensure a gas soundness test has been performed to ensure that the existing pipe work in the property is sound.

If any part of the gas pipe will be situated in the cavity it **MUST** be sleeved in accordance with BS6891. flexible sleeving is permitted.

Fixing the Appliance.

If the appliance is being installed with a spacer kit, this should be attached to the appliance using the screws included. The fire retardant foam strip which is supplied with the appliance should be affixed to the rear face of the spacer. Do not use any permanent sealing substance as this will invalidate warranty.

With the **UNCUT FLUES FITTED** to the appliance, drill the 3 holes as shown in the OUTER flue and fix with the 3 screws provided. Next place the fire into its installation position, temporarily, while the flue lengths are confirmed.

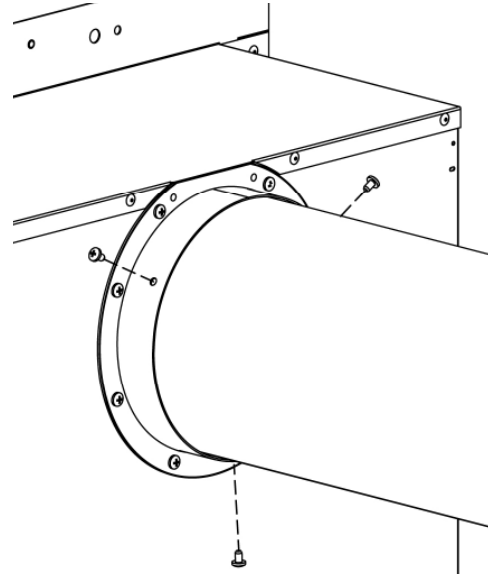

Next, Remove the six screws to release the wall plate from the terminal.

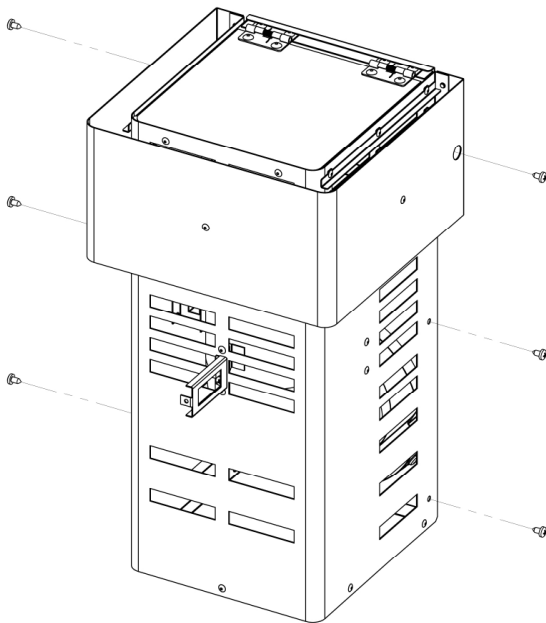

Now **temporarily** secure the wall plate using the screws and plug supplied.

The flues need to protrude through the wall plate by 12mm to ensure it can be fastened by the 3 lugs on the wall plate.

Mark these 3 hole positions which need to be drilled at 3mm dia.

Make a mark on the outer flue at a position 12mm past the wall plate surface.

NOTE: THIS MARK WILL SHOW HOW MUCH THE FLUE IS TO BE SHORTENED.

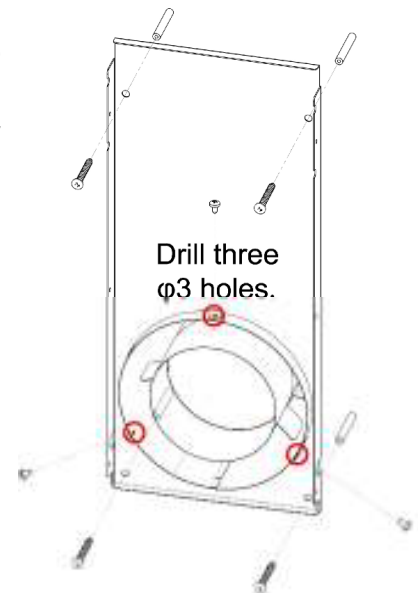

SEE PAGE 14 FOR MORE DETAIL.

Next, unscrew the wall plate from the wall.

Remove the two flue sections from the appliance.

Remove the appliance from its installed position.

The OUTER flue can be cut at the line marked in the previous step.

Measure the amount of flue removed from OUTER flue.

Now cut this same amount from the INNER flue—from the end which is inserted in the fire.

DO NOT REMOVE FROM THE END WITH THE 3 LOCATING FEATURES. (See page 14)

Ensure that the flues are cut correctly. If any flue length is cut incorrectly the installation cannot proceed. Replacement flue pipes will have to be purchased from the manufacturer.

Now refit the flues to the appliance—use the 3 screws to secure the OUTER flue to the flange of the appliance.

Use the metal tape to seal the OUTER flue to the fire.

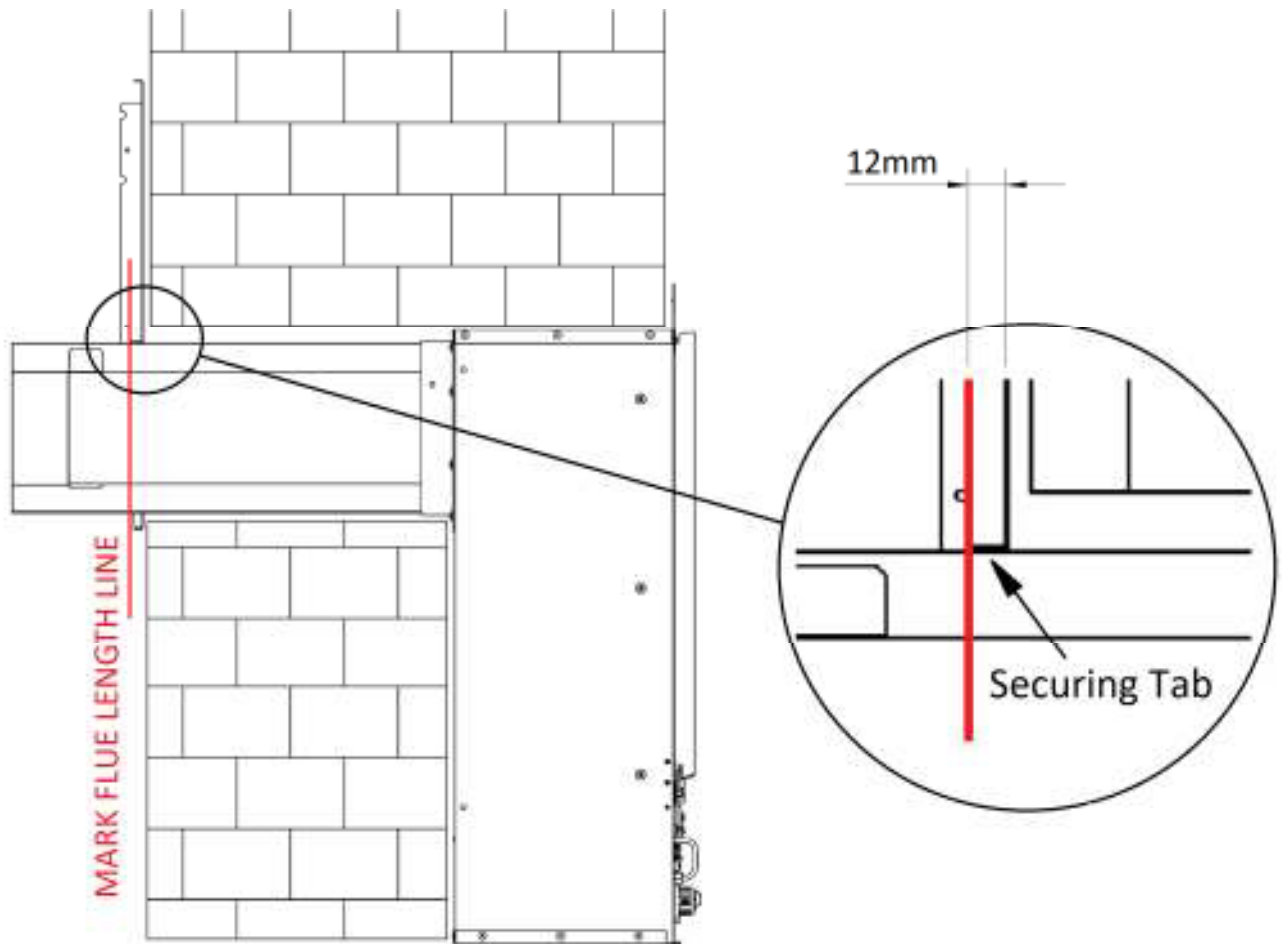

The rear face of the wall plate should be sealed with proprietary sealing compound or mortar.

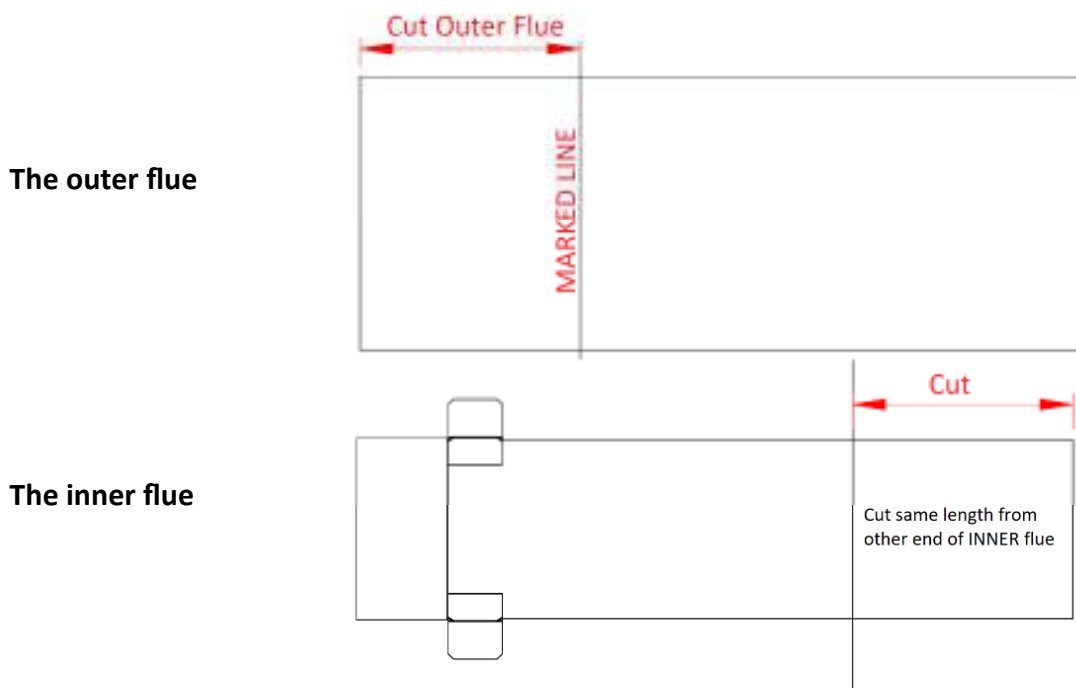

Cable Fixing System (Supplied as standard)

This appliance is best installed with the cable fitting system which is supplied in the standard fitting pack. The fitting system comprises two (2) eyebolts and two (2) fixing cables, the appliance is secured with the clamping nipples on each side.

Simply drill and fit the eyebolts in the positions shown on the template. This diagram shows the details of the holes required to secure the eyelets.

This installation DOES NOT require the burner tray to be removed from the firebox.

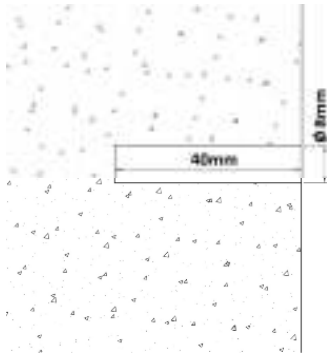

Drill a hole 8mm dia. by 40mm deep. Ensure all the debris is removed from the hole. Use a wrench to twist the nut tightly until the anchor is solid and reliable.

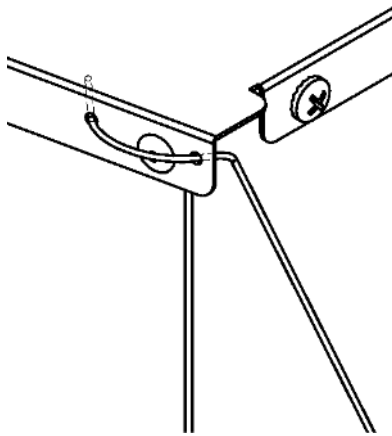
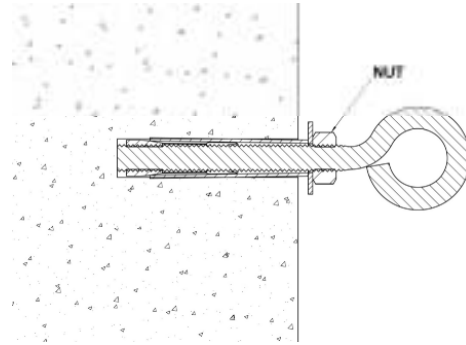

Thread each wire through the holes in the fire box as shown in this diagram.

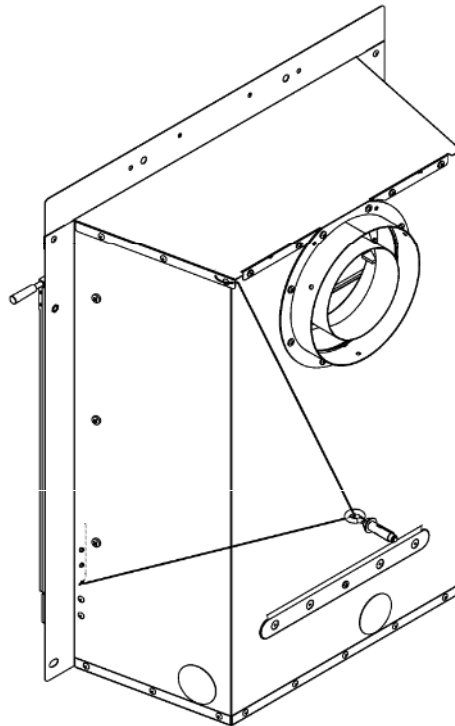

Then pass the other side of wire through the wall eyelet and finally through the lower hole at the front of the appliance.

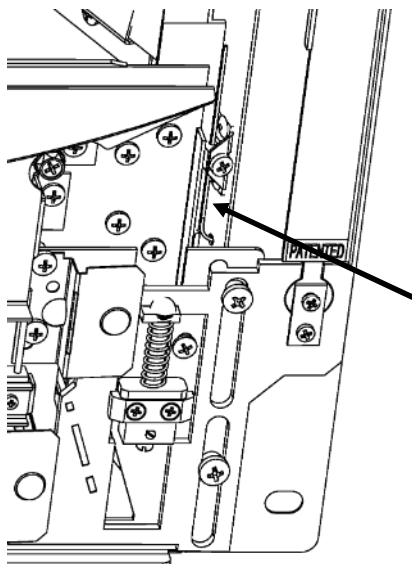

Thread the wire through the hole below the nipple as shown. Pull the wire taut to secure the appliance against the back panel. Finally tighten the small screw on the nipple.

FITTING THE TERMINAL & TERMINAL GUARD

ONLY THE TERMINAL AND TERMINAL GUARD SUPPLIED WITH THIS PRODUCT SHOULD BE FITTED. THIS TERMINAL GUARD ALLOWS CLEARANCE FOR BLAST FLAP CLEARANCE.

Fix the appliance into its installed position using the wire fixing cables. Pull taut to ensure the fire is in the correct position.

From the outside carefully insert the inner flue, the flue guides should be towards the outside wall, to keep the two flues concentric before they enter the terminal.

Use mortar to tidy any gaps between the outer flue and the wall prior to re-fitting the wall plate.

Fit the guard locating bracket to the flue terminal.

This component is very important as it ensures clearance above the terminal for blast relief flap to open fully.

Secure the outer flue with the three lugs on the wall plate using the 3 screws provided.

Secure the terminal to the wall plate, ensuring the inner elbow locates firmly into the inner flue.

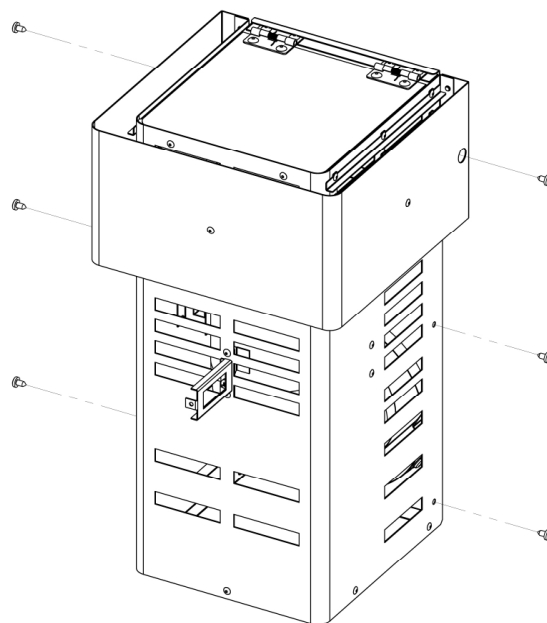
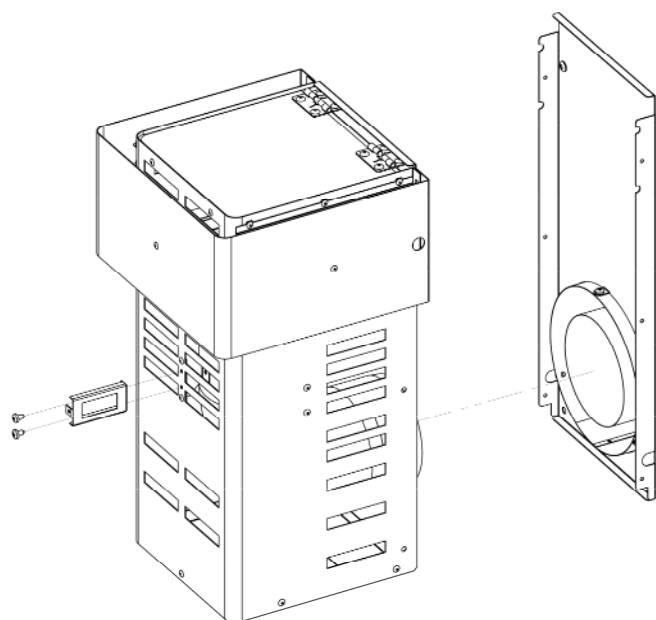

Connecting the Appliance to the Gas Supply

In all installation conditions the gas connection should be provided using 8mm (O/D) copper tubing. The relevant 'knock-out' entry point should be removed to allow the gas supply to enter the appliance. **No soldered joints** should be used with the firebox of the appliance.

Ensure a gas soundness test has been performed to ensure that the existing pipe work in the property is sound.

The connection to the appliance will be made using the 8mm restrictor isolation valve supplied with the appliance. This restrictor elbow is supplied loose and should be fitted as per the label on the instruction packet.

Using the diagram below, fold the terminal guard, aligning the screw fixing holes in each corner to create the correct shape.

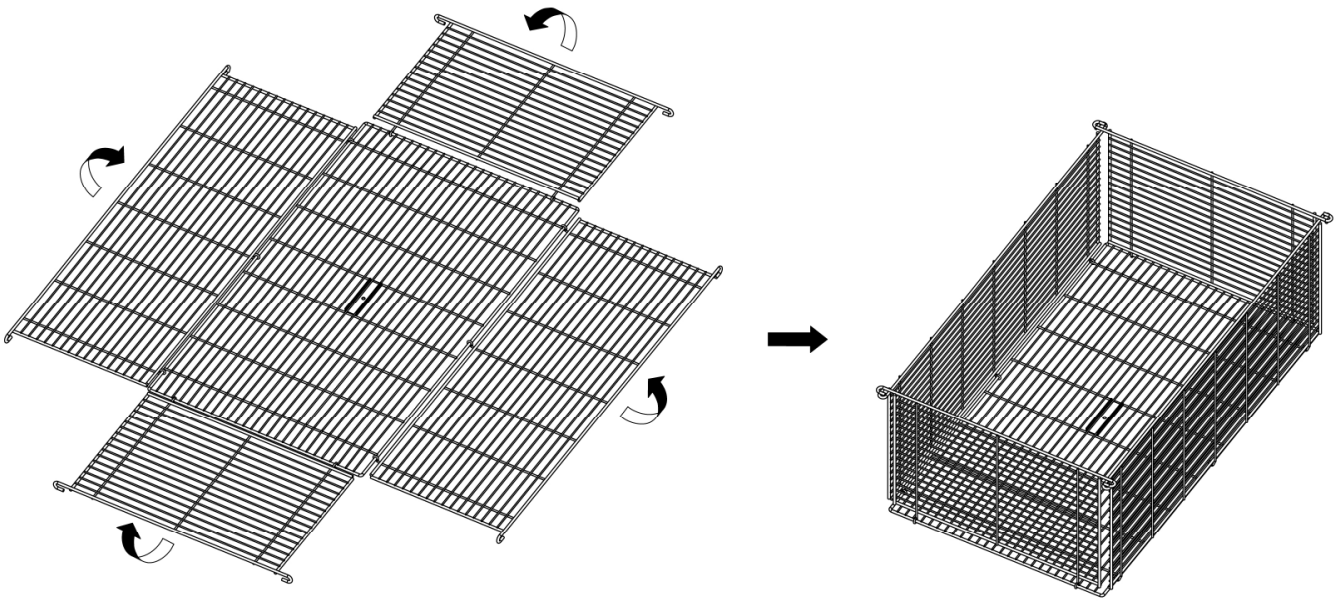

Screw the guard to the terminal locating bracket (fitted earlier).

This must be fitted correctly to ensure that the correct clearance is maintained above the terminal for the blast relief flap to open fully.

Now fix the guard to the wall using the screws and plugs provided.

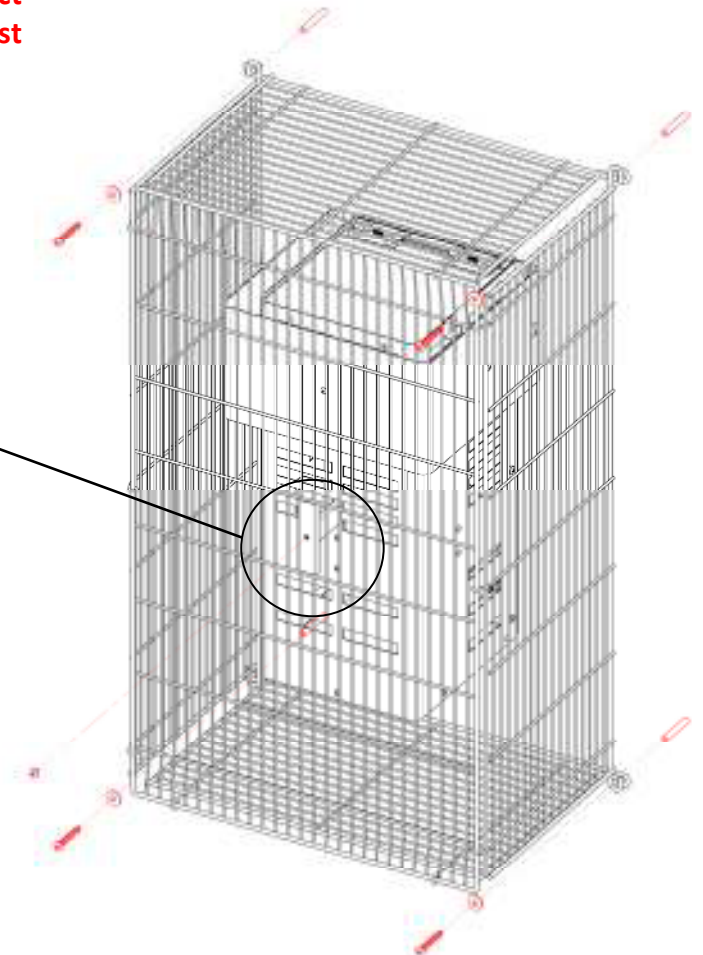
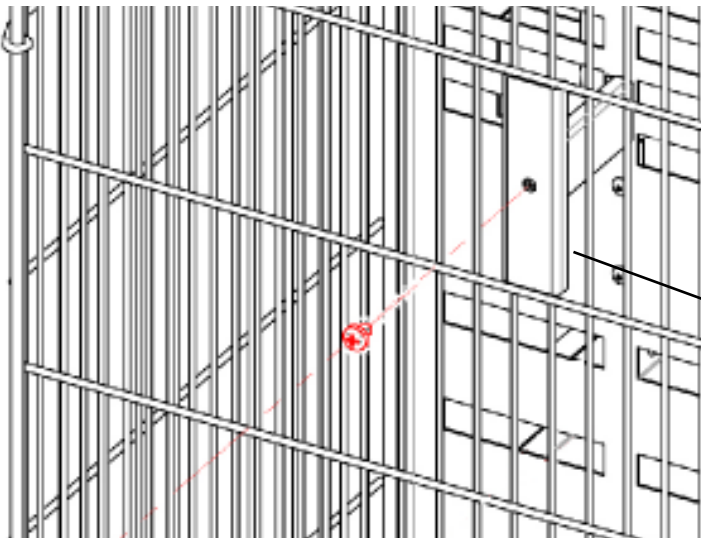

Appliance Data

Gas Type	Natural Gas
Inlet Pressure	20mbar \pm 1mbar
Gas Connection	8mm pipe
Injector	1.62
Pilot Body (No Thermocouple)	P-XX1318
Thermocouple (Manual control)	P-XX13181
Thermocouple c/w Microswitch (Slide control)	P-XX13182
Input High Rate (Gross)	4.2kW (0.4m ³ /hr)
Input Low Rate Manual Control (Gross)	2.9kW (0.27m ³ /hr)
Input Low Rate Slide Control (Gross)	2.5kW (0.21m ³ /hr)
Battery Type (Electronic Igniter)	AA
Wall Depth (Min)*	290 mm
Wall Depth (Max)*	570 mm
Fire Depth	191mm
NOx Class	Class 5
Efficiency Class	Class 1

* The wall depth is calculated as the distance from the front face of the back panel surface to the outside face of the exterior wall.

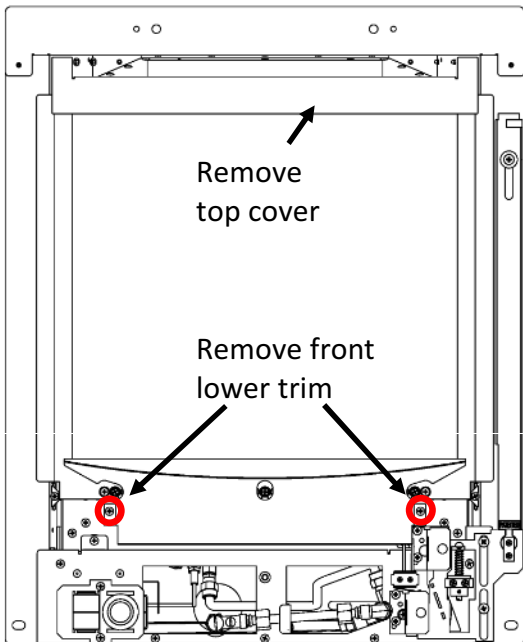

Removal of the front glass panel.

The glass panel is held in place with 6 hexagon headed screws. This panel is concealed behind the top cover strip which is held in place by two magnets. The two magnets are fitted to the top glass clamp as shown in this diagram.

First remove the two screws holding the front lower trim panel in place.

Now carefully remove the top 3 fixing hexagon headed screws and loosen the lower three hexagon headed screws whilst supporting the glass panel. Now lift the glass from the appliance.

Now the ceramics can be installed, rearranged correctly or removed for service. Correct installation of ceramics is details on pages 20 - 22.

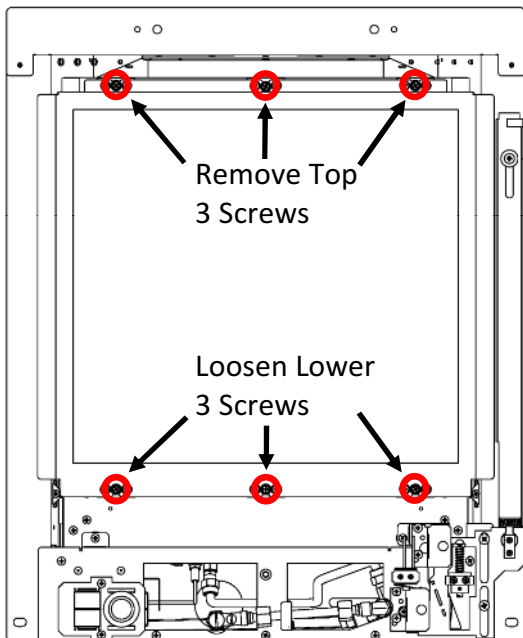

Installation of the front glass panel.

Before replacing the glass ensure that the seal around the top and two sides of the firebox is in good condition and is securely affixed to the appliance. If the seal is damaged or loose then it should be replaced / reattached before the glass is replaced. This seal is important and if damaged, the appliance should not be operated.

The glass panel should be undamaged. If the glass panel is broken or cracked it should not be used. Contact the manufacturer for a suitable replacement before continuing.

Replace the glass panel into position by locating the bottom edge around the three screw locations.

Rotate the glass panel back into position and hold whilst the top 3 screws are inserted.

Ensuring the two magnets are in the correct position (see diagram) then the top cover can be placed into position. This component is purely decorative and is used to conceal the fixing screws.

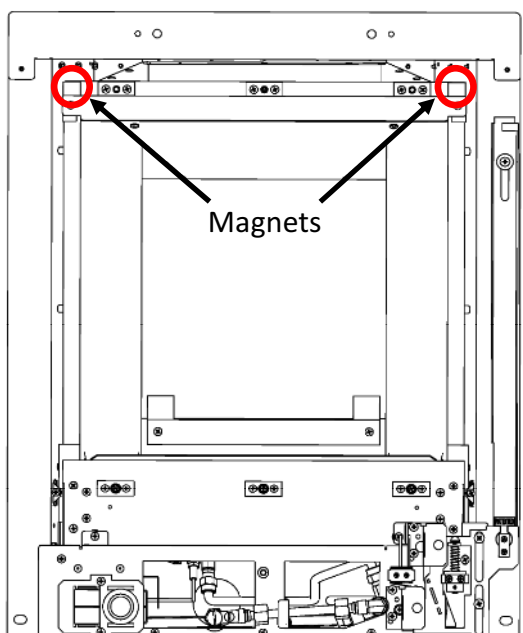

Note: Should the threads in the retaining bosses become damaged, they can be replaced by removing the two screws either side of the boss. Contact the manufacturer for further details and supply.

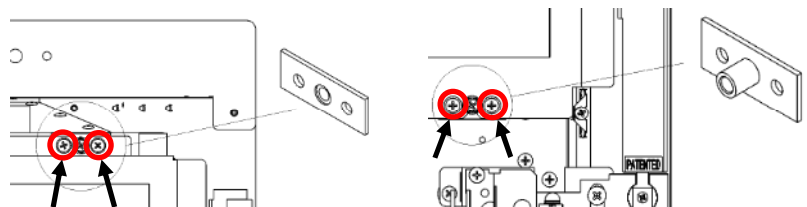

COAL SETUP

The following instructions detail how the ceramic fuel bed and loose components are to be installed onto the appliance. Great care should be taken when handling these ceramic parts as they are fragile and can easily be broken. Do not force any component into position, if it does not fit easily then you are not fitting the part correctly. These instructions can also be followed to remove or reinstall the fuel bed after cleaning. This is a procedure that can be undertaken by the customer as required and the frequency will be depend upon use.

See page 19 for glass door removal and installation.

These components will have been installed by your gas engineer at the point of installation, however it is permitted for the end user to remove clean and replace these components as necessary. The following installation instructions must be adhered to at all times.

The following diagram is for identification purposes. It is imperative that the coal are placed in the correct position for safety and also to ensure that you obtain optimal performance from your appliance.

FUELBED

Fit the front fuel bed into the appliance as shown in the picture below.

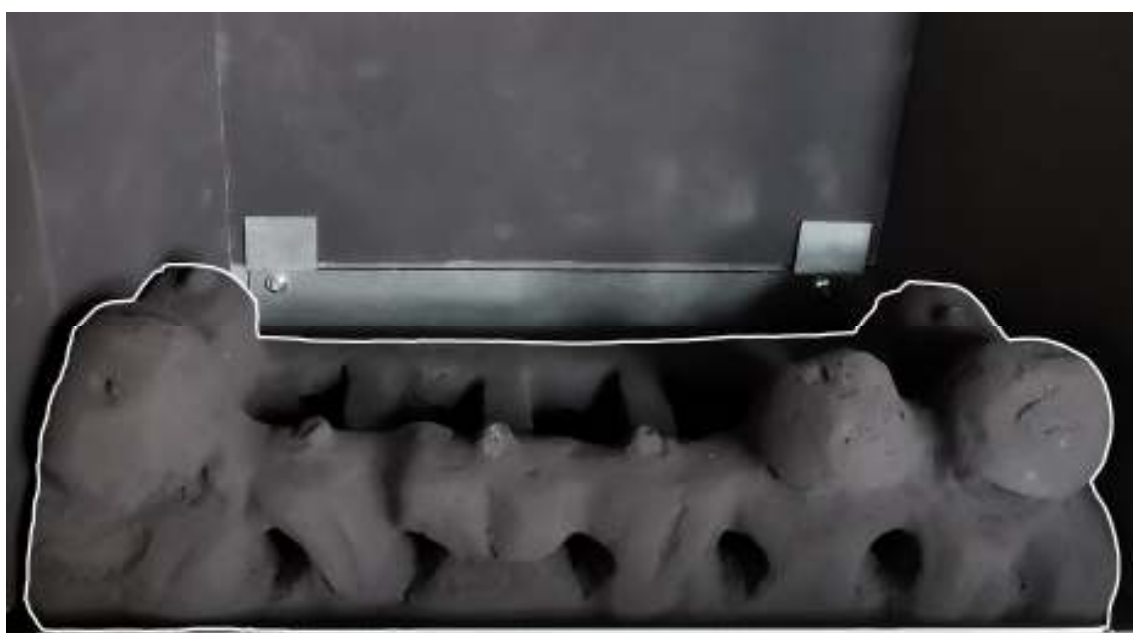

Fit the rear fuel bed into the appliance as shown in the picture below.

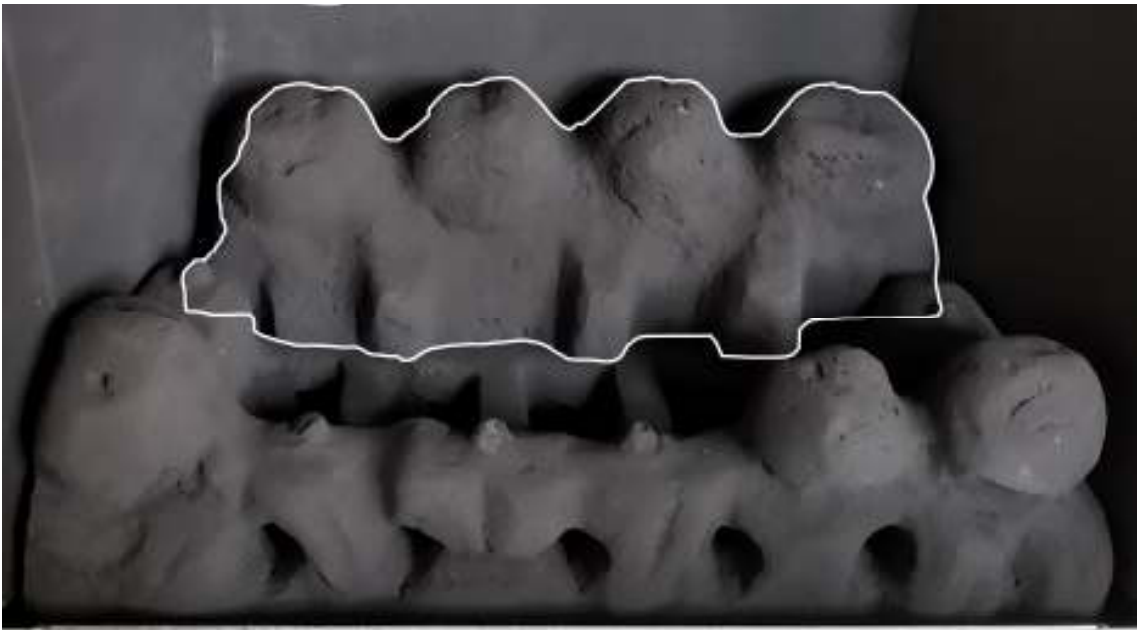

Fit the coal A into the appliance as shown in the picture below.

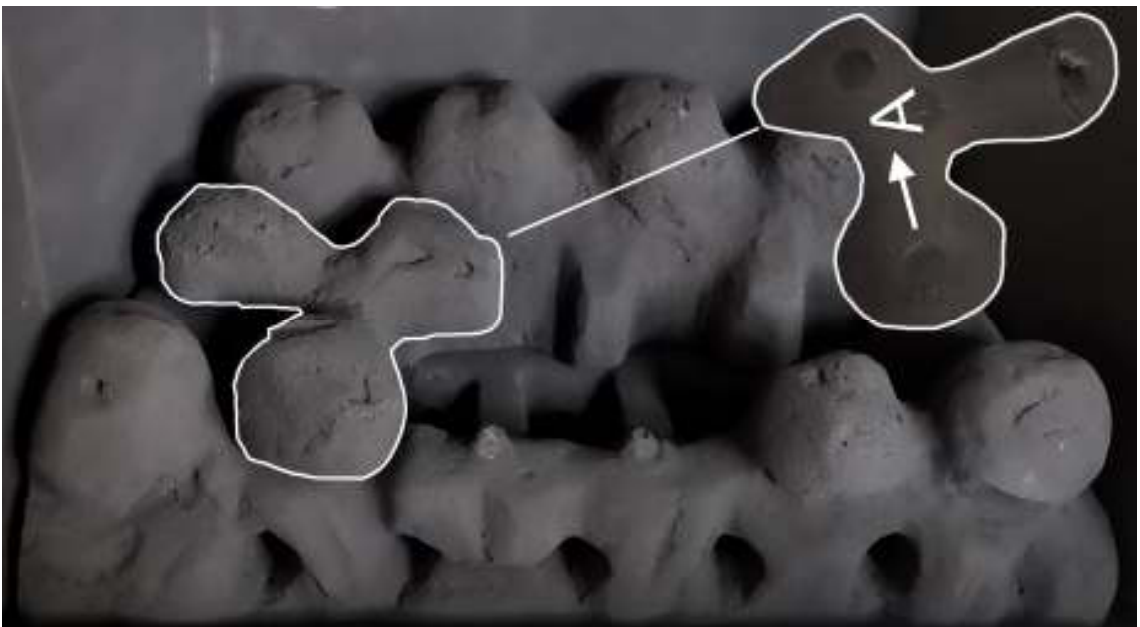

Fit the coal B into the appliance as shown in the picture below.

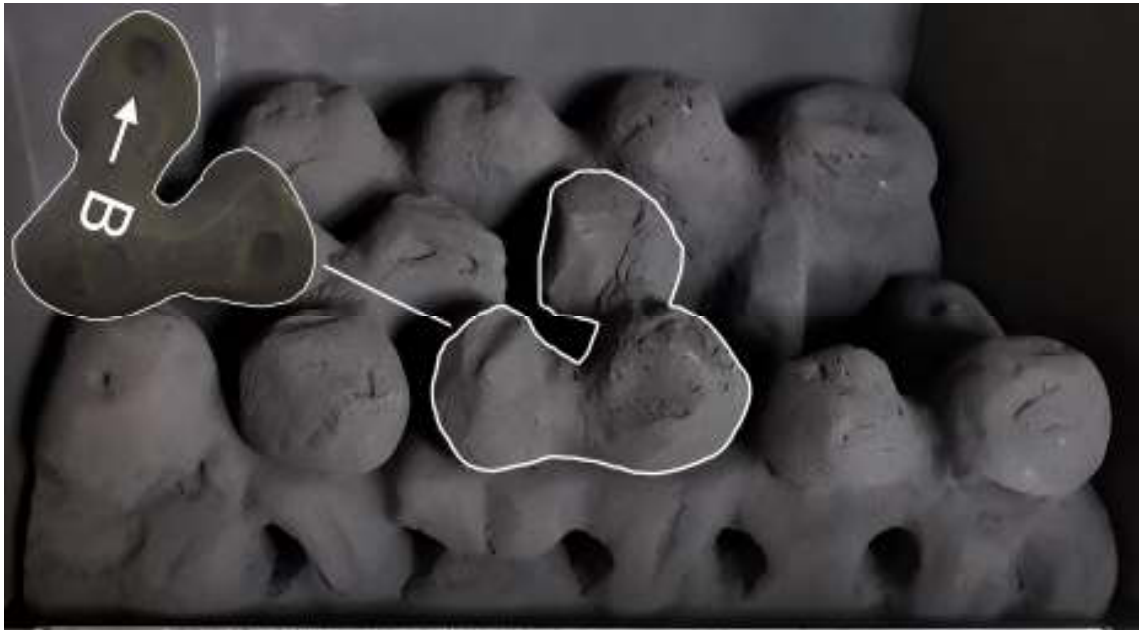

Fit the coal C into the appliance as shown in the picture below.

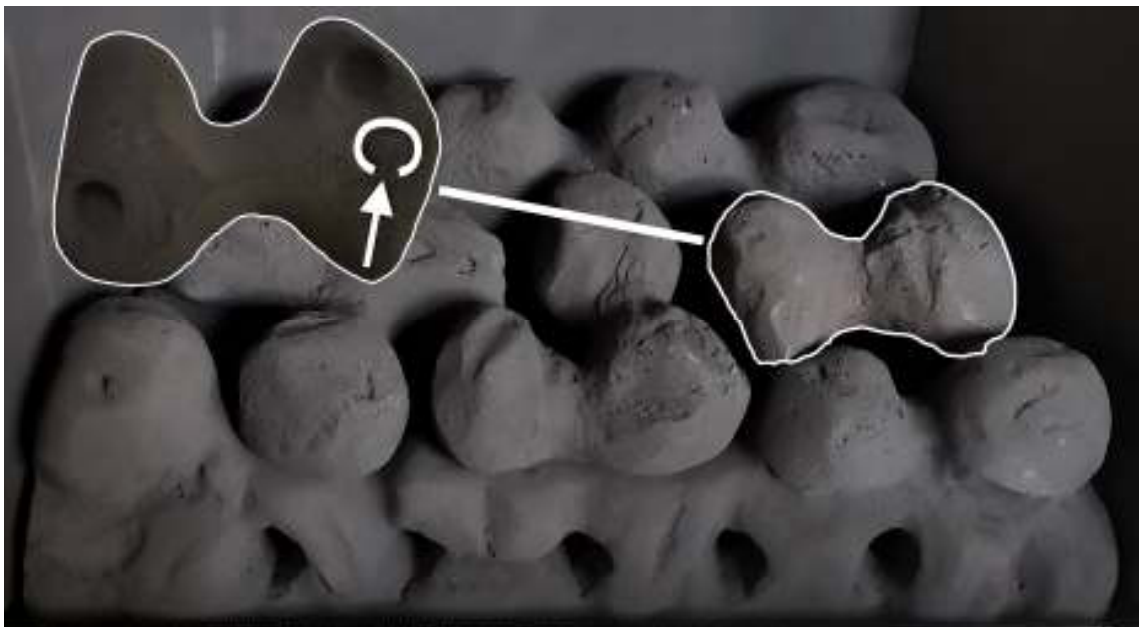

Lighting

2.1.1 Rotating the control knob to the ignition symbol and push in. Push the igniter button situated at the bottom left side of the appliance, the pilot should light.



If the pilot light does not light, the knob should be rotated back to the OFF position and wait for 3 minutes before reattempting. If the pilot does not light after 3 attempts, Check the battery—see below and also check that the ember wire is not sitting near the pilot causing a short circuit. If the battery is new and the pilot still fails to light, contact a gas safe engineer.



Once the pilot is lit, hold the valve pushed in for up to 10 seconds then release. The pilot should stay lit and then rotating the knob anti-clockwise to the LOW symbol, main burners will now light. The appliance is now running at the LOW setting.



Rotating the knob anti-clockwise to increase flame. The appliance is now running at the HIGH setting.



To turn the fire off, rotating the knob to the OFF symbol.



Should the spark generator fail to provide a spark at the electrode it may be that a small amount of soot or ember wire has fallen from the fuel bed onto the pilot assembly, causing a short circuit. If this is the case, ensuring the appliance is off and cold, this area can be cleared after removing the glass panel - See page 19 for details on glass removal to access this area.

Alternatively check the battery is in good condition. This diagram shows the location of the igniter. Unscrew the cap to access the battery compartment. When replacing the battery check it is inserted correctly.

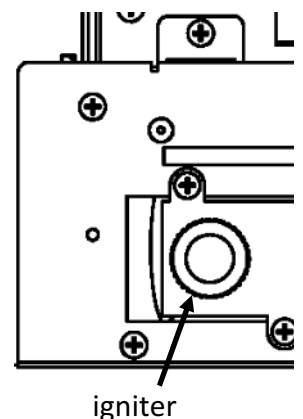

If the appliance is extinguished or goes out, wait for 3 minutes before attempting to relight the appliance.

The flames will appear blue until the appliance reaches temperature. This can take between 10 and 20 minutes. The customer should be advised of this fact.

Lighting

2.1.2 Slide the control knob down to the ignition symbol. After a few seconds the pilot light should light.



If the pilot light does not light, release the control knob and wait for 3 minutes before reattempting. If the pilot does not light after 3 attempts,



Check the battery—see below and also check that the ember wire is not sitting near the pilot causing a short circuit.

If the battery is new and the pilot still fails to light, contact a gas safe engineer.

Once the pilot is lit, keep the lever pushed down for up to 10 seconds then release. The pilot should stay lit and main burner will now light.



The appliance is now running at the LOW setting.

Slide the knob slowly upwards to increase flame.



The appliance is now running at the HIGH setting.

To turn the fire off, slide the lever all the way to the top to the OFF symbol.



Should the spark generator fail to provide a spark at the electrode it may be that a small amount of soot or ember wire has fallen from the fuel bed onto the pilot assembly, causing a short circuit. If this is the case, ensuring the appliance is off and cold, this area can be cleared after removing the glass panel - See page 19 for details on glass removal to access this area.

Alternatively check the battery is in good condition. This diagram shows the location of the igniter. Unscrew the cap to access the battery compartment. When replacing the battery check it is inserted correctly.

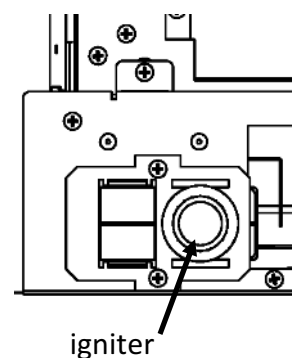

If the appliance is extinguished or goes out, wait for 3 minutes before attempting to relight the appliance.

The flames will appear blue until the appliance reaches temperature. This can take between 10 and 20 minutes. The customer should be advised of this fact.

Completing the Installation of the Appliance

Remove the protective covering (if applicable) from the face of the decorative trim. Fit the trim to the appliance with the magnets provided. One magnet should be placed in each corner of the trim at the top of the appliance and on each side about 120mm from the base of the appliance. In the case of slide control appliances care should be taken that the magnet does not come into contact with any moving parts of the lever mechanism. This advice should also be passed onto the consumer to ensure that they are aware of magnet positioning. A service call due to incorrect placement of magnets which cause difficulty in lighting the appliance will result in a callout charge being made.

Fix the front bars to the trim according to the instructions supplied with the appliance or position the fret in front of the fire, ensuring that the ashpan cover is sitting correctly and allows access to the controls (for manual control models).

THE INSTALLER MUST INFORM THE CUSTOMER OF THE FOLLOWING TO COMPLETE THE INSTALLATION

Demonstrate the lighting of the appliance and the controls to control the heat settings. Demonstrate how to extinguish the fire.

Demonstrate the removal of the trim and fret and how to reinstall correctly.

Discuss the removal and reinstallation of the glass and the ceramics. Explain how they should be cleaned and make the customer aware of the health and safety warning detailed later in these instructions.

Explain to the customer that the ceramics are fragile and must be treated with great care, explain that the ceramics are not covered by the warranty because of their fragility. Also explain that small hairline cracks will appear in the surface of the ceramics due to heat expansion and contraction—this is perfectly normal.

During the first several hours of use an odour will be experienced—this is normal and is the starch used in the manufacturing of the ceramic fuel bed. This odour is non toxic and will eventually disappear with use.

Advise that no rubbish should be thrown onto the appliance and that the appliance should be cleaned regularly.

A vacuum cleaner can be used but it is important that the appliance is turned off and allowed to cool before undertaking this procedure. See the separate section regarding cleaning the ceramics.

Advise the customer that the appliance should be serviced annually by a gas safe engineer to ensure the safety and integrity of the appliance.

Advise the customer that the appliance has a hot glass surface and therefore it is essential that a suitable fireguard be used for the protection of the elderly, infirm and young children. This fireguard should conform to BS8423 : 2002 (Fireguards or use with Gas Heating Appliances).

These instructions **must** be handed over to the customer once installation is complete.

HEALTH AND SAFETY NOTICE

This appliance uses fuel effect pieces manufactured from Refractory Ceramic Fibres (RCF). Care must be taken to avoid excessive exposure to these materials as they may cause irritation to the eyes, skin, nose and throat. When Handling avoid inhaling and contact with skin and eyes. It is recommended that disposable gloves are worn in addition to a facemask and eye protection. After handling wash hands thoroughly and any other exposed parts which may have come in to contact with the material.

If a vacuum cleaner is used to clean the fuel bed or areas around the appliance there fragments of the material may have fallen it is recommended that it be of the type fitted with a HEPA filter.

Care should be taken when disposing of RCF materials. It is important to keep any dust to a minimum so it is recommended that the fuel effect components are placed into a heavy duty plastic bag. The bag should be clearly labelled **RCF WASTE**. These materials are not classified as hazardous waste and should be disposed of at a site approved for the disposal of industrial waste.

Cleaning the Appliance

Ensure the fire is turned off and has been allowed to cool for a period of at least one hour.

Metal Parts

Metal parts can be cleaned with a slightly damp cloth, once wiped, any moisture should be removed with a soft clean cloth. Do not use any abrasive cloths or cleaning solutions, these may scratch the surface.

Trim and Front Bars

There are a variety of trim and fret options which may have been supplied with your appliance and these are normally a plated material on a steel substrate. It is important that no abrasive cleaners or chemical agents are used in the cleaning of these components. It is recommended that all these surfaces are cleaned with a clean damp (not wet) cloth.

Fuel Bed

The fuel effect components supplied with this product are extremely fragile and must be handled with great care. The ceramics in this appliance are not covered by the warranty due to their fragility. This includes the RCF fibre boards in the fire box. These components will break or chip if not handled with the greatest of care.

Cleaning of these components should only be undertaken once the appliance is switched off and has been allowed to cool for a minimum period of one hour. The glass should be removed (see page 19 for full details). The ceramic components should be lifted carefully piece by piece from the appliance and placed onto a dust sheet or similar. They can be brushed gently with a soft brush to remove any dust or deposits. If you intend to use a vacuum cleaner then this should only be done once the loose deposits of soot etc have been removed. Ensure that the moulded components are structurally sound and no significant part of the moulding has broken away. If any component has broken then it should be replaced before using the appliance. Only the correct replacement part as supplied by the manufacturer shall be used in this appliance. Do not add any additional components to the fuel bed layout. It is important to note that small hairline cracks will appear in the surface of the ceramics due to heat expansion and contraction—this is perfectly normal.

Ensure that the ceramics are replaced correctly, as per the instructions in this manual.

Running In

When this appliance is first used it is important to note that you will experience some fumes and smells in the room of operation. Any fumes emitted during the first few minutes of use can be quite pungent and it is advised that a window is opened until this subsides. Smells associated with paints, oils and starch from ceramic components may last several hours but will rapidly diminish over the first few uses of the appliance.

It is advisable that the appliance is always run on high for a period of at least 20 minutes before turning to low, to ensure optimal flue performance and to reduce the possibility of sooting.

It should be noted that as with all flame effect gas appliances, some sooting can be evident and can be cleaned away—see cleaning instructions on previous pages.

Trouble Shooting

The following table should be used to identify any problems experienced with the operating or running of your appliance prior to contacting the manufacturer or retailer regarding service.

THE FIRE WILL NOT LIGHT

Can you hear a continuous clicking during the ignition process?	YES ↓	NO Check Battery
Does the pilot light?	YES ↓	NO Check and remove soot or <i>ember wire</i> near the pilot
Does the pilot go out when the lever/control knob is released?	YES →	Try again, but before releasing the lever give a firm push to the left before releasing the lever.

THE FIRE GOES OUT

Does the fire light and run ok then subsequently turns off automatically	YES →	The thermocouple may be reaching the end of its life and should be replaced if this problem persists.
--	-------	---

VISUAL PROBLEMS

Does the flame picture look wrong?	YES →	Check ceramic fuel bed placement as per the user instructions see pages 20-22
Does the glass have grey water marks on inside surface	YES →	The glass will require infrequent cleaning dependant on use. See page 6 to open door.
Do you see marks or discolouration above the centre of the appliance?	YES	The gas fire is spilling, turn the unit off and call for your gas safe engineer.

Warranty



The Wildfire 5 year limited guarantee is managed directly by Hearth Products Ltd. With our experienced Gas Safe engineers and through our extensive network of service centres throughout the UK we will ensure your appliance receives the right care should anything fail prematurely. Choose Wildfire for style, performance, reliability, value and peace of mind. Note that it is a condition of the extended

Servicing

Servicing the Appliance.

The following procedures can and should **only** be performed by a **Gas Safe registered installer**.

This appliance should be serviced annually by a **Gas Safe registered installer**.



Isolate the appliance using the restrictor elbow and remove the 8mm nut from the restrictor as detailed below.

ALL SERVICE WORK WILL REQUIRE THE REMOVAL OF THE GLASS PANEL AND THE CERAMICS—SEE PAGE 19-22.

Removal/Replacement of the slide Valve

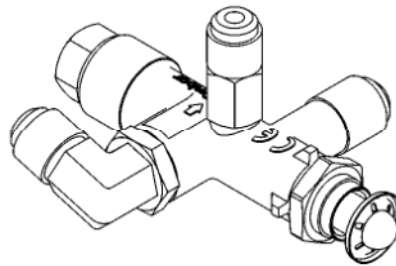

Remove the 8 screws shown in this diagram.

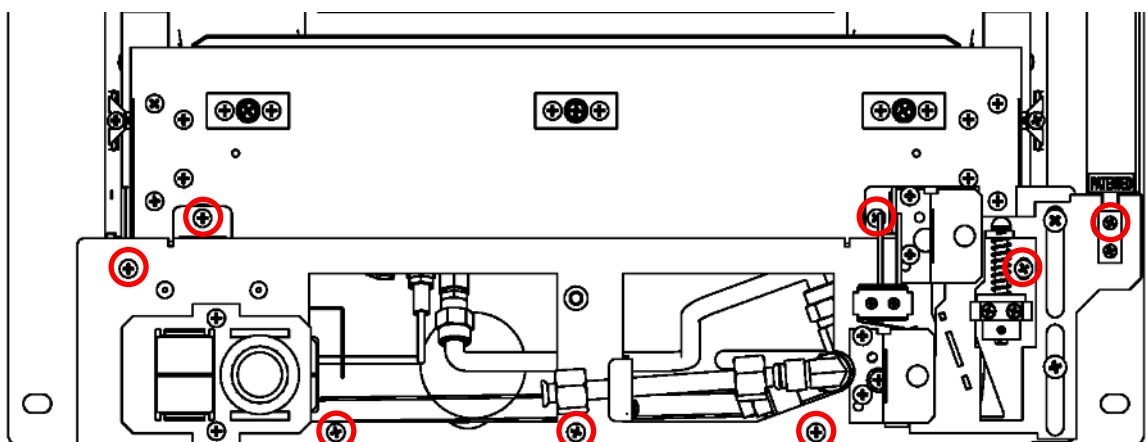

Removal/Replacement of the slide Valve—continued.

Gently ease the front tray forward, the gas pipes are flexible but take care when moving to ensure the pipes move uniformly as it is removed.

It should only be pulled forward to gain access to the main gas outlet port on the rear face of the valve.

Removal of the pilot tube and the main tube, then remove the thermocouple from the back of the valve.

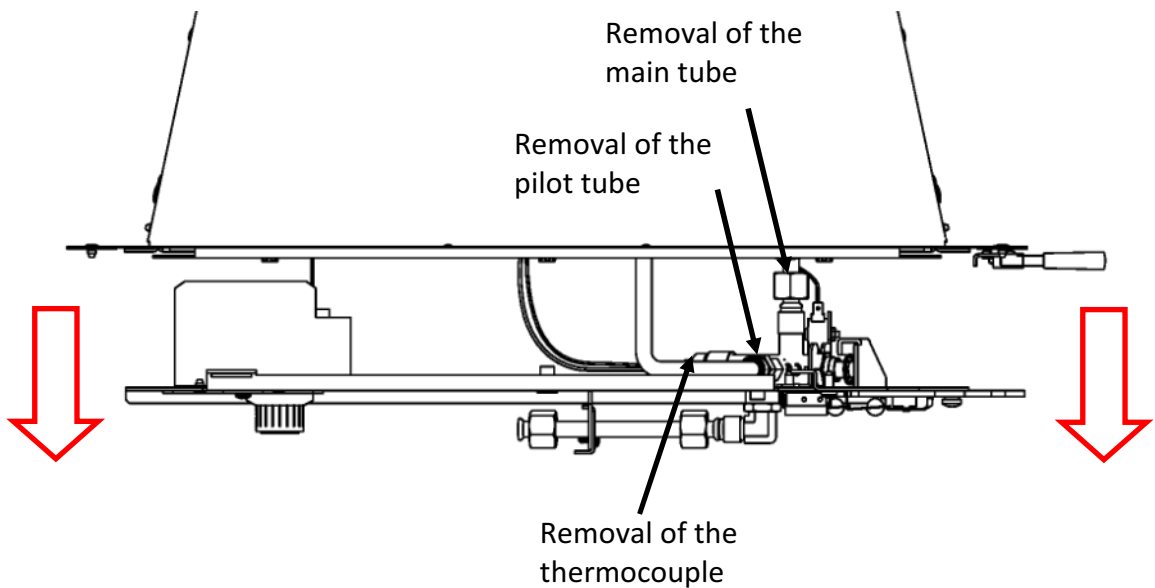

Removal of the gas inlet tube from the inlet of the gas valve.

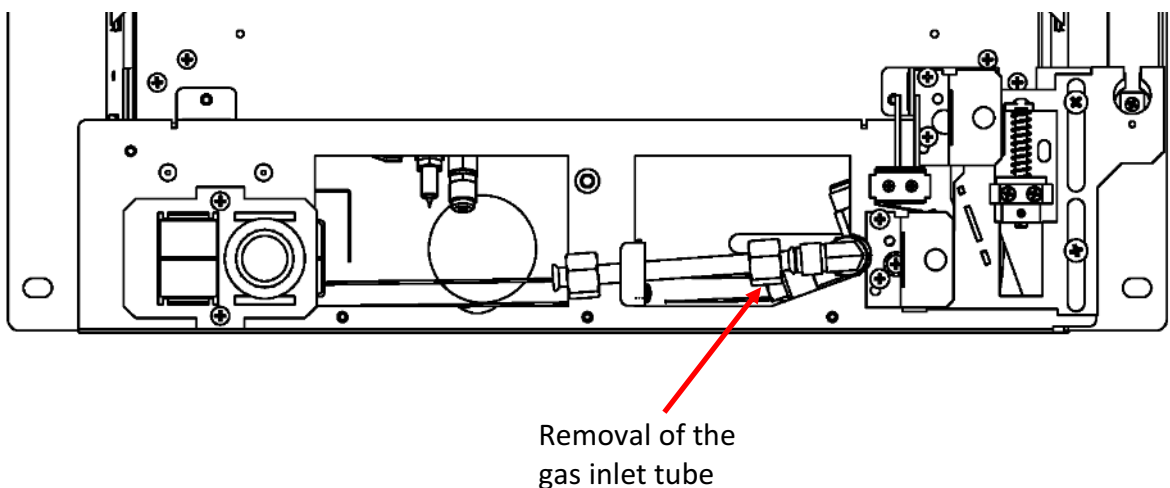

Removal/Replacement of the slide Valve—continued.

Remove the three screws from the stainless runner guide to release the valve.

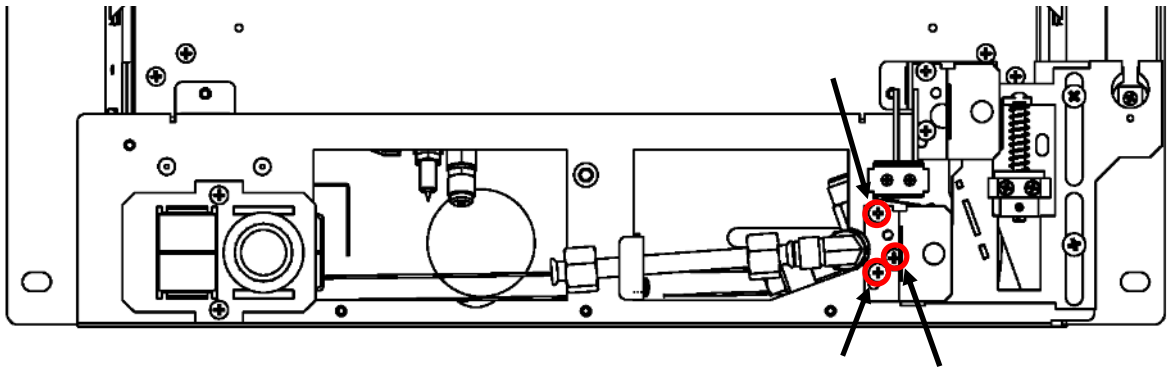

Removal of the lock nut at the top of the valve.

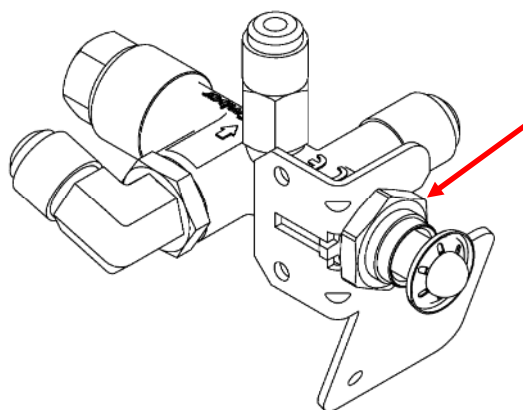

Removal/Replacement of the manual Valve

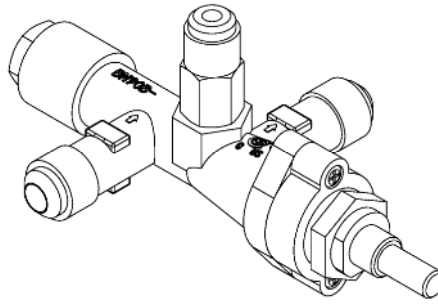

Remove the 7 screws shown in this diagram.

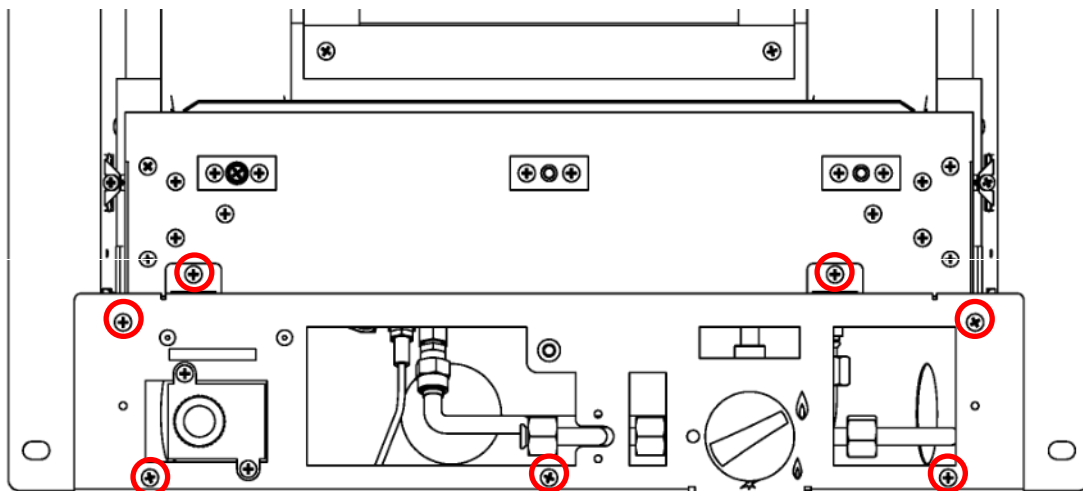

Gently ease the front tray forward, the gas pipes are flexible but take care when moving to ensure the pipes move uniformly as it is removed.

It should only be pulled forward to gain access to the main gas outlet port on the rear face of the valve.

Removal of the gas inlet tube, the pilot tube and the main tube, then remove the thermocouple from the back of the valve.

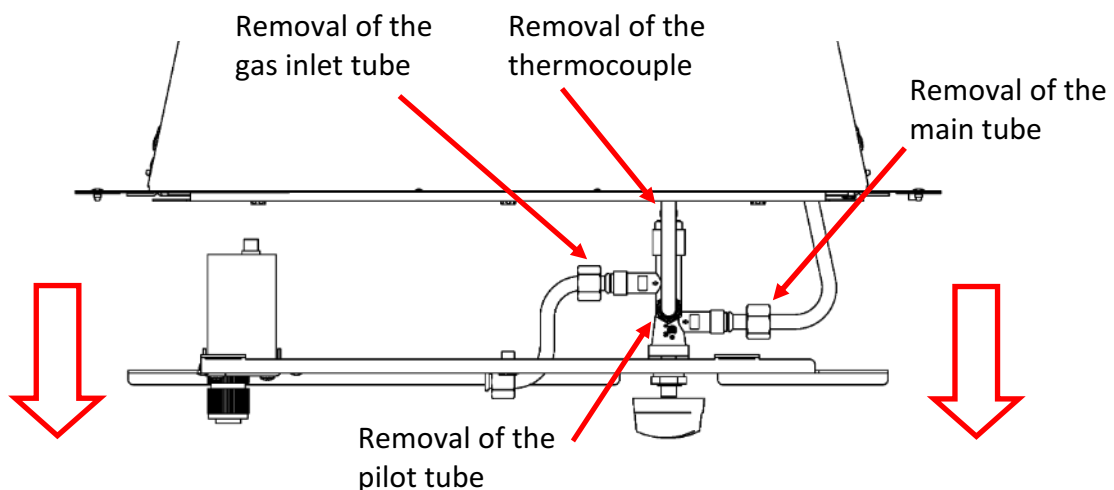

Removal/Replacement of the manual Valve—continued.

Removal of the knob and the valve nut.

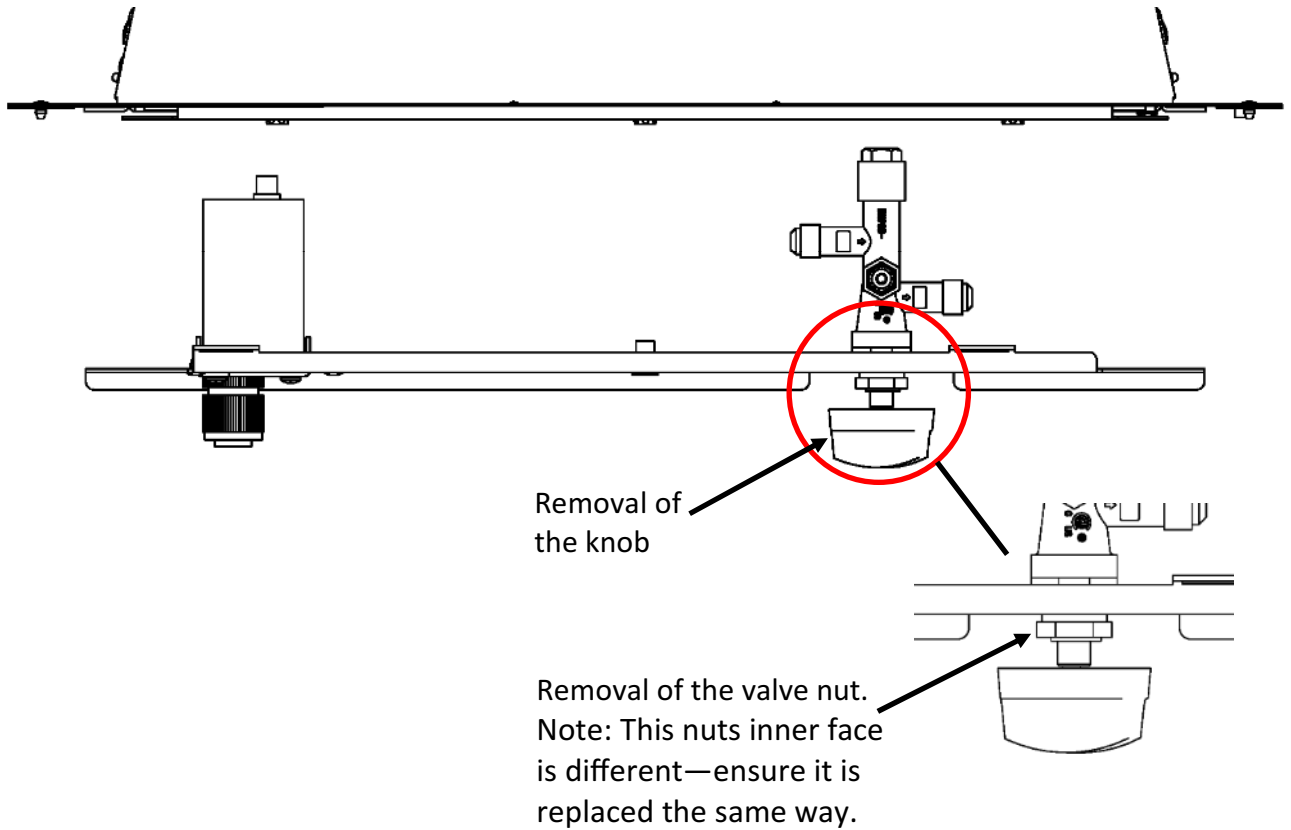

Removal/Replacement of the Aeration plate.

The aeration plate on the injector bracket as shown below, removing the 2 screws, this plate can be removed.

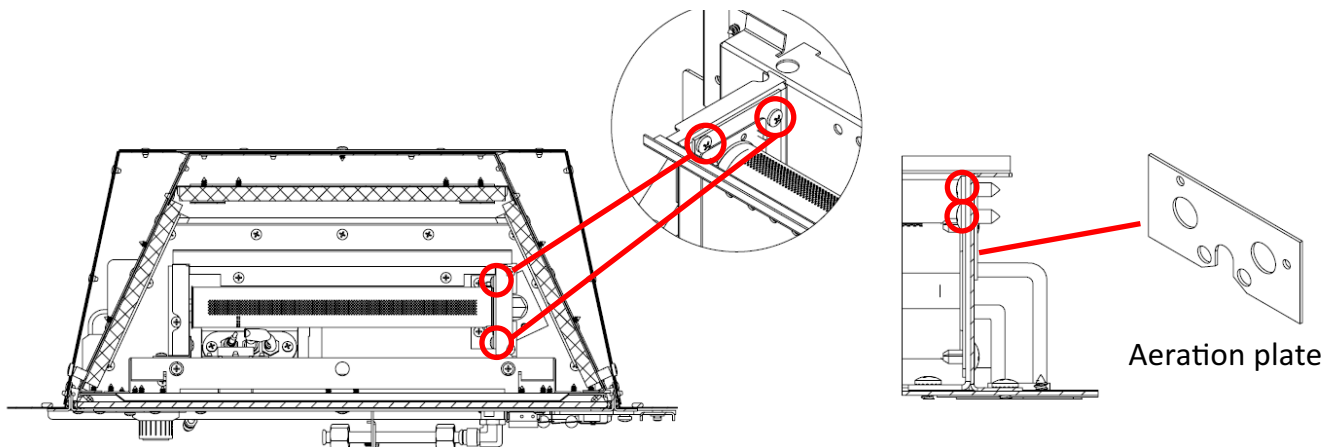

Removal/Replacement of the Pilot Assembly and Thermocouple (For Slide Control)

Remove the locking nut from the base of the thermocouple.

Remove the thermocouple nut from the end of the gas valve.

Remove the two small screws (blue circle) to release the microswitch.

The Thermocouple can now be removed.

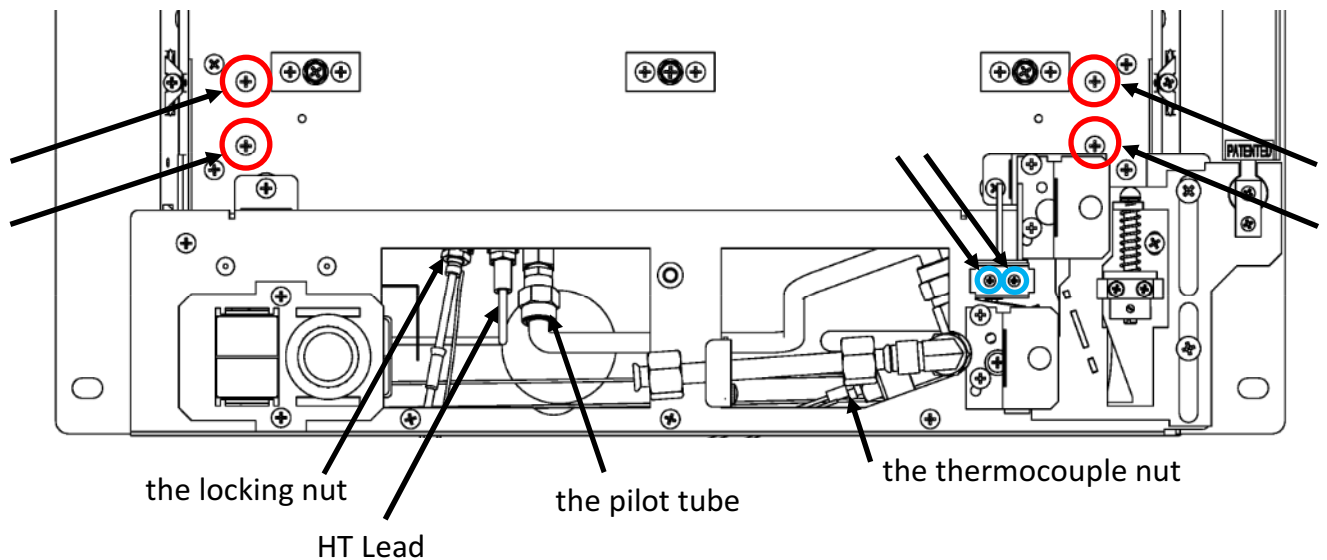

Remove the HT Lead from the pilot.

Remove the pilot gas tube nut from the pilot.

Remove the 4 screws (red circle) as shown above.

Remove the 3 screws as shown below to remove the front coal support.

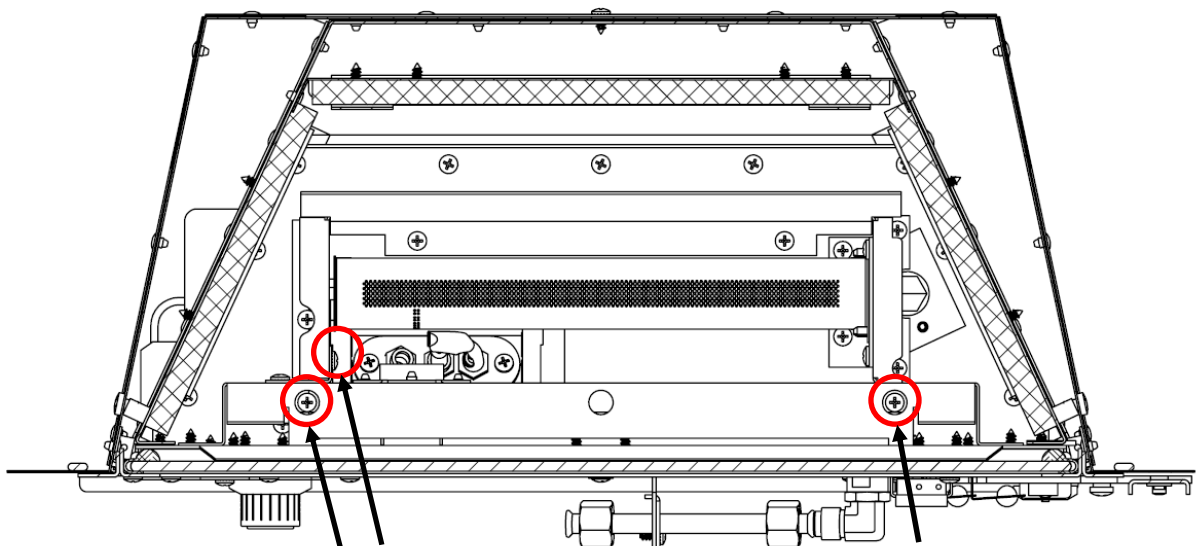

Removal/Replacement of the Pilot Assembly and Thermocouple (For Slide Control) — continued.

Remove the 2 screws as shown below to remove the Pilot Assembly.

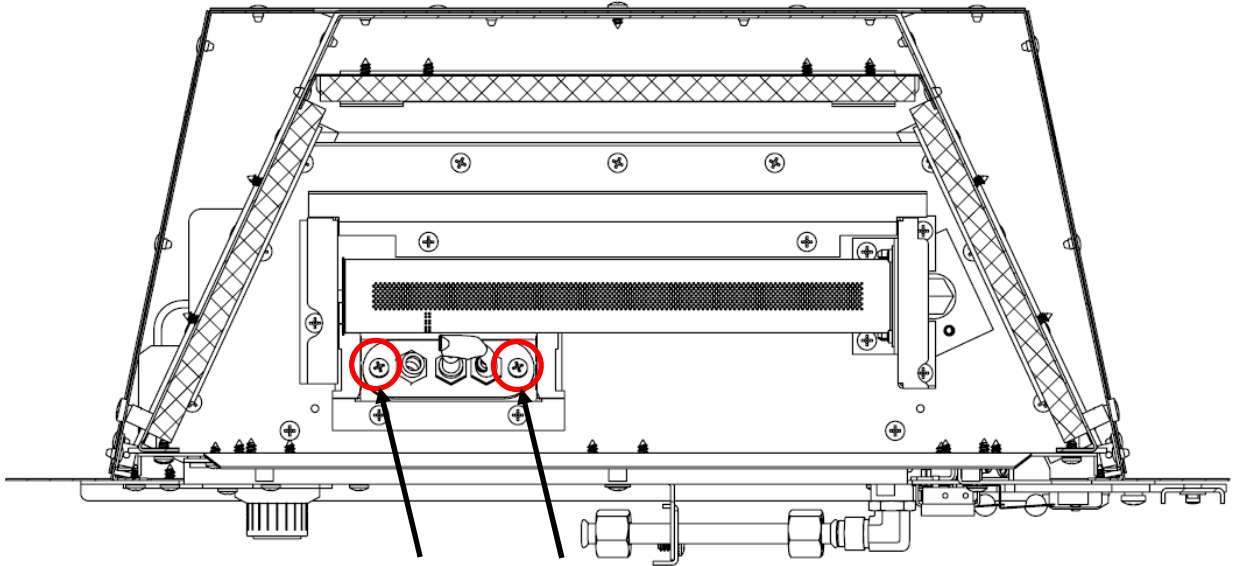

Removal/Replacement of the Pilot Assembly and Thermocouple (For Manual Control)

Remove the 7 screws shown in this diagram.

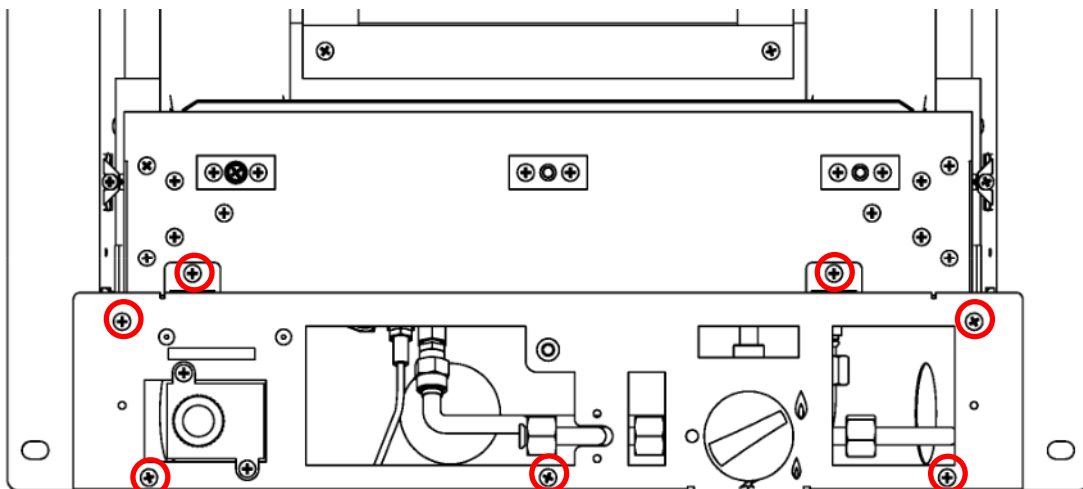

Removal/Replacement of the Pilot Assembly and Thermocouple (For Manual Control) — continued.

Gently ease the front tray forward, the gas pipes are flexible but take care when moving to ensure the pipes move uniformly as it is removed.

It should only be pulled forward to gain access to the main gas outlet port on the rear face of the valve.

Remove the thermocouple from the back of the valve.

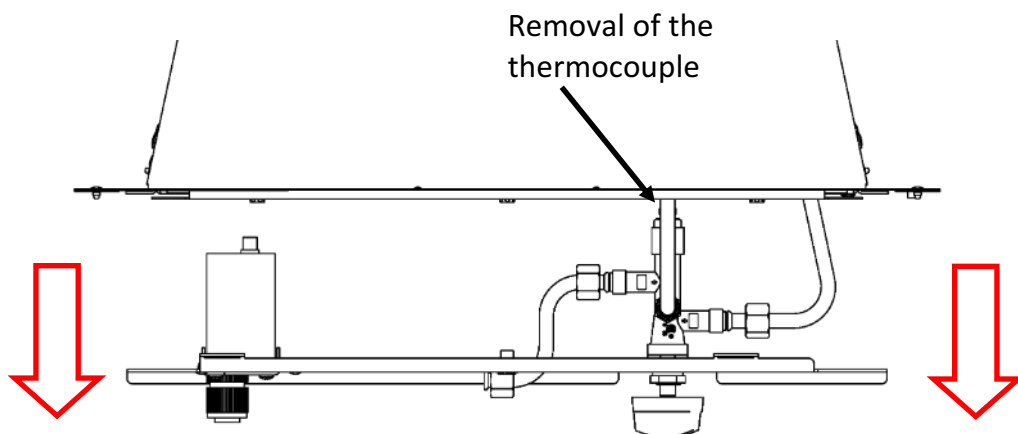

Remove the locking nut from the base of the thermocouple.

The Thermocouple can now be removed.

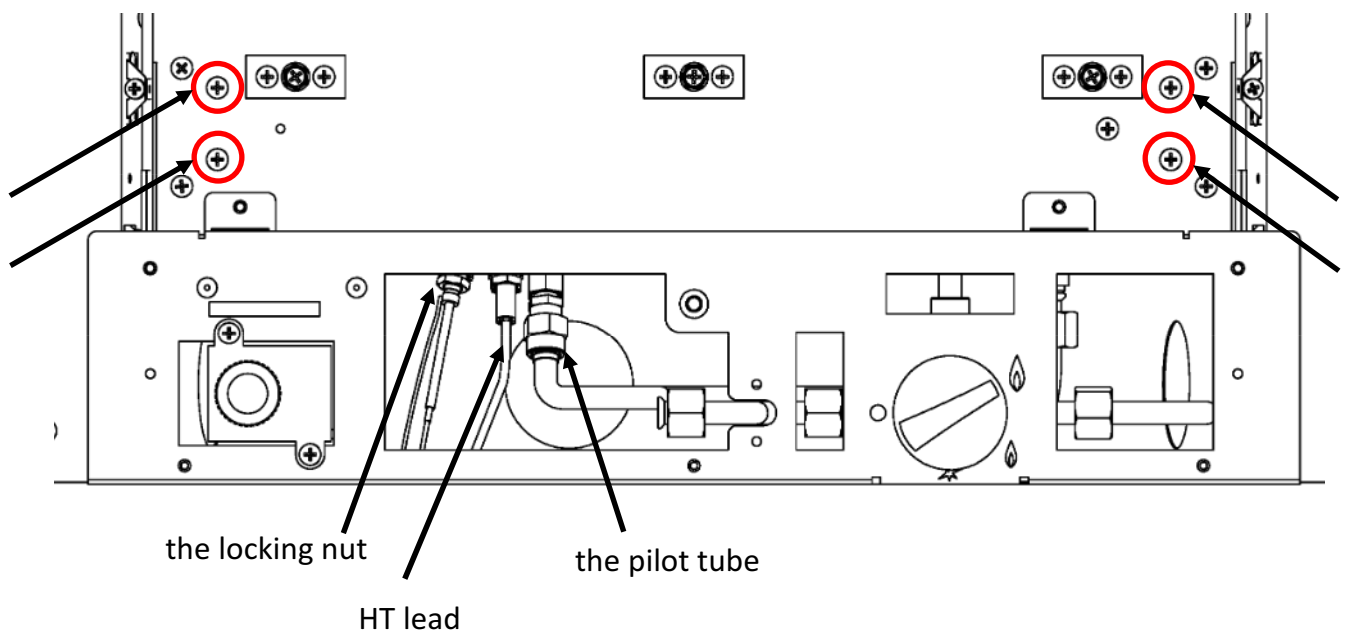

Remove the HT lead from the pilot.

Remove the pilot gas tube nut from the pilot.

Remove the 4 screws as shown above.

Removal/Replacement of the Pilot Assembly and Thermocouple (For Manual Control) — continued.

Remove the 3 screws as shown below to remove the front coal support.

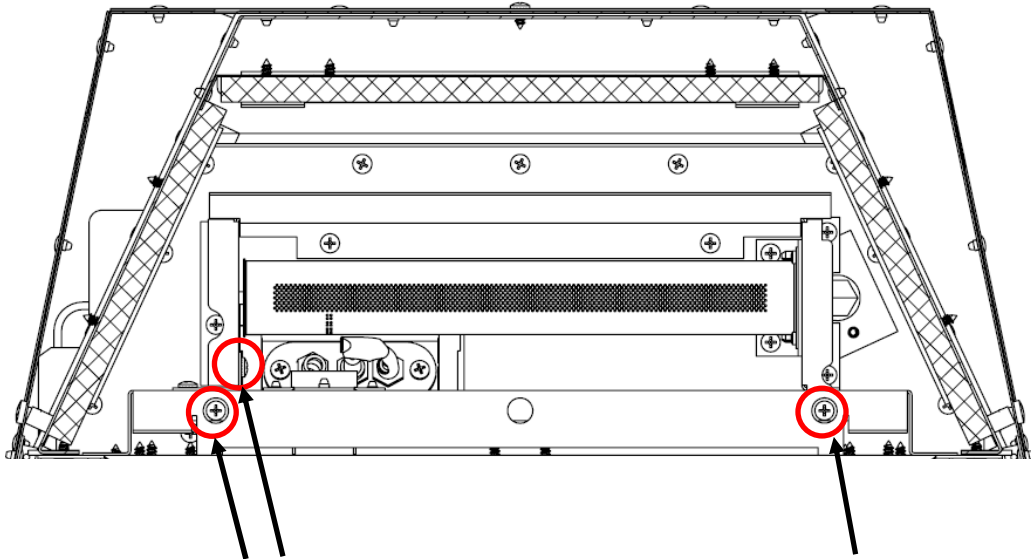

Remove the 2 screws as shown below to remove the Pilot Assembly.

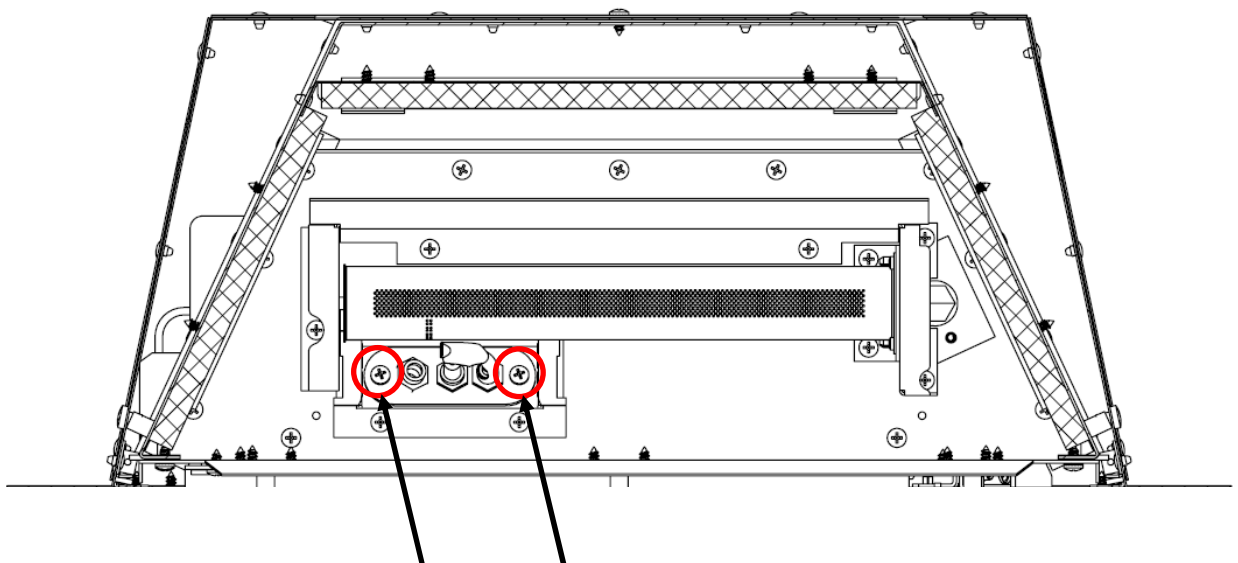

Removal/Replacement of the Injector.

Remove the 6 screws, there is an aeration plate on the injector bracket as shown below, do not forget this when reassembling. Then take out the burner as shown below.

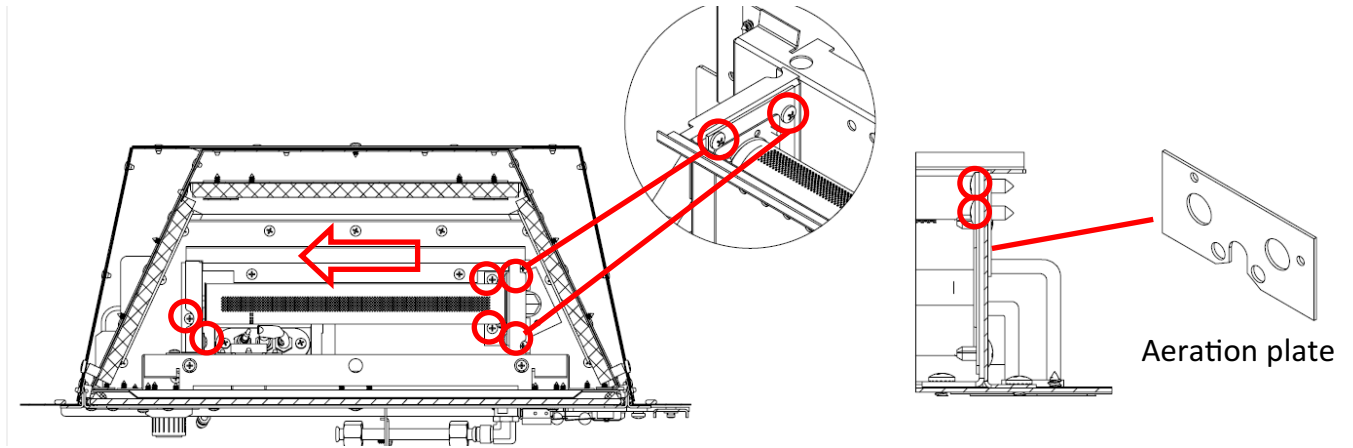

The injector can now be removed.

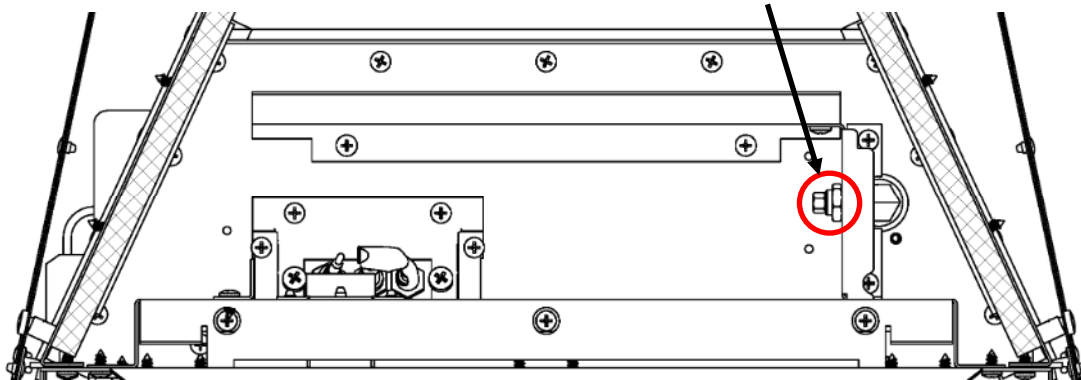

Removal/Replacement of the Tray

Remove all screws as shown below.

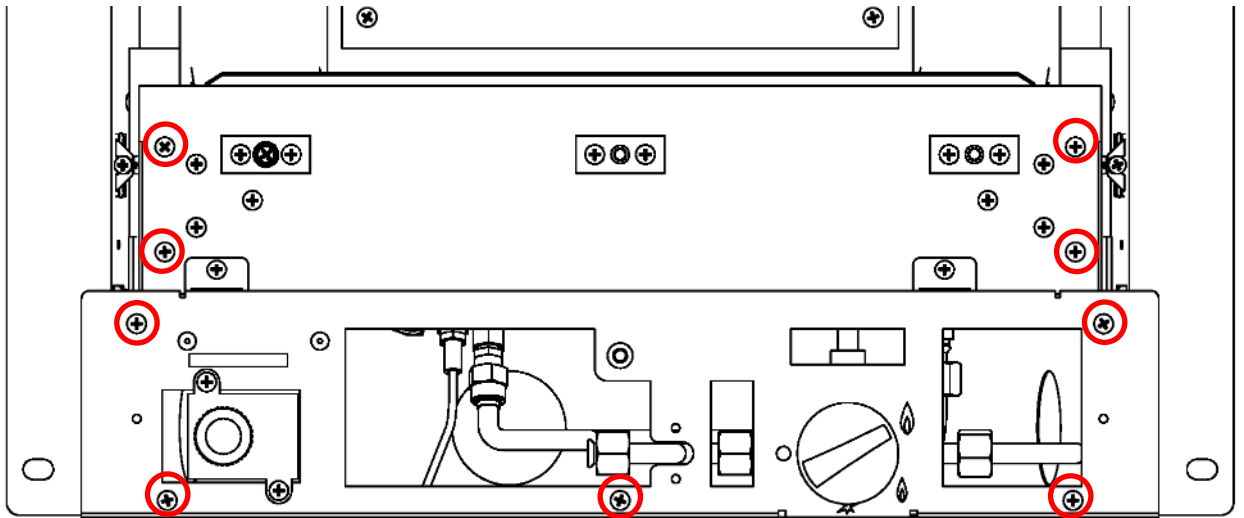

Manual Control

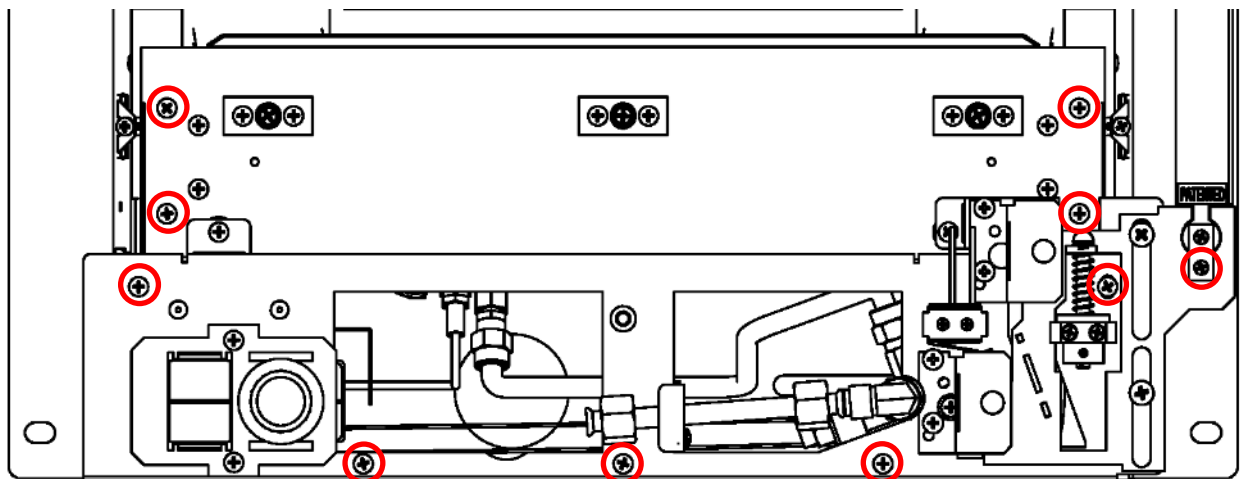

Slide Control

Remove the 2 blue circle screws, and then remove the 9 red circle screws as shown below.

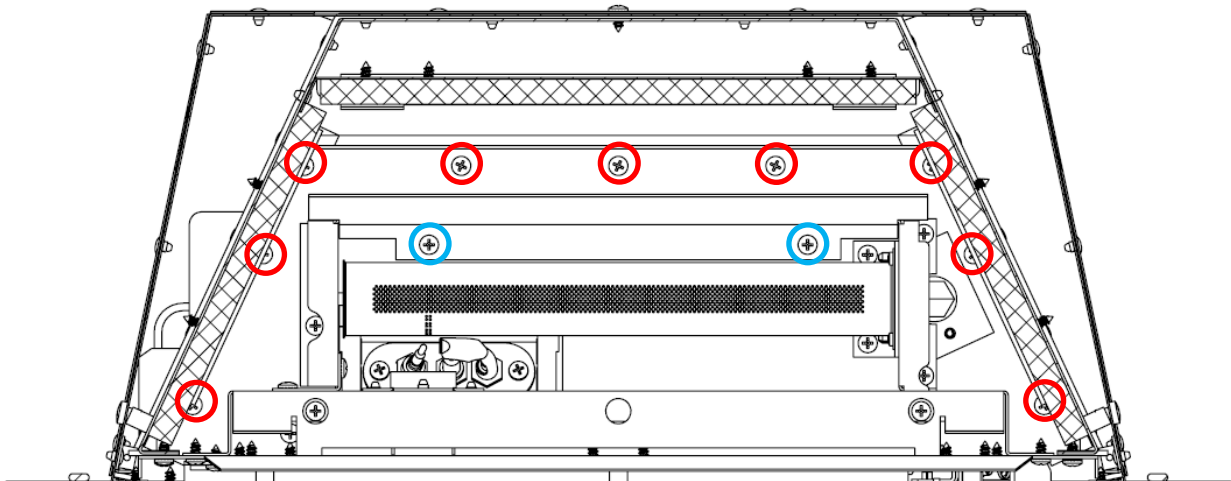

Removal/Replacement of the Ceramic Plate

Remove the 4 screws shown in the diagram below, the Side Ceramic Plate can be removed.

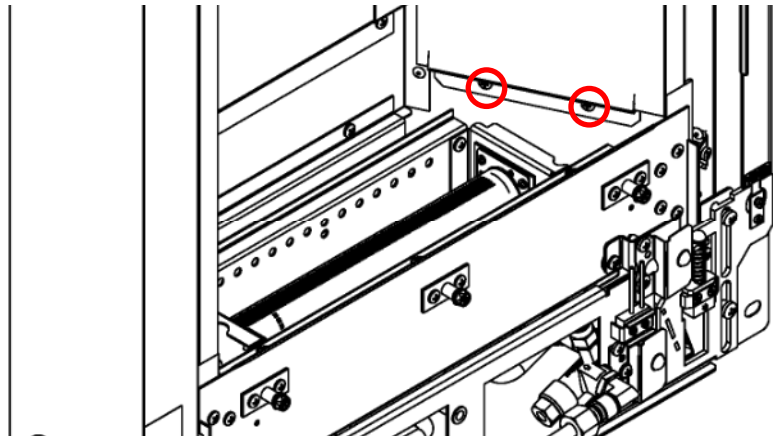
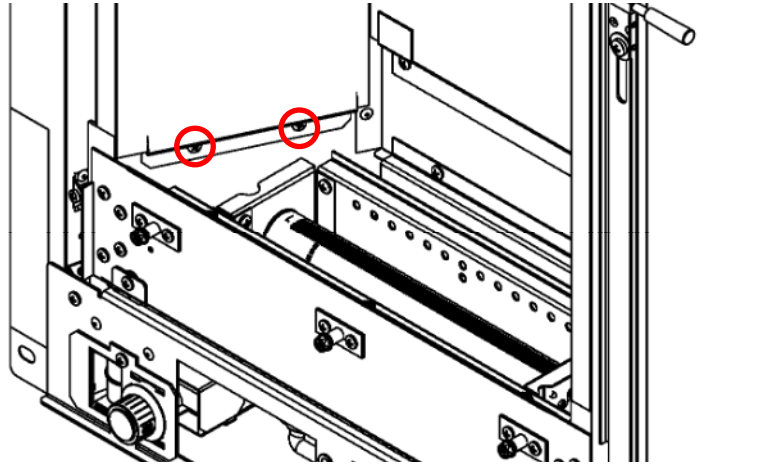

Then remove the 2 screws shown in the diagram below, the Rear Ceramic Plate can be removed.

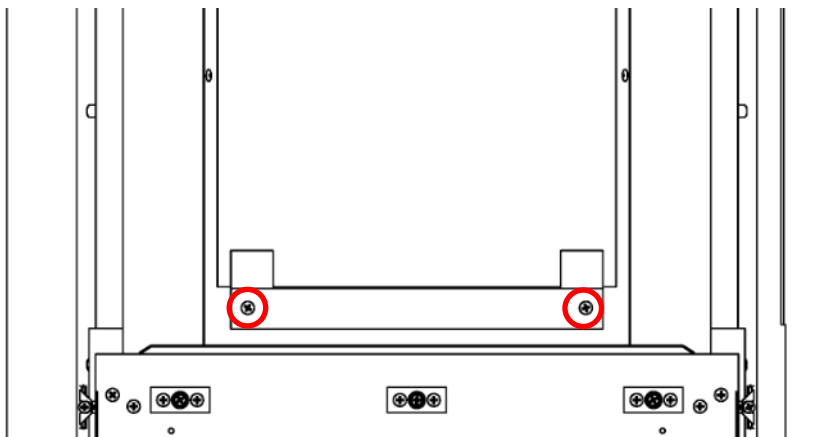

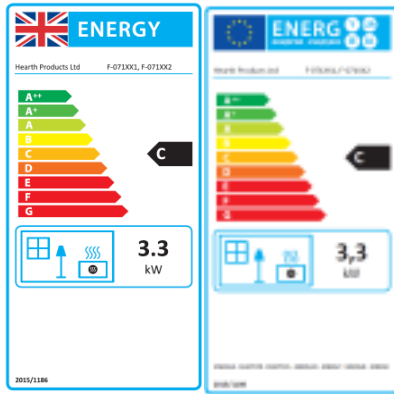

Product Fiche		
Manufacturer :	Hearth Products Ltd	
Model No.	F-071XX1	F-071XX2
Fuel Type	Natural Gas I2H	Natural Gas I2H
Energy Efficiency Class	C	C
Indirect Heating Functionality	No	No
Direct Heat Output kW	3.3kW	3.3Kw
Indirect Heat Output kW	N/A	N/A
EEl	77%	77%
Useful Energy Efficiency (NCV)	High : 86.4%	86.4%
Useful Energy Efficiency (NCV)	N/A	N/A
Nominal Heat Output	High : 3.3kW	High :3.3kW
Nominal Heat Output	Low : 2.1kW	Low : 2.1kW
Heat Output Temperature Control	Two Manual Stages	Two Manual Stages
Permanent Pilot Power (kW)	N/A	N/A
Space Heating Emissions NOx (GCV)	130mg/kWh	130mg/kWh

Important Note:

The energy efficiency class of this product is defined using a seasonal efficiency calculation which reduces the actual net efficiency of the product where the use of automated heat control, thermostats, window open sensors and timers are not used. This is not to be confused with the net efficiency, or useful efficiency of the appliance (shown in the tables above).

**This product MUST be installed by a Gas Safe Registered Installer. Full details are provided in this manual.
 Hearth Products Ltd. Unit 14 Tollgate Industrial Estate, Stafford, ST16 3SU**

User Replaceable Parts

Part Number	Description
P-XX1187	Ceramic Fuel Bed-Coal Set
P-XX140007A	Glass Door Assembly



Hearth Products Ltd
Unit 14 Tollgate Industrial Estate,
Stafford, ST16 3SU

www.hearthproducts.co.uk

Tel: 01785 225401 Fax: 01785 225501

Email: info@hearthproducts.co.uk



Due to our policy of continual product improvement, some diagrams and small details may not be accurate however if there is any concern or matter of understanding that you feel needs to be clarified please contact us directly. Our contact details are shown below.