

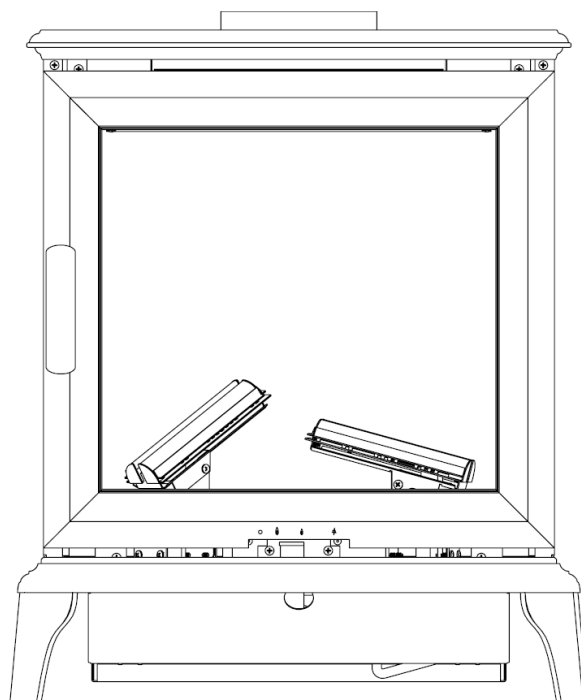

RAVEL STOVE GAS LOG FIRE CONVENTIONAL FLUE



USER INSTRUCTIONS INSTALLATION INSTRUCTIONS SERVICE INSTRUCTIONS

Do not use this appliance if the front glass panel is broken, removed or fitted incorrectly.

It is a regulation that these instructions be handed to the customer after installation is complete. It is also the responsibility of the installation engineer to ensure that the customer is able to fully operate the appliance and is aware of any cleaning or maintenance requirements.

Model number: F-131XX2 SLIDE For use on Natural Gas (G20) at a supply pressure of 20 mbar in GB



**THIS INSTRUCTION MANUAL MUST BE LEFT
WITH THE CUSTOMER AFTER INSTALLATION**

This product is not suitable for primary heating purposes.

USER INSTRUCTIONS	1.0	Appliance Commissioning Check List	3
	2.0	User Instructions—Important information & Warnings	4
	2.1	User Instructions—Controls & Operation	5
	2.2	User Instructions—General Maintenance & Cleaning	6
	2.3	Log Layout Instructions	9
	2.4	Running in and Troubleshooting	14
	3.0	Unpacking the appliance	15
	3.1	Regulatory Information	16
	3.2	Efficiency and Appliance Technical Information	16
	3.3	Installation Requirements	16
INSTALLATION INSTRUCTIONS	3.4.0.1	Top flue Siting Requirements	17
	3.4.0.2	Rear flue Siting Requirements	17
	3.4.1	Hearth Requirements	18
	3.4.2	Checking the Flue	18
	3.4.3	Stove Dimensions	18
	3.4.4	Clearance from combustibles / non combustibles.....	19
	3.4.5	Back Panel Requirements	20
	3.4.6	Debris	20
	3.5	Ventilation Requirements	20
	3.6	Gas Supply	20
	3.7	Rear Flue Installation (Optional)	21
	4.2	Connecting the Gas Supply	24
	4.3	Log Layout Instructions	25
	4.4	Lighting the Fire	30
	4.5	Check for Spillage	31
	4.6	Complete the Installation	32
	SERVICING INSTRUCTIONS	5.0	Servicing the Appliance
5.1		Removal the Burner Tray	34
5.2		Removal of Pilot	35
5.3		Removal of the Slide Gas Valve	37
5.4		Removal of Spark Generator	38
5.5		Removal of the Tee Valve (High Setting)	39
5.6		Removal of the Injectors	40
6.0		Record of Annual Services	42
7.0		Product Fiche	43
8.0		Manufacturers Instructions and User Replaceable Spares	44

1.0 APPLIANCE COMMISSIONING CHECKLIST

It is the installers responsibility to complete the following checklist when commissioning this appliance. The information recorded on this page may be requested at the time of any warranty call made. If the information is not made available it may affect the warranty support for the customers appliance.

CHECK LISTS	PASS	FAIL
Check flue is suitable for this appliance		
Check flue flow prior to installation		
Check spillage after installation		
Check standing gas pressure		mbar
Check working pressure on full rate (Min. 18.5) Ensure all other gas appliances are running on full rate		mbar
Complete relevant section of warranty forms , ensure it is complete with Gas Safe registration details.		
Instruct the customer on lighting, maintenance and servicing procedures. (Including glass removal and ceramic placement)		

Appliance Serial Number	
Installation Date	
Gas Engineer Name	
Gas Safe Engineer Registration No.	
Gas Safe Engineer contact No.	

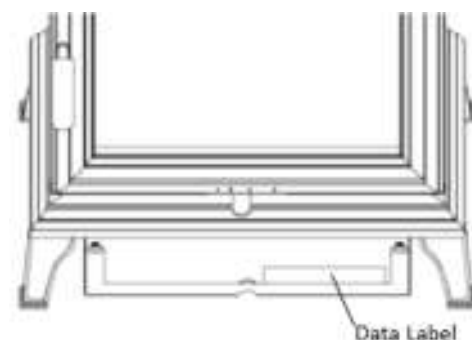

If you can smell gas, immediately turn off the gas supply using the control valve at the meter in your home. Do not smoke and turn off all sources of ignition, i.e. boilers or gas hobs. Open windows and doors to ventilate the room or building.

Call the Gas Emergency Service 0800 111 999 (England Scotland and Wales)
0800 002 002 (N. Ireland)

WELCOME

2.0 Congratulations on the purchase of your new Wildfire Ravel Gas Stove. Ensure you keep these instructions in a safe place as they will be required for installation, service and general upkeep of your appliance.

These instructions should be followed precisely to ensure that you receive many years of trouble free service from your appliance.

Some general maintenance is required by the user to keep the appliance in its best condition, these are detailed later in this instructions manual.

IMPORTANT

This gas appliance **MUST** be installed by a GAS SAFE registered installer by law. It must be installed in accordance to these installation instructions and the GAS SAFETY (Installation & Use) REGULATIONS 1998 as amended. Non compliance of this law may lead to prosecution and it is in the interest of you and your family that this condition is observed. Check with your gas installer that they have current membership to Gas Safe and that their membership includes gas fires.

It is very important that you also have your gas appliance serviced annually by a Gas Safe registered engineer. During this service the engineer will check the operation and performance of the appliance and also for any debris that may have collected above or behind the appliance, depending on installation type. This is important for you and your families safety

Check for the Gas Safe logo on your gas engineers membership card.



WARNINGS

Do not place soft wall coverings (i.e. embossed papers etc,) furniture or other combustible items too close to the fires as they may discolour or scorch.

Do not place or throw rubbish or otherwise on the fuel-bed.

Do not place any combustible materials or flooring (i.e. carpets etc,) on any part of the hearth.

Many parts of this appliance and some surrounding areas will be come hot during use.

This appliance has a naked flame and as with all heating appliances a fireguard should be used for the protection of children, the elderly and infirm. The fireguard should conform to BS8423 : 2002 (Fireguards or use with Gas Heating Appliances).

It is quite normal for a flame effect gas appliance to experience a small amount of soot or staining to some parts of the fuel effect components. If this becomes excessive it may be because the fuel bed is not fitted correctly — this should be checked according to these installation instructions prior to contacting a service engineer.

NEVER place any rubbish or otherwise onto the fire—this will affect the way the product operates and may affect the warranty of the product.

NEVER place more ceramic components onto the fuel bed than specified in the instructions.

NEVER touch the ceramics when the appliance has recently been switched off—these components retain heat and may cause burns. Leave the appliance to sufficiently cool prior to any contact of the ceramics.

VENTILATION

No purpose made ventilation is normally required for this appliance when installed in G.B. If the appliance is being installed in I.E then refer to I.S 813:1996 (Domestic Gas Installation—National Standards Authority of Ireland). Ventilation areas (if applicable) should be checked periodically to ensure there is no obstruction, even though none is normally required for this appliance.

Controls

2.1 This appliance has a slide control lever. It is positioned in the space between door and the stove base plate.

The lever will slide from left to right, this movement controls all functionality of the appliance, from ignition, flame control and turning the appliance off.

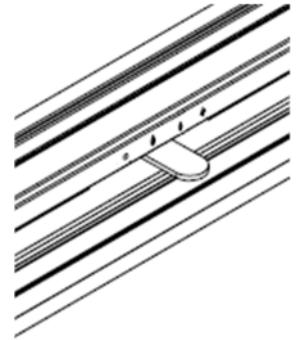

Lighting

Slide the control knob to the right to the ignition symbol. After a few seconds the pilot light should light.



If the pilot light does not light, release the control knob and wait for 3 minutes before reattempting. If the pilot does not light after 3 attempts, check the battery—see page 6. If the battery is new and the pilot still fails to light, contact a gas safe engineer.



Once the pilot is lit, keep the lever pushed to the right for up to 10 seconds then release. The pilot should stay lit and the central and front log burners will now light.

The appliance is now running at the LOW setting.



Slide the knob slowly to the left to turn the rear log burners on. The appliance is now running at the HIGH setting.



To turn the fire off, slide the lever all the way to the left to the OFF symbol.



Should the spark generator fail to provide a spark at the electrode it may be that a small amount of soot has fallen from the fuel bed onto the pilot assembly, causing a short circuit. If this is the case, ensuring the appliance is off and cold, this area can be cleaned with the thin nozzle from a vacuum cleaner. See page 6 for details on glass removal to access this area.

Alternatively check the battery is in good condition—see page 6 for details.

BATTERY

2.2 This gas appliance uses a single AA type battery which supplies the power for the spark generator used during the ignition process. The battery box which houses this battery is located beneath the appliance behind the drop down access hatch.

Remove the black battery cap to access the battery compartment as shown in the diagram. Replace the battery ensuring correct polarity.

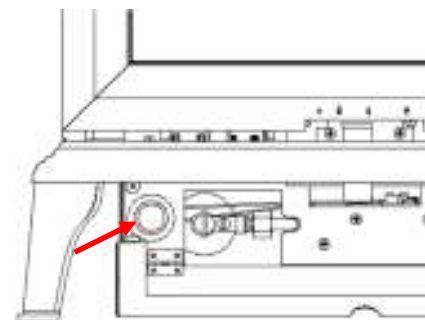

GLASS DOOR

The glass door can be removed for cleaning or to access the ceramic logs and pilot area for maintenance.

There are two Philips screws located each side of the control lever in the gap between the door and the stove base plate. Carefully remove these screws to release the door frame from the assembly.

Once released, the door frame can now be lifted vertically upwards. There are two capture points on the left and right side of the door frame which must be cleared before the door frame will come away from the stove—it is important to keep the door frame square whilst it is lifted to allow it to become free.

With the door frame removed, the two top glass retaining clamp can be seen.

Loosen these two screws carefully and the retaining bar and the glass panel can now be removed, providing access to the burner chamber.

Store the door frame where it cannot be damaged.

Never run the appliance with a damaged or broken glass panel

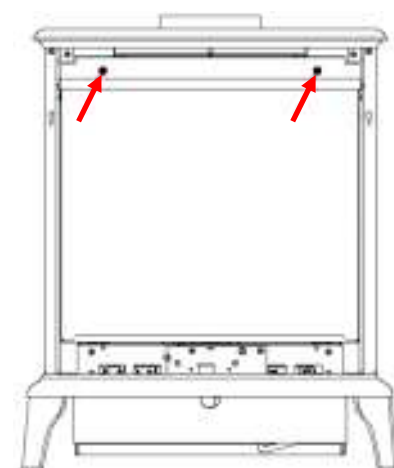
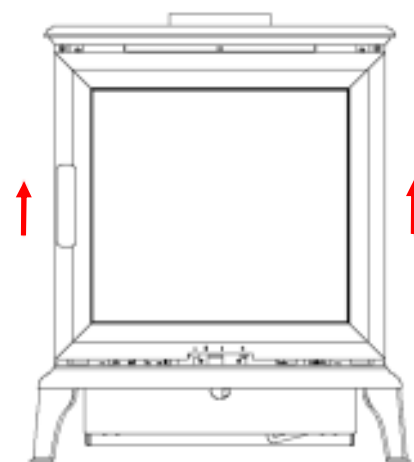

CLEANING

Cleaning is recommended for some parts of this appliance. The glass can be cleaned with a non abrasive glass cleaner and lint free cloth. Metal parts can be cleaned with a lint free damp cloth.

Fuelbed

HEALTH AND SAFETY NOTICE

This appliance uses fuel effect pieces manufactured from Refractory Ceramic Fibres (RCF). Care must be taken to avoid excessive exposure to these materials as they may cause irritation to the eyes, skin, nose and throat. When Handling avoid inhaling and contact with skin and eyes. It is recommended that disposable gloves are worn in addition to a facemask and eye protection. After handling wash hands thoroughly and any other exposed parts which may have come in to contact with the material.

If a vacuum cleaner is used to clean the fuel bed or areas around the appliance there fragments of the material may have fallen it is recommended that it be of the type fitted with a **HEPA** filter.

Care should be taken when disposing of RCF materials. It is important to keep any dust to a minimum so it is recommended that the fuel effect components are placed into a heavy duty plastic bag. The bag should be clearly labelled **RCF WASTE**. These materials are not classified as hazardous waste and should be disposed of at a site approved for the disposal of industrial waste.

The fuel effect components supplied with this product are extremely fragile and must be handled with great care. The ceramics in this appliance are not covered by the warranty due to their fragility. This includes the RCF fibre boards in the fire box. These components will break or chip if not handled with the greatest of care.

Cleaning of these components should only be undertaken once the appliance is switched off and has been allowed to cool for a minimum period of one hour. The components should be lifted carefully piece by piece from the appliance and placed onto a dust sheet or similar. They can be brushed gently with a soft brush to remove any dust or deposits. If you intend to use a vacuum cleaner then this should only be done once the loose deposits of soot etc have been removed. Ensure that the moulded components are structurally sound and no significant part of the moulding has broken away. If any component has broken then it should be replaced before using the appliance. Only the correct replacement part as supplied by the manufacturer shall be used in this appliance. Do not add any additional components to the fuel bed layout. It is important to note that small hairline cracks will appear in the surface of the ceramics due to heat expansion and contraction—this is perfectly normal.

See the full details of log and fuel bed installation on page 9 for removal and replacement of the ceramic log, ember wire and bark components.

PILOT

It may be necessary to clean areas around the pilot assembly. If the appliance is running and then turns itself off automatically for no apparent reason, it may be that the O.D.S (oxygen monitoring device) has become partially blocked and may need to be cleaned. This can also be caused by sudden excessive down draft so only attempt pilot cleaning if this occurs repeatedly.

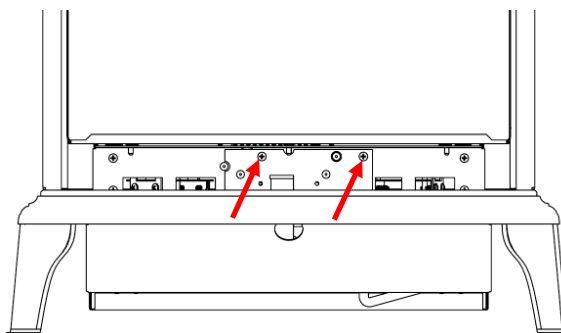

The pilot can be found behind the cover shown in this diagram.

The pilot to this appliance has a small aeration hole at its base, sometimes lint and dust can be drawn in with the air supply to the pilot.

To reduce the occurrence of such lint ingestion it is recommended that the area directly in front of the appliance is cleaned regularly. This problem can be worse where wooden floors are present, as lint is more free to move on these areas. Pet hair can also cause this problem.

Using a thin nozzle on a vacuum cleaner this area can be cleaned to remove any lint build up. Apply the end of the nozzle to the aeration hole for up to 2 minutes, regularly removing and reapplying the tip of the nozzle to vary suction.

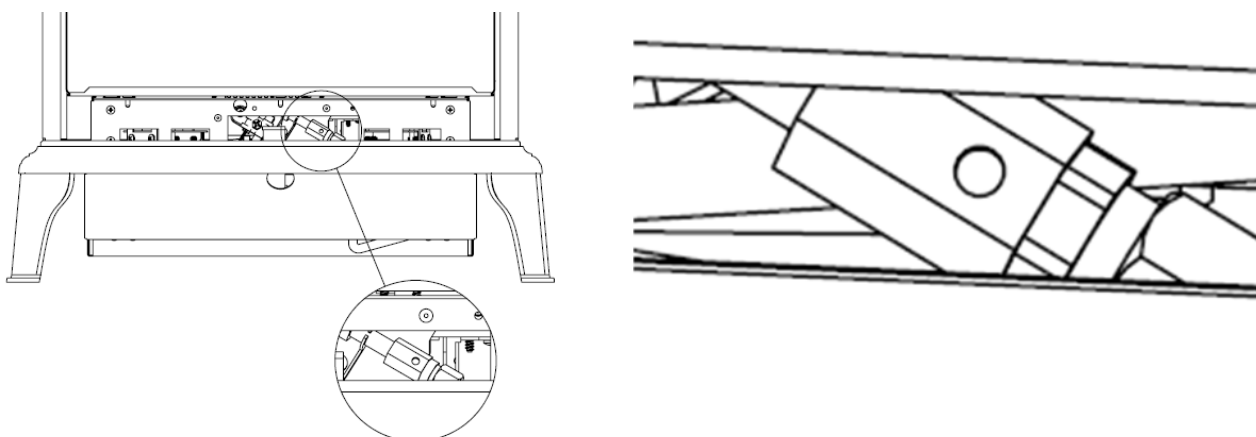

If this procedure does not resolve such a problem then the pilot assembly will need to be replaced. This must involve the installation of the same part as supplied by the manufacturer. Excessive lint build up which results in appliance operational problems is not covered by warranty. It is important to ensure this preventative maintenance is performed regularly.

LOG SETUP

2.3 The following instructions detail how the ceramic fuel bed and loose components are to be installed onto the appliance. Great care should be taken when handling these ceramic parts as they are fragile and can easily be broken. Do not force any component into position, if it does not fit easily then you are not fitting the part correctly. These instructions can also be followed to remove or reinstall the fuel bed after cleaning. This is a procedure that can be undertaken by the customer as required and the frequency will be depend upon use.

See page 6 for glass door removal and installation.

The fuel bed setup involves the installation of volcanic rock, ceramic bark, ember wire and a boxed set of ceramic decorative logs. These components will have been installed by your gas engineer at the point of installation, however it is permitted for the end user to remove clean and replace these components as necessary. The following installation instructions must be adhered to at all times.

The following diagram is for identification purposes. It is imperative that the logs are placed in the correct position for safety and also to ensure that you obtain optimal performance from your

IDENTIFY

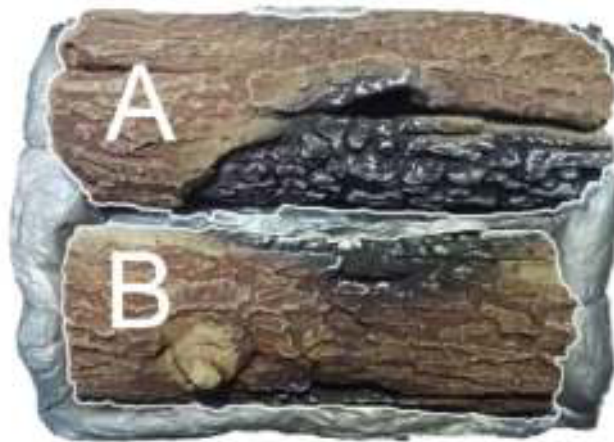

FUELBED

Place the volcanic rock on top of the centre burner as shown. Ensure a 1-2 mm gap is left between each piece. Then using **quarter** of the glowing ember wire supplied, ruffle between fingers to make it loose, about 20mm wide and as long enough to cover the volcanic rock then align over the rock as shown. Ensure no wire is placed within 25mm of the pilot assembly. Retain the rest of the wire for replacement at annual service.



Place Log D as shown in the picture.



Place Log C as shown in the picture.



Place Log E as shown in the picture.



Place Log A as shown in the picture.



Place Log B as shown in the picture.



Place Log F as shown in the picture.



Place Log G as shown in the picture.



Running In

2.4 When this appliance is first used it is important to note that you will experience some fumes and smells in the room of operation. Any fumes emitted during the first few minutes of use can be quite pungent and it is advised that a window is opened until this subsides. Smells associated with paints, oils and starch from ceramic components may last several hours but will rapidly diminish over the first few uses of the appliance.

It is advisable that the appliance is always run on high for a period of at least 20 minutes before turning to low, to ensure optimal flue performance and to reduce the possibility of sooting.

It should be noted that as with all flame effect gas appliances, some sooting can be evident and can be cleaned away—see cleaning instructions on previous pages.

Trouble Shooting

The following table should be used to identify any problems experienced with the operating or running of your appliance prior to contacting the manufacturer or retailer regarding service.

THE FIRE WILL NOT LIGHT

Can you hear a continuous clicking during the ignition process?	YES ↓	NO Check Battery
Does the pilot light?	YES ↓	NO Check and remove soot or ember wire near the pilot
Does the pilot go out when the lever is released?	YES →	Try again, but before releasing the lever give a firm push to the left before releasing the lever.

THE FIRE GOES OUT

Does the fire light and run ok then subsequently turns off automatically	YES →	The pilot aeration may have become blocked refer to page 8
--	-------	--

VISUAL PROBLEMS

Does the flame picture look wrong?	YES →	Check log placement as per the user instructions see pages 9-13
Does the glass have grey water marks on inside surface	YES →	The glass will require infrequent cleaning dependant on use. See page 6 to open door.
Do you see marks or discolouration above the centre of the appliance?	YES →	The gas fire is spilling, turn the unit off and call for your gas safe engineer.

Warranty



The Wildfire 5 year limited guarantee is managed directly by Hearth Products Ltd. With our experienced Gas Safe engineers and through our extensive network of service centres throughout the UK we will ensure your appliance receives the right care should anything fail prematurely. Choose Wildfire for style, performance, reliability, value and peace of mind. Note that it is a condition of the extended warranty that the appliance is serviced annually.

Unpacking
appliance

3.0 TAKE GREAT CARE WHEN UNPACKING THE APPLIANCE—SOME PARTS CAN BE EASILY DAMAGED.





Once the carton has been opened, carefully remove the polystyrene packing components to reveal the appliance. Carefully remove the appliance from the packaging then remove and check the accessory packs before commencing the installation.

There will be **two** plastic bags also located in the carton:

Instructions and guarantee registration form. Note that the guarantee registration can be performed online at:

www.hearthproducts.co.uk/register-new-product/



TOOLS & FITTING PACKAGE			
ITEM	PICTURE	DESCRIPTION	QTY
1		ISOLATION ELBOW	1
2		ALUMINIUM TAPE	1
3		EMBER WIRE	1
4		DEBRIS DIVERTER	1

REGULATORY INFORMATION

3.1 NOTE THE FOLLOWING PRIOR TO THE INSTALLATION OF THIS APPLIANCE.

This gas appliance **MUST** be installed by a GAS SAFE registered installer by law. It must be installed in accordance to these installation instructions and the GAS SAFETY (Installation & Use) REGULATIONS 1998 as amended. Non compliance of this law may lead to prosecution and it is in the interest of you and your family that this condition is observed.



The installation of this appliance must be in accordance with the relevant parts of the LOCAL AND NATIONAL BUILDING REGULATIONS as issued by the Department of the Environment or BUILDING STANDARD (Scotland Consolidation) REGULATIONS issued by the Scottish Development Department and the following relevant British Standards:

BS5871	Part 2 Installation of Inset Live Fuel Effect Gas Fires
BS5440	Parts 1 & 2 Installation of Flues and Ventilation
BS6891	Installation of Gas Pipe-work
BS6461	Part 1 Installation of Chimneys and Flues
BS1251	Open Fireplace Components
BS715/BS EN 1856-2	Metal Flue Boxes /Metal Flue Pipes for Gas Appliances
BS EN 1858 / BS1289	Chimneys Components & Concrete Flue Blocks
IS813:1996	Domestic Gas Installation (Republic of Ireland)

Efficiency / Technical

3.2 The efficiency of this appliance has been tested to BS 7977-1:2009+A1:2013 and the result is 82.2% net (74.0% gross). This efficiency value has been verified by Kiwa (0558). This efficiency value can be used for SAP (Standard Assessment Procedure) for energy rating of UK dwellings.



Appliance Technical Information

GAS TYPE: NATURAL	GAS CATEGORY: L _{2H}	INLET PRESSURE: (COLD)20mBar
HEAT INPUT: GROSS 4.25kW	INJECTORS: 0.71 (5)	DEST. COUNTRIES: GB

INSTALLATION REQUIREMENTS

3.3 Prior to installation ensure that the gas supply is compatible with the appliance, this appliance must only be used on **natural gas** at a supply pressure of 20mbar as marked on the data plate on the appliance and the carton. This appliance can be installed below a masonry chimney which must be constructed of non-combustible materials confirming to BS1251 or into a suitable non-combustible chamber with prefabricated flue complying with the requirements of BS715 / BS EN1856-2. The appliance can also be installed in front of a class 1 builders opening.

This fireplace is also suitable for installation into precast flue fireplaces which comply to the requirements of BS EN1858/ BS1289-1:1986 / BS1289:1975 and must have a cross sectional area of at least 12500mm² for BS1289:1975 and 16500mm² for BS1289-1:1986 pre cast flues.

When installing into a precast flue it is extremely important to ensure that the flue is clear of spiders webs and any other material which could impede the flow of products. Furthermore the flue-way connecting the blocks to the terminal should be twin skin and preferably insulated to reduce heat loss. If the flue terminates in a ridge tile which is too restrictive it may be necessary to change to a less restrictive ridge terminal.

The flue or chimney must be at least 3 metres in height and if previously used for the burning of solid fuel (e.g coal or wood) should be swept before. The chimney must only serve as a flue -way to this appliance and must have no openings to any other room. The opening should be inspected and any exposed brickwork should be repaired where necessary. Ensure that the chimney/flue only serves one fireplace. Remove or securely fix open and dampers or register plates.

The flue should be checked for draw using a smoke bomb or similar, if there is a definite draw then the installation of the appliance can proceed.

TOP FLUE SITE REQUIREMENTS

3.4.0.1 For this type of installation the chimney or flue must be either Class 1 (brick chimney or 7" diameter flue) or Class 2 (5" diameter flue) The minimum effective height of the flue must be 3 metres, (10'). The flue must be clear of obstruction and if the previous installation was intended for solid fuel (e.g. coal or wood) it must be swept prior to this installation proceeding.

This type of installation will use the top exit flue. The appliance is configured for this type of installation when unpacked from the carton. A 127mm (5") single skin flue pipe should be used to connect the appliance to a register plate. A 127mm (5") or 178mm (7") liner can be installed and should run the entire height of the chimney. This liner (if fitted) must extend from the appliance to the flue terminal.

Alternatively, the flue gases can vent using the existing chimney, providing the debris diverter is fitted to the top of the flue pipe. See adjacent diagram.

Note: it is important that an access hatch is provided in the register plate to allow debris removal.

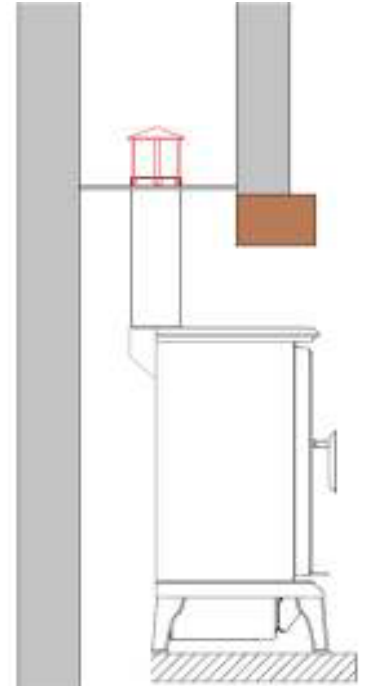

REAR FLUE SITE REQUIREMENTS

3.4.0.2 If the appliance is to be installed with a rear flue exit, the product must first be configured for this type of installation. Refer to page 21 in these instructions to convert the appliance to rear flue.

For this type of installation, the rear flue kit must be purchased separately. It is important that the rectangular flue duct protrudes at least 15mm through the closure plate. This duct should be cut to size during the installation process. This duct cannot be extended. The free end of this duct should ideally be positioned directly beneath the centre line of the flue way. It is important that at least 50mm of free area past the flue duct is left to allow the combustion products to clear easily.

Ensure that 50mm is left between the rear of the appliance and the closure plate.

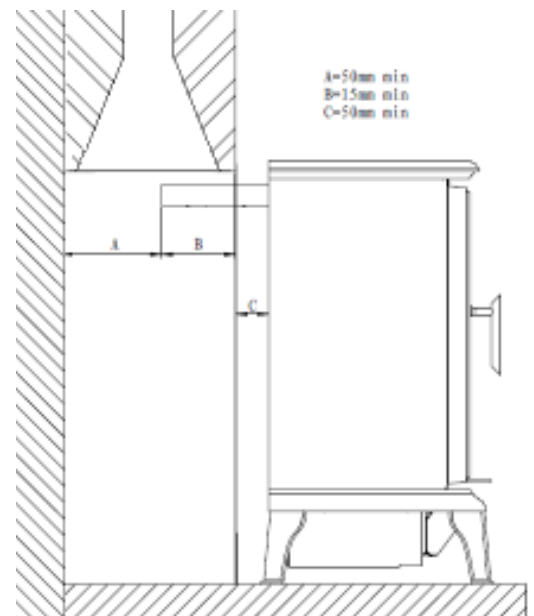

Hearth

3.4.1 This appliance must stand on a non combustible hearth with a minimum thickness of 12mm. The hearth must protrude a minimum of 50mm to the left and to right of the appliance and at least 150mm in front of the appliance.

Building regulations do allow for a minimum of 50mm protrusion for each of these dimensions, however we recommend the values stated above to provide a reasonable physical boundary from the appliance due to high temperatures of working surfaces, such as the glass panel.

Check The Flue

3.4.2 Use a smoke pellet prior to the appliance installation to ensure the viability of the flue and check that the smoke can be seen being emitted from the terminal / chimney pot outside. There must be no leakage of smoke through the structure of the chimney/flue during or after the smoke pellet test and it is important to check inside upstairs rooms adjacent to the chimney / flue. Check the chimney pot / terminal and general condition of the brickwork or masonry. If the chimney or flue is in poor condition or if there is no up-draught do not proceed with the installation. If there is a history of down-draught conditions with the chimney / flue, the installation of a tested and certificated flue terminal or cowl suitable for the relevant flue type should be considered.

Appliance Dimensions

3.4.3 The following drawing shows the appliance dimensions. Note: if calculating chamber sizes and minimum clearances regarding side clearances shown on the next page, appliance width should be taken as 436mm

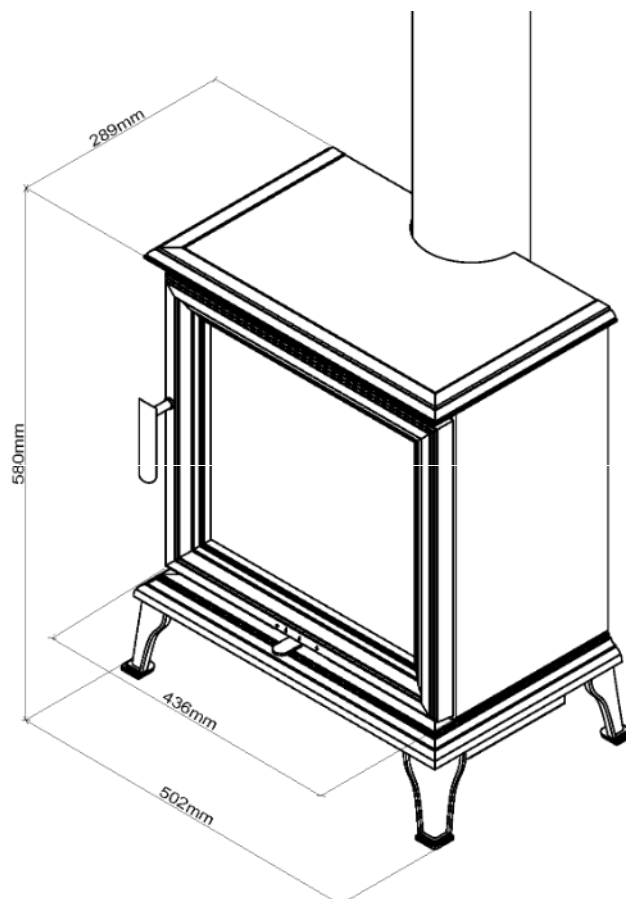

Clearances

3.4.4 The following drawings show the recommended **fireplace openings** required from combustibles and non combustibles for installation.

Combustibles

This drawing shows the minimum clearances from combustible materials. A minimum clearance of 50mm must be left at the rear of the appliance (from the back vertical face). The rear wall must not be made from combustible materials, this wall **must** be non combustible.

IMPORTANT NOTE:

The register plate, or top panel of the chamber **MUST** be non combustible. The 150mm dimension shown on this diagram pertains to combustible mantels or beams level or in front of the appliance.

This 150mm clearance is satisfactory for mantels sitting up to 75mm in front of the appliance glass. If this shelf/mantel/beam projects further than 75mm from the glass face then the clearance must be increased by a similar amount.

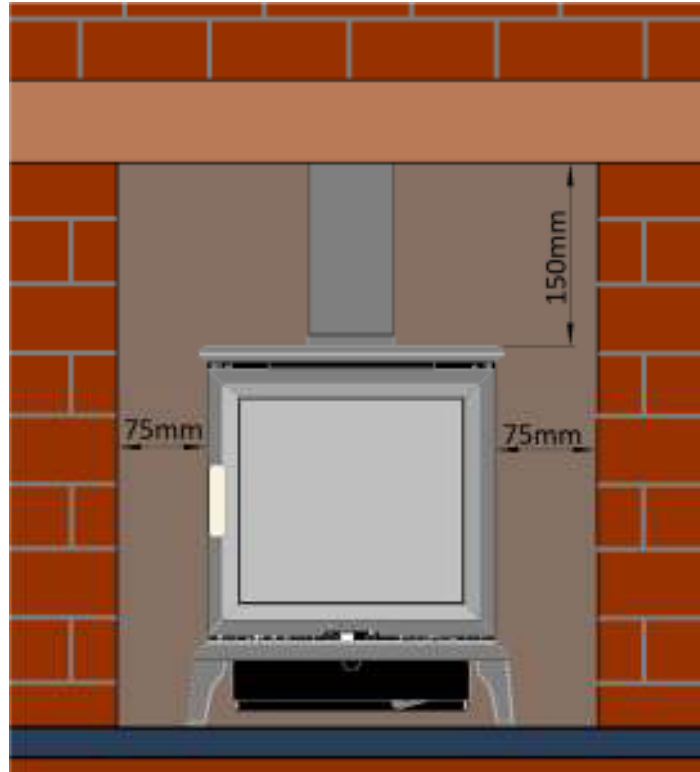

For example, shelf projection = 100mm
Clearance must be 175mm (to the shelves nearest point).

Non Combustibles

This drawing shows the minimum clearances from non combustible materials. A minimum clearance of 50mm must be left at the rear of the appliance (from the back vertical face). The rear wall must not be made from combustible materials, this wall must be non combustible.

It is recommended that the side wall clearance is made larger if possible as this will allow more airflow to and around the appliance.

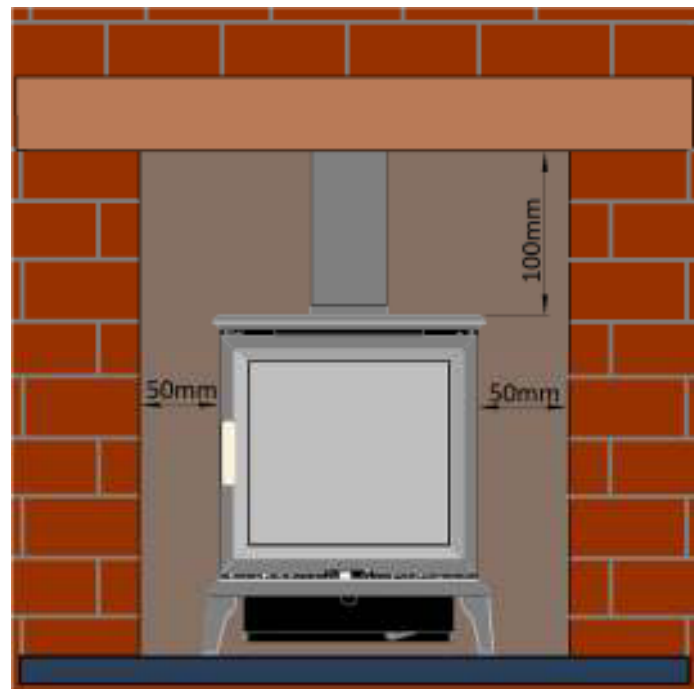

Back Panel

3.4.5 If the appliance is being fitted using the rear flue option, the closure plate can be used to seal either a 16" x 22" opening or a 12" x 22" opening (precast) The back panel should be produced from **non combustible** material and be smooth and flat to allow adhesion of the closure plate to its surface.

Debris

3.4.6 Debris should be removed during every annual service. In the case of rear vent installations, the closure plate should be removed and debris removed. This may not be necessary for precast flue installations as very little debris will be accumulate. In the case of top flue installations, the register plate access hatch should be removed and all debris removed. It is advisable that during this process the debris guard fitted to the top of the flue pipe (if applicable) should be checked for debris blockage or damage and replaced if necessary.

Ventilation

3.5 No purpose made ventilation is required for this product as the nominal input does not exceed 7.0 kW, however if spillage is detected during the installation commissioning it may be necessary to provide some additional ventilation. Always check the current rules in force for the country of installation.

Gas Supply

3.6 This appliance is suitable for use on natural gas (G20) only from a governed meter. It is the responsibility of the installer to ensure that correct pipe sizing has been supplied to the site for correct performance. 8mm diameter ductile copper tubing should be used for the run to the appliance at a maximum length of 500mm to avoid pressure drops. The appliance is supplied with a restriction device which must be used as part of the installation. There should be no soldered joints within the firebox of the appliance.

Rear Flue
(Optional)

3.7 This appliance can be installed with a rear flue outlet. The product is supplied in a configuration for top flue installation and therefore must be modified as shown in the following diagrams if rear flue system is to be used.

Step 1.

Remove the four screws shown to allow the top cover to be removed.

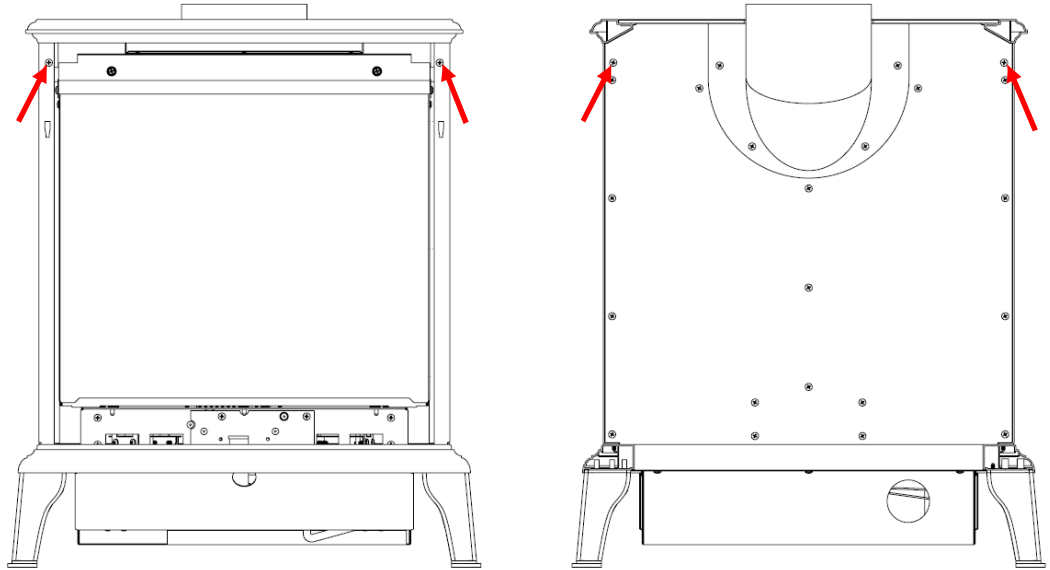

Step 2.

Remove the four screws as shown

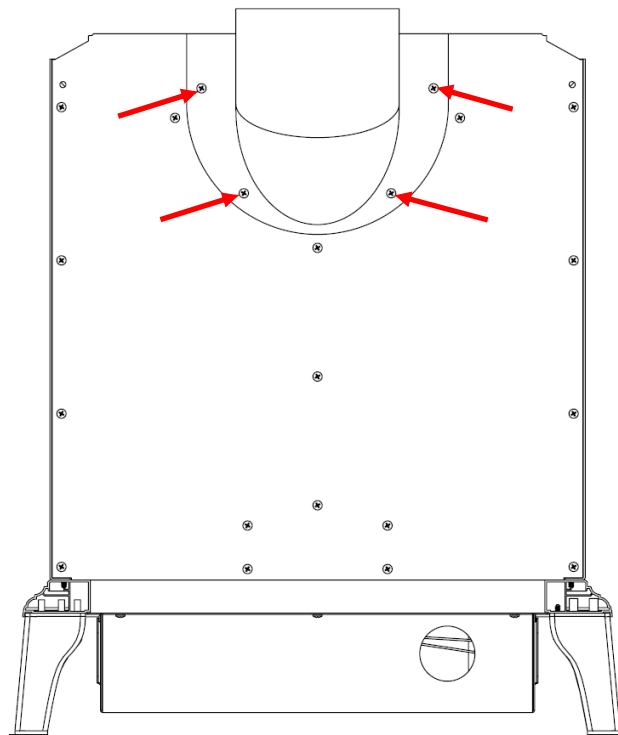

Rear Flue
(Continued)

Step 3.
Remove the four screws to allow removal of the top flue outlet.

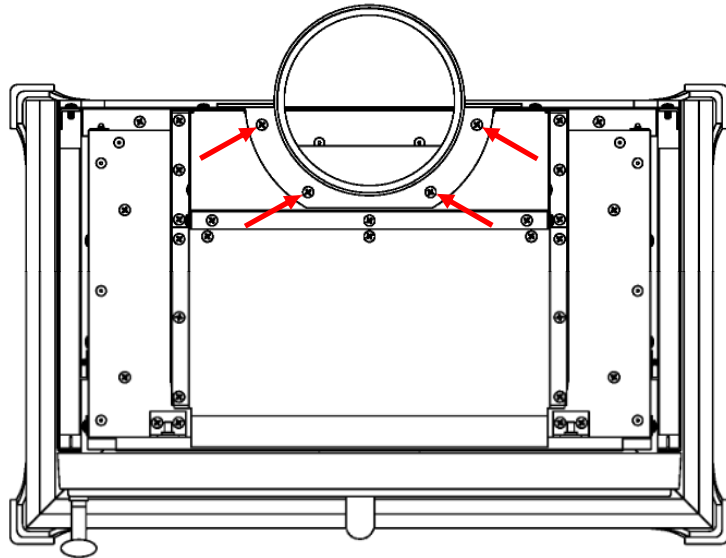

Step 4.
Fit the ceramic gasket using the four screws provided in the rear flue kit. Then using 5 screws, attach the rear rectangular flue duct as shown.

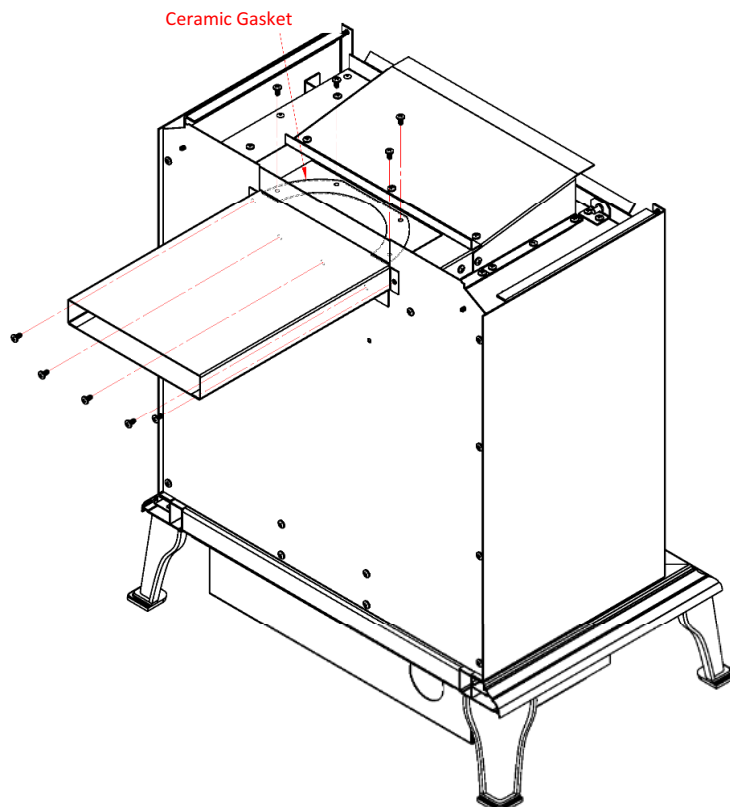

Rear Flue
(Continued)

Step 5.

Fit the top flue blanking plate as shown.

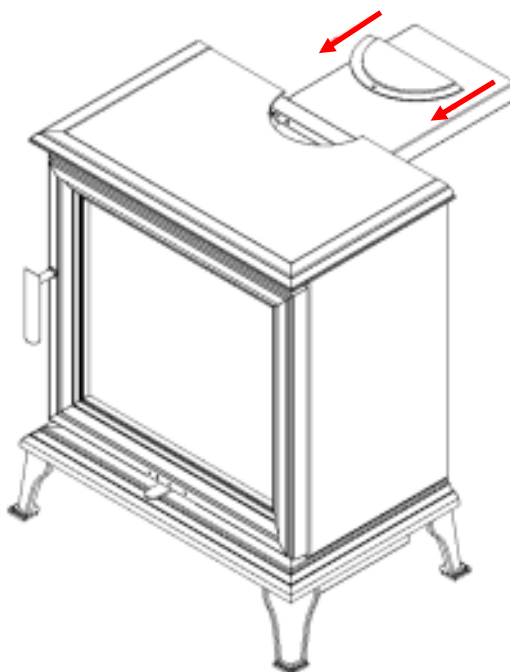

Step 6.

The appliance is now ready for rear flue installation. Check flue duct dimensions and installation on page 17.

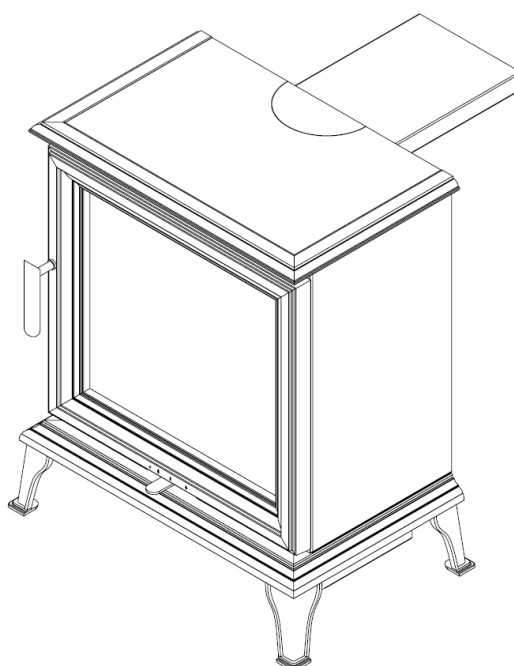

Connecting
to Gas Supply

4.2 Connecting the Appliance to the Gas Supply

The gas supply should be connected to the appliance by a concealed fitting from the rear. In all installation conditions the gas connection should be provided using 8mm (O/D) copper tubing. **No soldered joints** should be used with the firebox of the appliance.

Before connecting the gas supply to the appliance the supply should be purged to ensure no debris can enter the appliance and a gas soundness test should be performed to ensure that the existing pipe work in the property is sound.

The following diagrams show the access to the inlet gas pipe where the isolation valve will be fitted.

If the burner tray needs to be removed, see full details on pages 34.

The gas connection should be made to the appliance by the 8mm restrictor isolation valve supplied with the appliance. See the diagram below. This restrictor elbow is supplied loose and should be fitted as per the label on the instruction packet.

Test the operating pressure of the appliance by attaching a pressure gauge to the test point of the appliance. This connection should take place when the appliance is OFF. Ensure that gas is turned on at the gas meter.

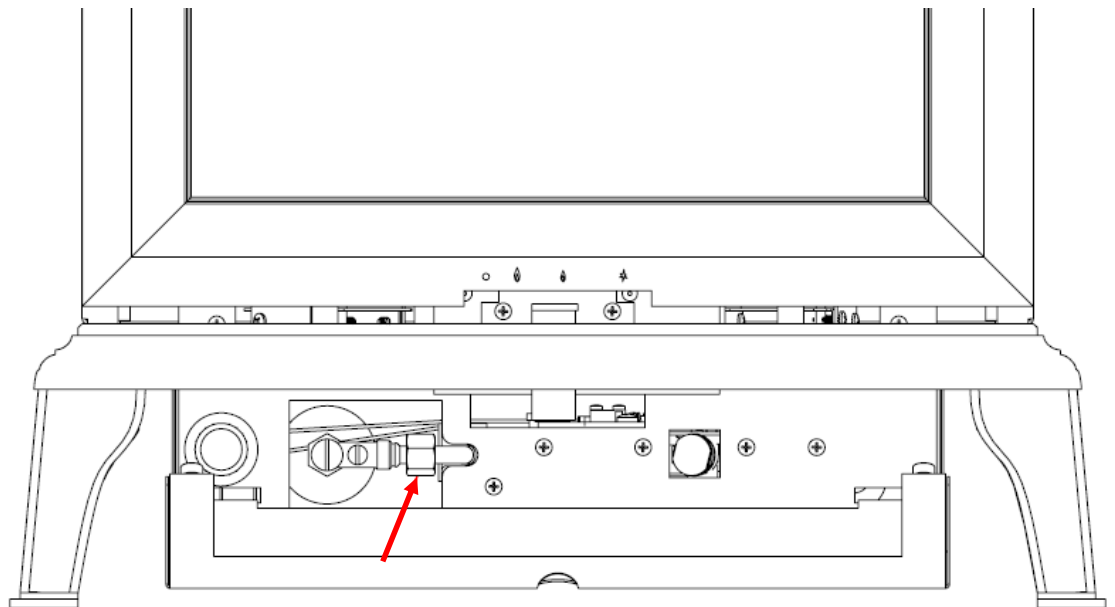

LOG SETUP

4.3 The following instructions detail how the ceramic fuel bed and loose components are to be installed onto the appliance. Great care should be taken when handling these ceramic parts as they are fragile and can easily be broken. Do not force any component into position, if it does not fit easily then you are not fitting the part correctly. These instructions can also be followed to remove or reinstall the fuel bed after cleaning. This is a procedure that can be undertaken by the customer as required and the frequency will be depend upon use.

See page 6 for glass door removal and installation.

The fuel bed setup involves the installation of volcanic rock, ceramic bark, ember wire and a boxed set of ceramic decorative logs. These components will have been installed by your gas engineer at the point of installation, however it is permitted for the end user to remove clean and replace these components as necessary. The following installation instructions must be adhered to at all times.

The following diagram is for identification purposes. It is imperative that the logs are placed in the correct position for safety and also to ensure that you obtain optimal performance from your appliance.

IDENTIFY

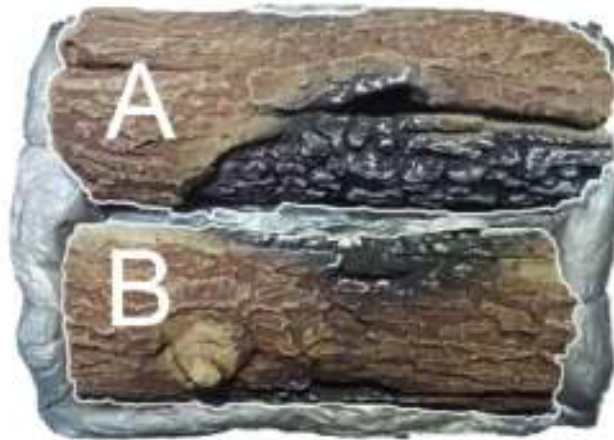

FUELBED

Place the volcanic rock on top of the centre burner as shown. Ensure a 4-5 mm gap is left between each piece. Then using **half** of the glowing ember wire supplied (Tools & Fittings Pack), ruffle between fingers to make it loose and about 20mm wide then align over the volcanic rock as shown. Ensure no wire is placed within 25mm of the pilot assembly. Retain the other half of the wire for replacement at annual service.



Place Log D as shown in the picture.



Place Log C as shown in the picture.



Place Log E as shown in the picture.



Place Log A as shown in the picture.



bark

Place Log B as shown in the picture.



Place Log H onto the burner bed as shown.



Place Log I onto the burner bed as shown.



LIGHTING THE FIRE

4.4 Operating Instructions

This appliance is operated using a slide control lever.

The knob will slide from left to right, this movement controls all functionality of the appliance, from ignition, flame control and turning the appliance off.

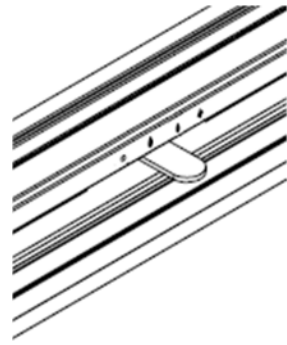

Slide the control knob to the right to the ignition symbol. After a few seconds the pilot light should light.



If the pilot light does not light, release the control knob and wait for 3 minutes before reattempting. If the pilot does not light after 3 attempts, check the battery—see page 6. If the battery is new and the pilot still fails to light, check the spark at the pilot.



Once the pilot is lit, keep the lever pushed to the right for up to 10 seconds then release. The pilot should stay lit and the central and front log burners will now light. The appliance is now running at the LOW setting.



Slide the knob slowly to the left to turn the rear log burners on. The appliance is now running at the HIGH setting.



To turn the fire off, slide the lever all the way to the left to the OFF symbol.



Should the spark generator fail to provide a spark at the electrode it may be that a small amount of soot has fallen from the fuel bed onto the pilot assembly, causing a short circuit. If this is the case, ensuring the appliance is off and cold, this area can be cleaned with the thin nozzle from a vacuum cleaner. See page 6 for details on glass removal to access this area.

Alternatively check the battery is in good condition—see page 6 for details.

Check for spillage

4.5 Spillage monitoring System (ODS Pilot)

This appliance is fitted with an atmospheric sensing system in the form of an oxygen sensing pilot burner. This is designed to shut the fire off in the event of products being spilled into the room where the fire is being operated. It is important to note that this spillage monitoring device should not be disabled or be adjusted by the installer. If the spillage monitoring device (O.D.S pilot) is replaced it must only be exchanged with a suitable component which is supplied by Hearth Products Ltd.

Check the clearance of combustion products

SPILLAGE TEST: To check for satisfactory clearance of products of combustion, close all doors and windows and leave the appliance burning on HIGH for five minutes. Using a smoke match holder, insert the smoke match about 50mm into the gap at the top centre of the stove. Traverse the match across the length of the draft diverter. All the smoke must be drawn into the flue. If spillage occurs allow a further 5 minutes and repeat the test.

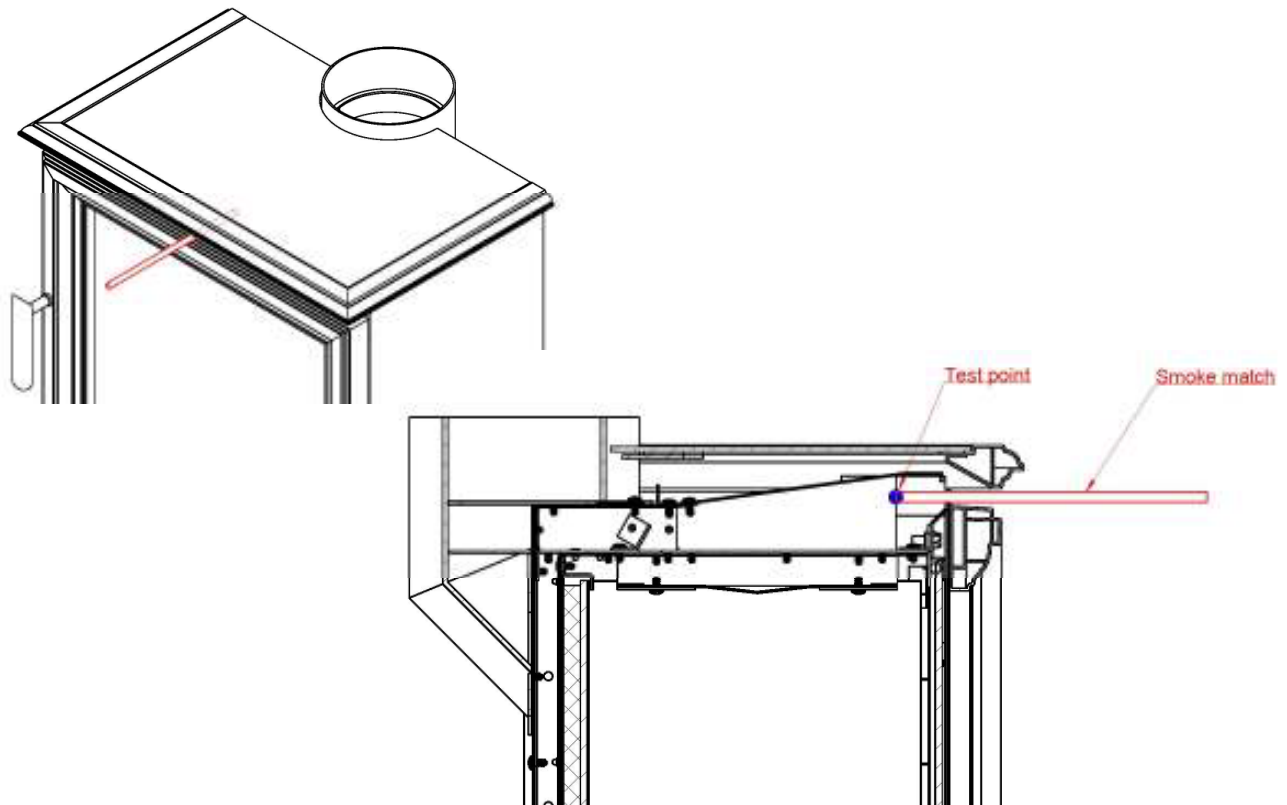

If the appliance fails the spillage test it may be necessary to install a 5" flue liner for the full length of the flue (if not already fitted). If the unit continues to fail this test, turn off the appliance and seek expert advice to expert advice.

If an extractor fan is situated in the room the spillage test should be repeated with the fan running. If there is a connecting room with an extractor fan the test should be repeated with all the doors to that room open and the extractor fan running.

Complete the
installation

4.6 INFORM THE CUSTOMER OF THE FOLLOWING TO COMPLETE THE INSTALLATION

Demonstrate the lighting of the appliance and the controls to control the heat settings.

Demonstrate how to turn the fire off.

Demonstrate the removal of the door frame and how to reinstall correctly.

Discuss the removal and reinstallation of the glass door and the ceramics. Explain how they should be cleaned and make the customer aware of the health and safety warning detailed in these instructions.

Explain to the customer that the ceramics are fragile and must be treated with great care, explain that the ceramics are not covered by the warranty because of their fragility. Also explain that small hairline cracks will appear in the surface of the ceramics due to heat expansion and contraction—this is perfectly normal.

During the first several hours of use an odour will be experienced—this is normal and is the starch, oils and paints used in the manufacturing process. This odour is non toxic and will eventually disappear with use.

Advise the customer that ALL glass fronted gas appliances will leave condensation on the inside face of the glass when first lit—this is perfectly normal and is a result of the water vapour present in the combustion products hitting the cold glass surface. This condensate will disappear over the next minute or so. It is also important to advise the customer that this condensate will carry with it any **impurities in the air** and will therefore, with use, leave a **slight grey condensation mark** on the inside of the glass. We advise that this is cleaned off maybe 2 to 3 times a year, dependant on use.

Advise that no rubbish should be thrown onto the appliance and that the appliance should be cleaned regularly.

Advise the customer that the appliance should be serviced annually by a gas safe engineer to ensure the safety and integrity of the appliance.

Advise the customer that the appliance has a naked flame and therefore it is essential that a suitable fireguard be used for the protection of the elderly, infirm and young children. This fireguard should conform to BS8423 : 2002 (Fireguards or use with Gas Heating Appliances).

These instructions and all supplied installation tools must be handed over to the customer once installation is complete.

Servicing

5.0 Servicing the Appliance.

The following procedures can and should **only** be performed by a **Gas Safe registered installer**.

This appliance should be serviced annually by a **Gas Safe registered installer**.



Isolate the appliance using the restrictor elbow and remove the 8mm nut from the restrictor as detailed below.

ALL SERVICE WORK WILL REQUIRE THE REMOVAL OF THE LOWER ACCESS DOOR, THE DOOR FRAME AND GLASS.

5.1 Removal of the Lower Access Door

Lower the access door as shown below then slowly pull the door out—it will release from the tray assembly.

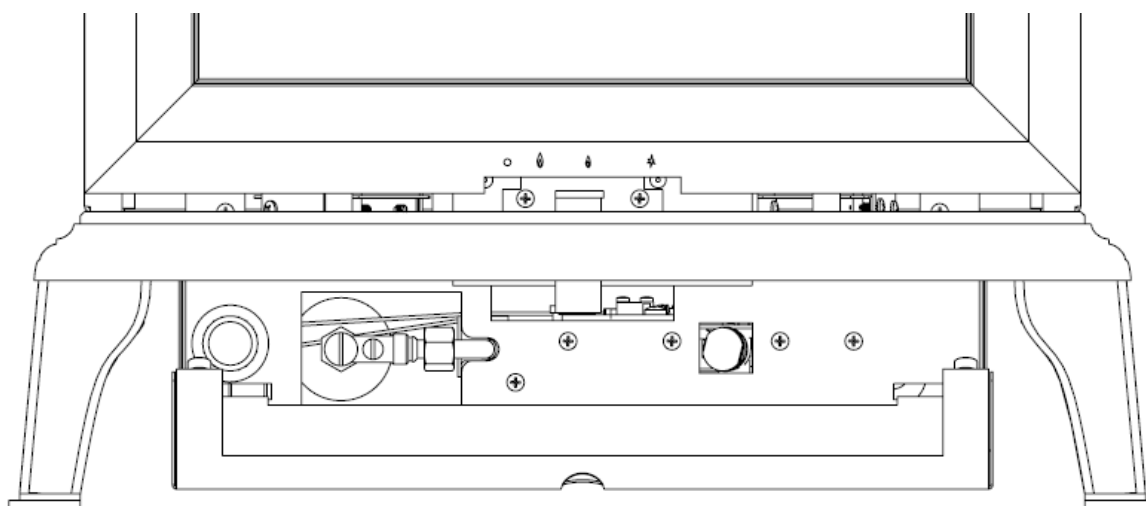

5.1 Removal of the burner tray.

Remove the two screws holding the lower glass retainer bar as shown in the first diagram.

The removal and replacement of all the gas carrying components will require the removal of the burner tray. The following information details the removal of this tray. Once removed, refer to the relevant section that follows detailing the removal of the specific component (s).

- Ensure the appliance is off and cold.
- Ensure that the gas supply is isolated by the restrictor valve on the appliance.
- Remove the fuel effect components - put in a suitable location where they cannot be damaged.
- Remove the 4 (four) screws securing the burner tray to the firebox. (See below)
- Carefully lift the burner tray through the front of the stove.
- Re-assemble the tray in the reverse order.

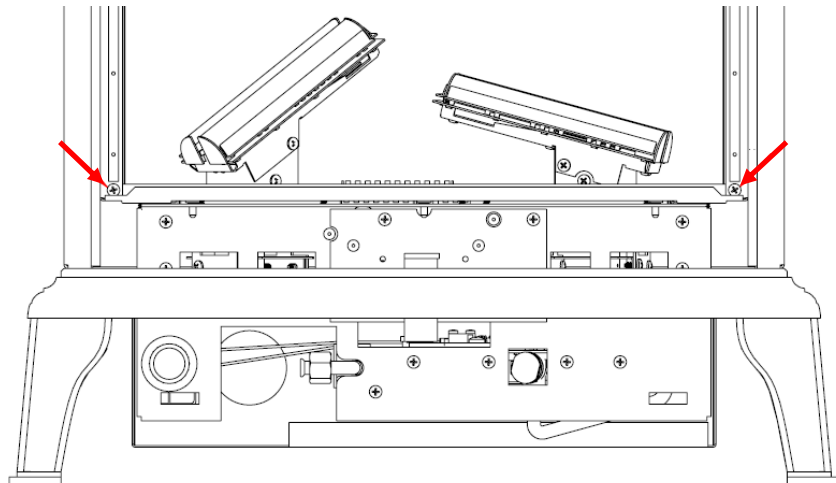

The following diagrams demonstrate the removal of the tray.

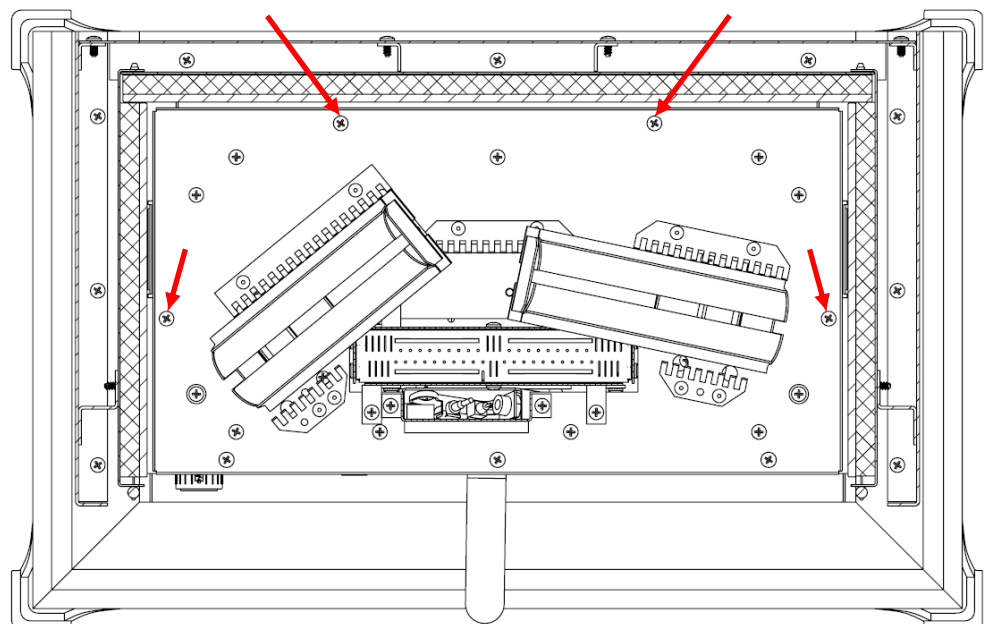

5.2 Removal of the pilot.

After the removal of the burner tray, first remove the two screws which secure the pilot access cover as shown below.

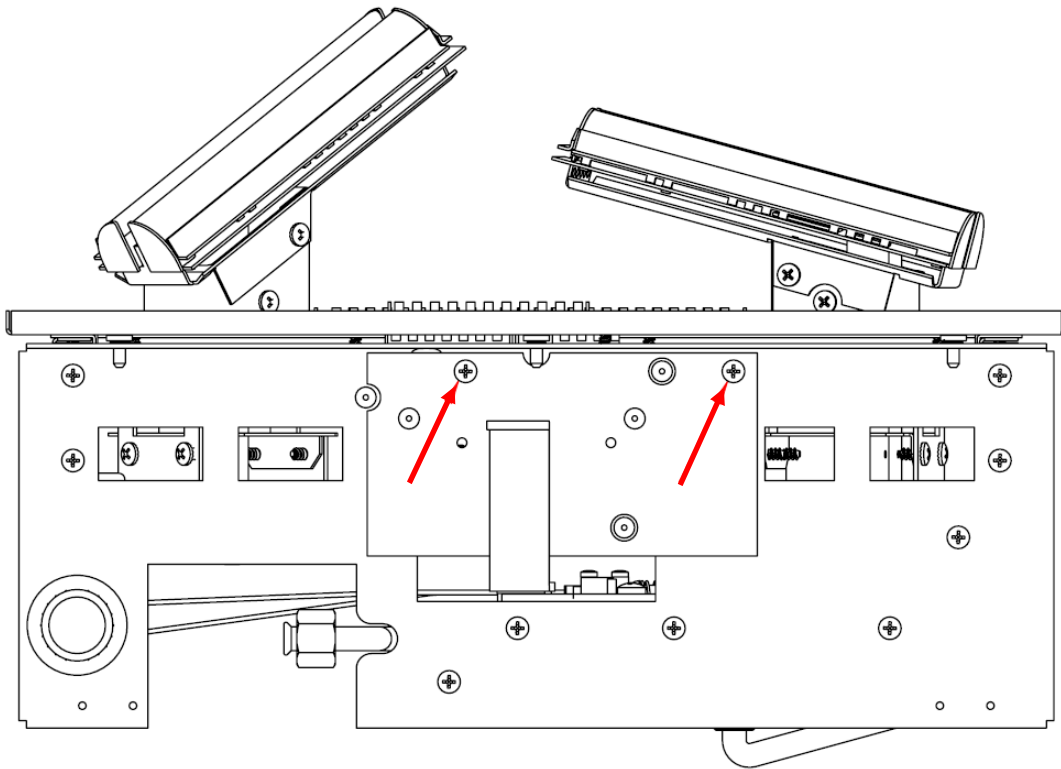

Now remove the HT lead from the base of the spark electrode and remove the two screws to release the pilot. Unscrew the gas inlet nut as shown in the diagram below.

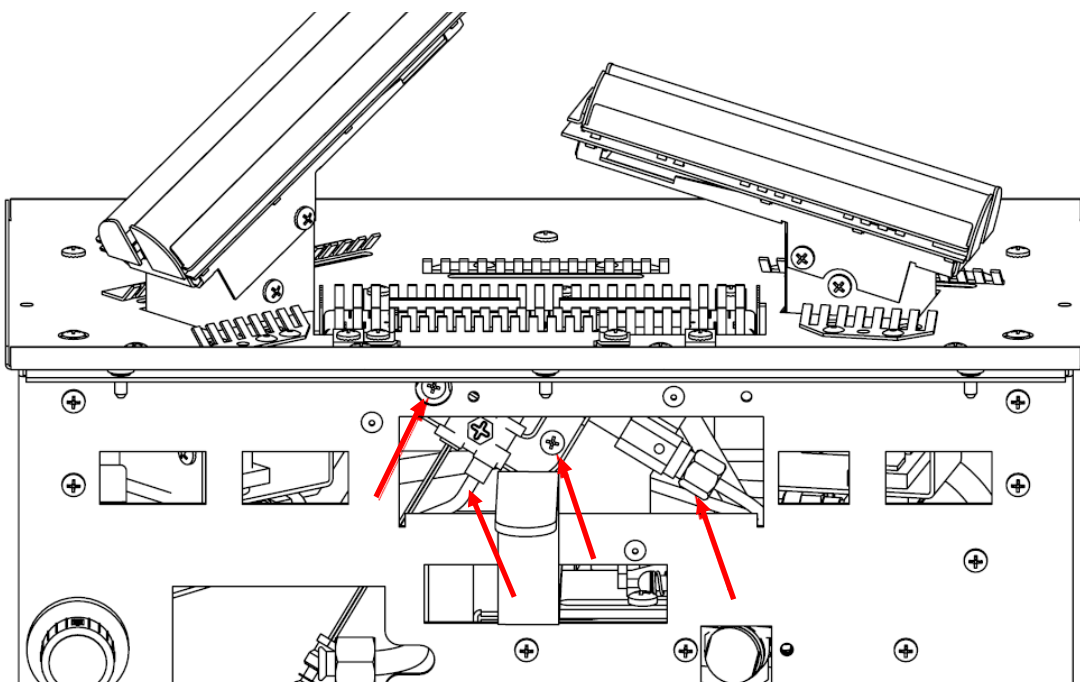

Now remove the thermocouple for the back of the slide valve and then remove the two small screws securing the microswitch to the underside of the burner tray.

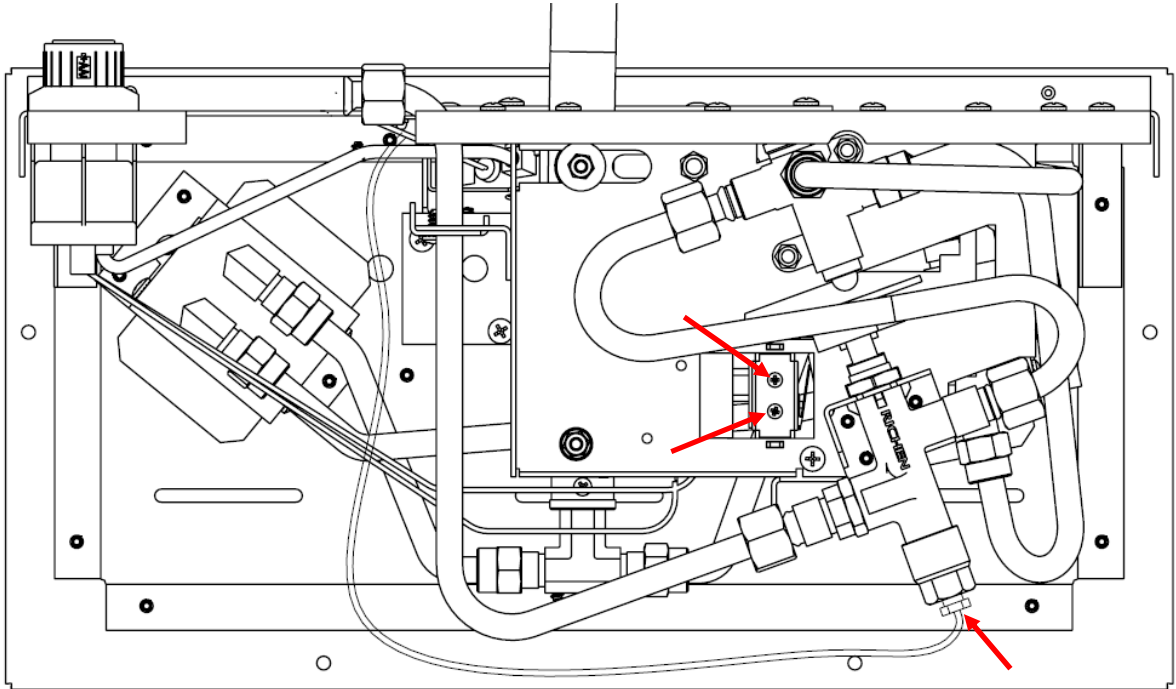

5.3 Remove of Slide Gas Valve.

Release the gas inlet, main burner outlet and pilot outlet nuts from the slide valve.

Then remove the thermocouple from the back of the valve. Unscrew the clamping nut from the front of the valve (see lower diagram) . **Whilst holding the operating control lever in the OFF position**, the valve can be carefully manipulated from the burner tray.

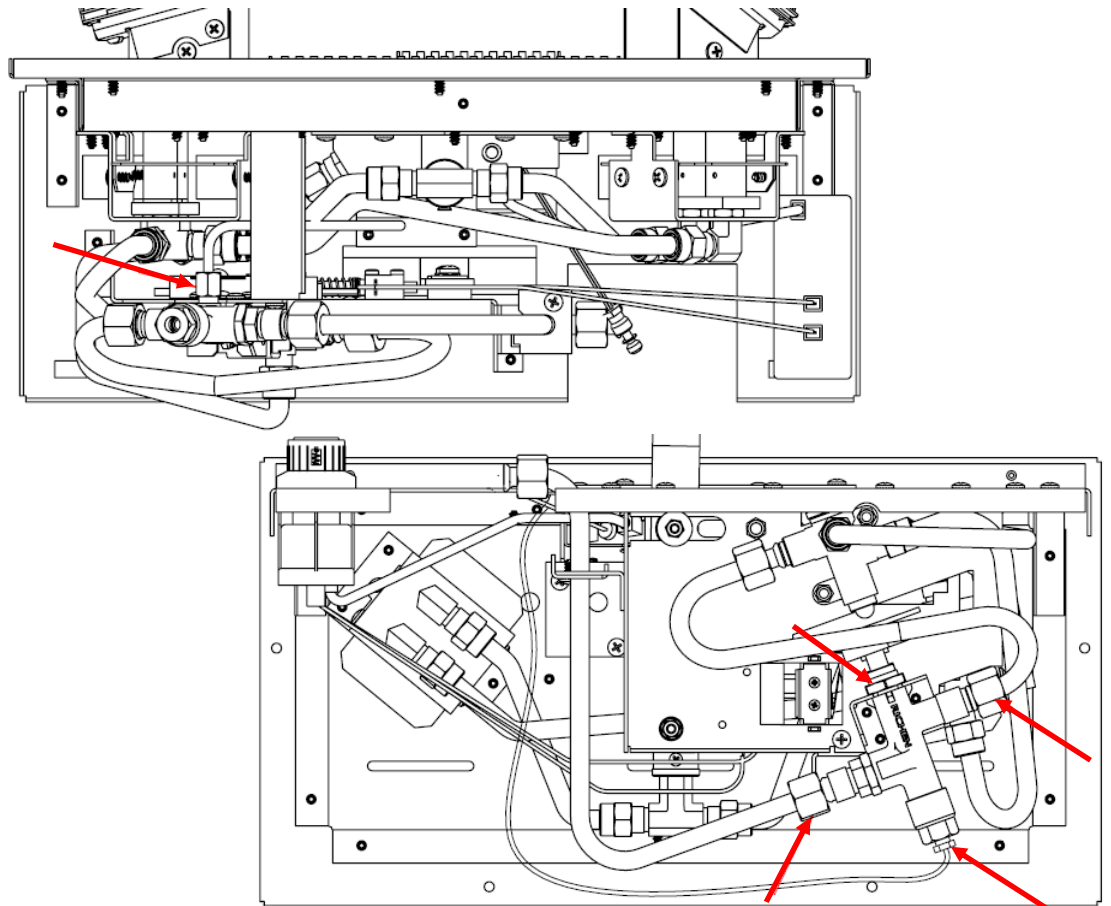

Remove the lock nut to release the valve.

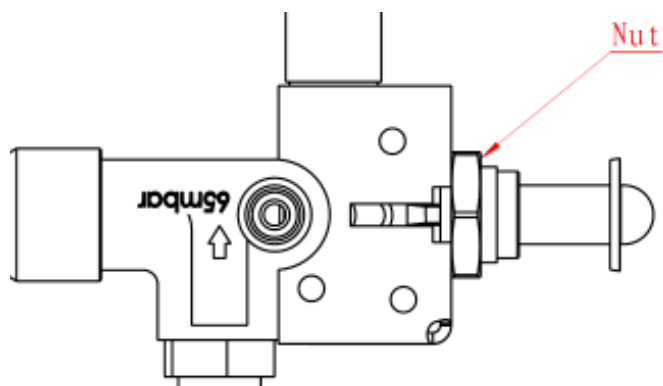

5.4 Remove of spark generator.

This service work will not require removal of the burner tray, the door frame or the glass.

Remove the battery cap, then unscrew the large nut securing the spark generator to the tray. Then remove the spark generator from the tray.

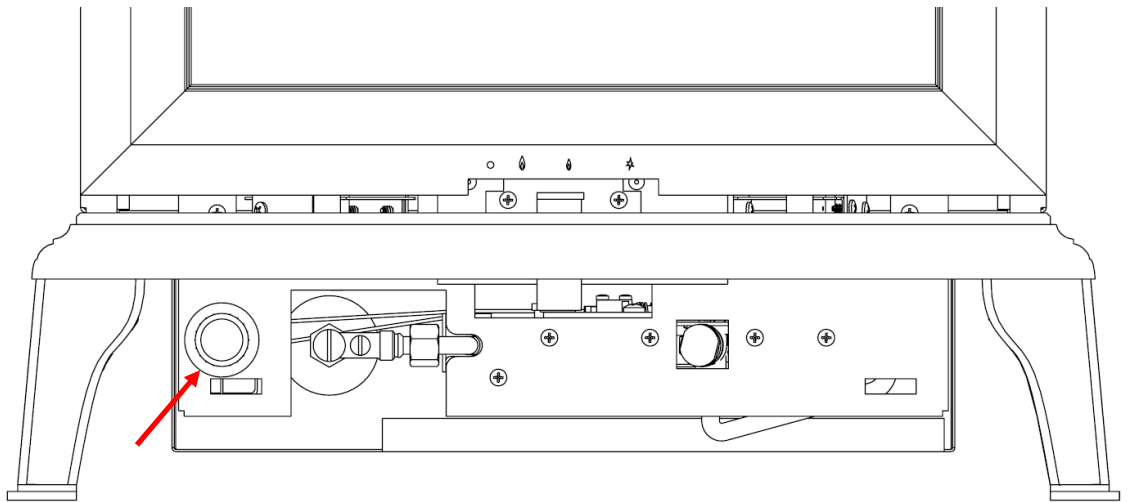

Detach the three wires (microswitch and HT lead) from the spark generator. The spark generator can now be removed.

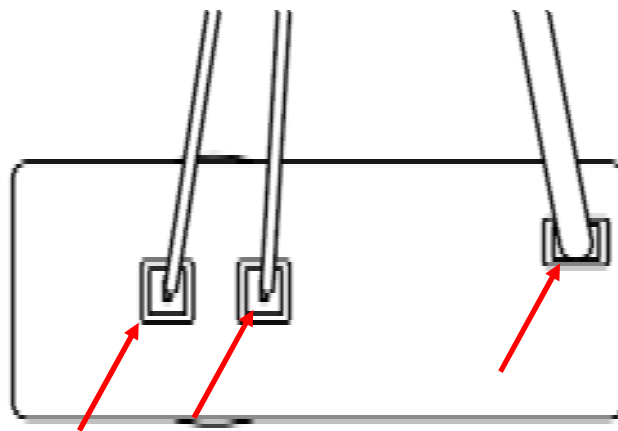

5.5 Removal of Tee Valve (High Setting).

Remove the 3 (three) gas connections from the Tee Valve as shown below.

Now remove the 2 (two) nuts securing the Tee Valve as shown in the diagram below.

The Tee Valve can now be removed.

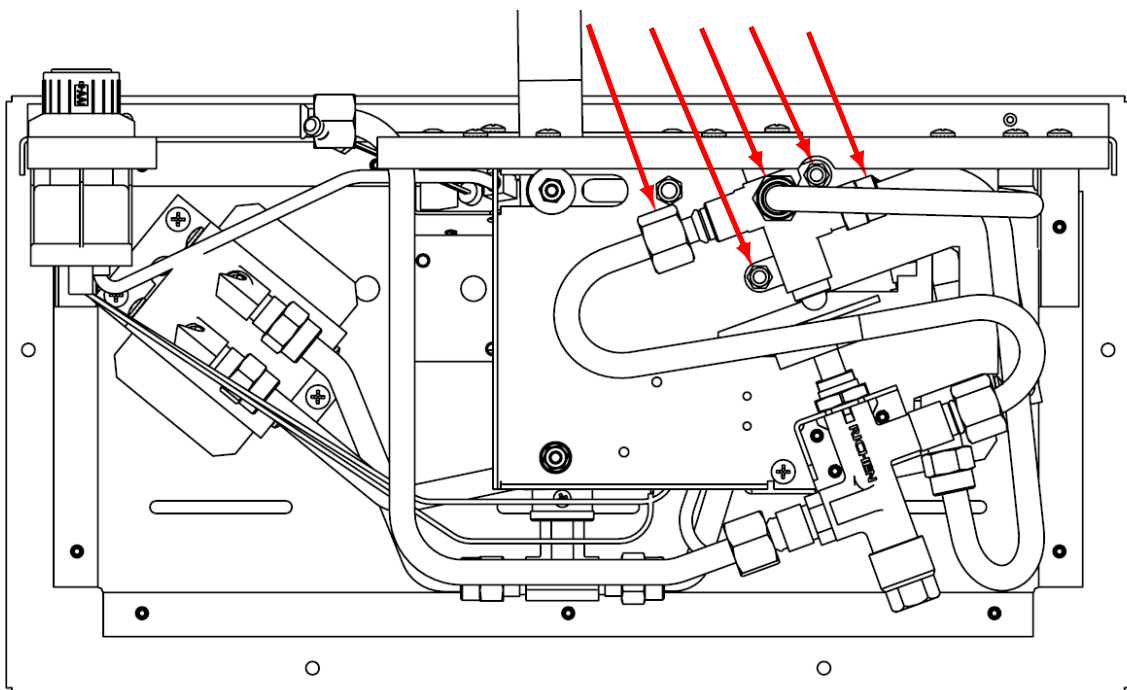

5.6 Removal of Injectors

Remove the 8 screws (4 each side) as shown in the diagram. The two raised burners can now be removed.

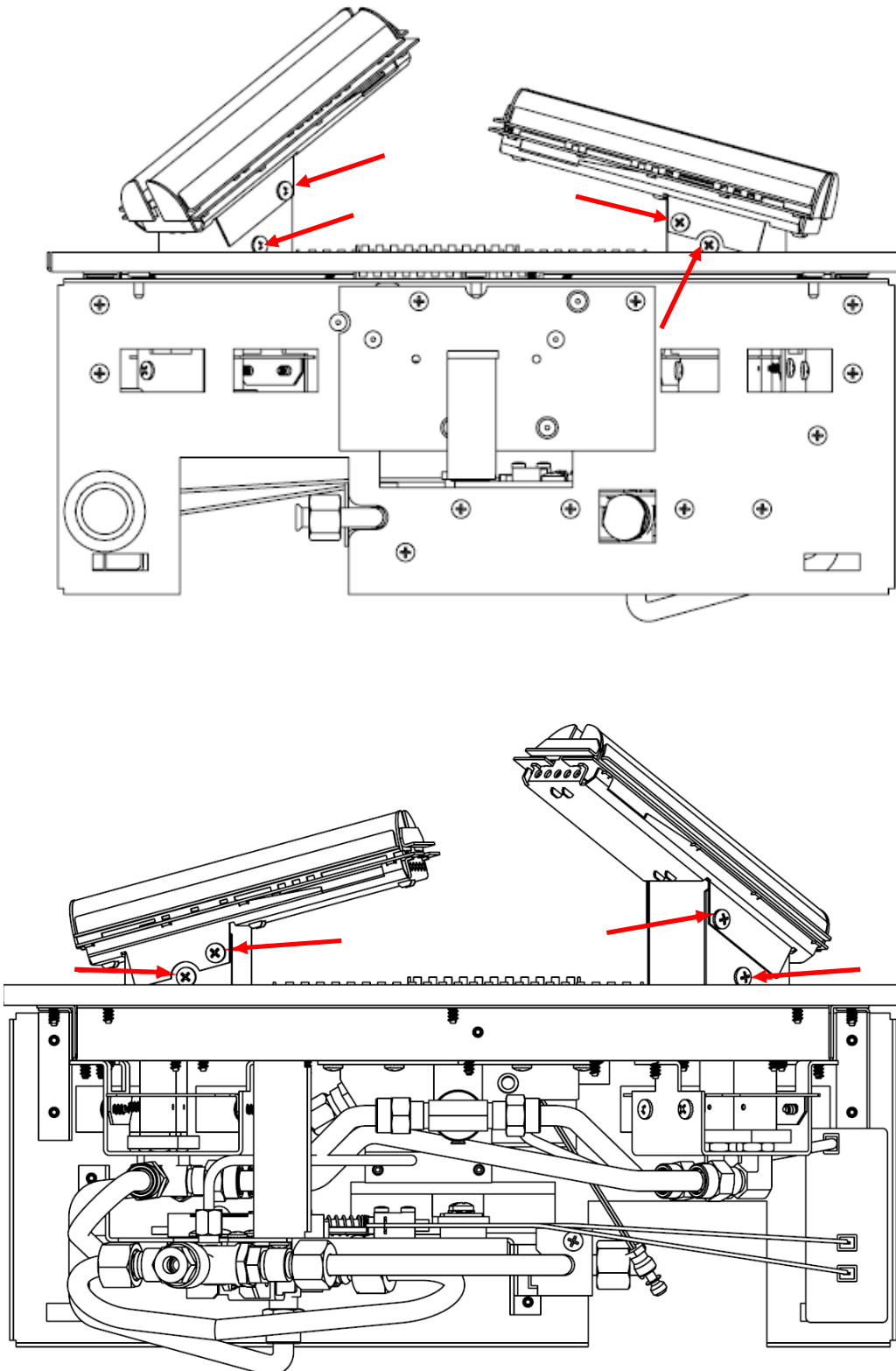

Removal of Injector. Continued

The 4 #71 injectors can be accessed using the socket drive.

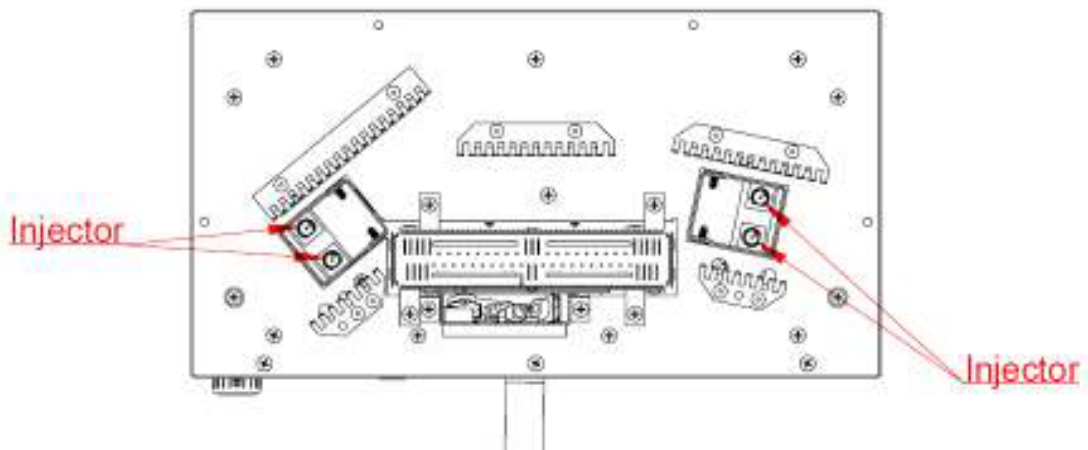

Finally remove the screw as shown below, The tee connector can be pulled out and the middle burner injector can be removed. This injector is marked 71.

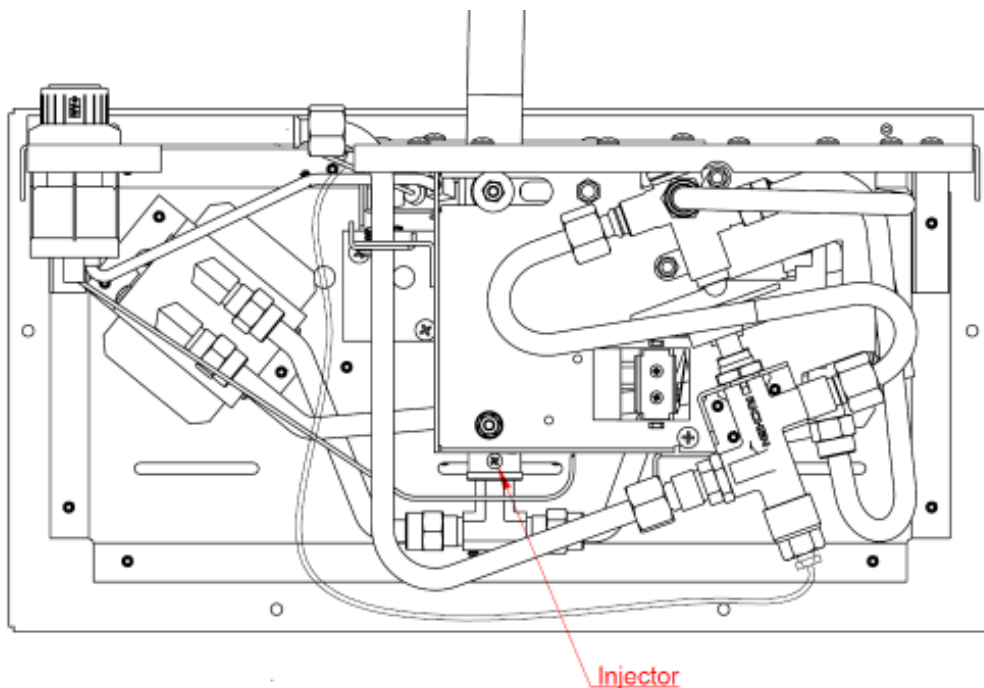

6.0 Record of annual services

The extended warranty of the specified components within this appliance is conditional on the annual service of the appliance by a Gas Safe registered engineer. Failure to maintain the product or to use the product in away which is not intended will void the manufacturer's warranty.

Ensure a record is kept of the annual services conducted by the Gas Safe engineer in the table below.

Service of this appliance must only be conducted by a Gas Safe registered engineer.



Annual Service Record

YEAR 1	Gas Safe Engineer Name:	
	Gas Safe Engineer Registration No.:	
	Date of annual service:	
YEAR 2	Gas Safe Engineer Name:	
	Gas Safe Engineer Registration No.:	
	Date of annual service:	
YEAR 3	Gas Safe Engineer Name:	
	Gas Safe Engineer Registration No.:	
	Date of annual service:	
YEAR 4	Gas Safe Engineer Name:	
	Gas Safe Engineer Registration No.:	
	Date of annual service:	

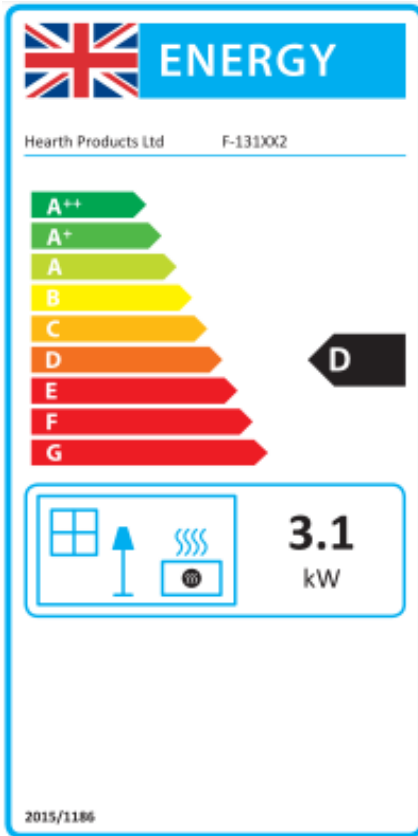

Product Fiche	
Manufacturer :	Hearth Products Ltd
Model No.	F-131XX2
Fuel Type	Natural Gas I2H
Energy Efficiency Class	D
Indirect Heating Functionality	No
Direct Heat Output kW	3.1kW
Indirect Heat Output kW	N/A
EEl	73.2%
Useful Energy Efficiency (NCV)	High : 82.2%
Useful Energy Efficiency (NCV)	N/A
Nominal Heat Output	High : 3.1kW
Nominal Heat Output	Low : 1.8kW
Heat Output Temperature Control	Two Manual Stages
Permanent Pilot Power (kW)	N/A
Space Heating Emissions NOx (GCV)	130mg/kWh

7.0 Important Note:

The energy efficiency class of this product is defined using a seasonal efficiency calculation which reduces the actual net efficiency of the product where the use of automated heat control, thermostats, window open sensors and timers are not used. This is not to be confused with the net efficiency, or useful efficiency of the appliance (shown in the tables above).

**This product MUST be installed by a Gas Safe Registered Installer. Full details are provided in this manual.
 Hearth Products Ltd. Unit 14 Tollgate Industrial Estate, Stafford, ST16 3SU**

User Replaceable Parts

Part Number	Description
P-XX1235	Ceramic Log Set
P-XX1212	Volcanic Rock Pack
P-XX1213	Ceramic Bark Pack
P-XX1234	Ember Wire Pack
P-XX140013B	Glass Panel (Front)

To order spare parts for your appliance visit www.hearthproducts.co.uk/spareshop or call us directly on 01785 225401

It is important to note that the above spares are user serviceable components that can be changed by the customer. The spares shop also features other components which may have to be installed by a Gas Safe engineer. If in doubt please contact us directly.



Hearth Products Ltd
Unit 14 Tollgate Industrial Estate,
Stafford, ST16 3SU

www.hearthproducts.co.uk

Tel: 01785 225401 Fax: 01785 225501

Email: info@hearthproducts.co.uk

UK UK
CA NI

Due to our policy of continual product improvement, some diagrams and small details may not be accurate however if there is any concern or matter of understanding that you feel needs to be clarified please contact us directly. Our contact details are shown below.