



BF960SL BALANCED FLUE ROOM SEALED GAS FIRE

USER INSTRUCTIONS

INSTALLATION INSTRUCTIONS

SERVICE INSTRUCTIONS

Do not use this appliance if the front glass panel is broken, removed or fitted incorrectly.

It is a regulation that these instructions be handed to the customer after installation is complete. It is also the responsibility of the installation engineer to ensure that the customer is able to fully operate the appliance and is aware of any cleaning or maintenance requirements.

Model numbers: F-111XX2 SLIDE for use on Natural Gas (G20) at a supply pressure of 20 mbar in GB /IE

(XX denotes trim type)

**THESE INSTRUCTIONS ARE TO BE LEFT WITH
THE CUSTOMER AFTER INSTALLATION**

CONTENTS

Regulatory Information and Installation Requirements	3
Regulatory requirements for Flue Terminal installation.....	4
Siting the Appliance	5
Preparing the appliance for installation	6
Opening the glass door	6
Removing the glass door	7
Remove the appliance form the outer box	8
Preparing the cavity wall	9
Preparing the Gas Supply	10
Installation into masonry cavity wall	11
Installation into studwork	13
Fit the horizontal flue section to the appliance	14
Record data plate information	14
Installing the appliance into the outer box	15
Connecting the appliance to the gas supply	15
Fitting the terminal	16
Connecting the terminal guard	17
Appliance Data Information.....	18
Fit the rear and side glass panels	18
Install the ceramics and refit the glass door assembly	19
Checking Operation of Appliance	20
Refit the outer trim	21
Important customer information	22
General Maintenance	23
Service Instructions	24
User Operating Instructions	30
Fuel Bed Layout Instructions	31
Appliance commissioning checklist	38
Product Fiche	39
Spare Parts List	40
Manufacturer's Contact Details	40

REGULATORY INFORMATION AND INSTALLATION REQUIREMENTS

THE FOLLOWING MUST BE NOTED PRIOR TO THE INSTALLATION OF THIS APPLIANCE.

This gas appliance **MUST** be installed by a GAS SAFE registered installer by law. It must be installed in accordance to these installation instructions and the GAS SAFETY (Installation & Use) REGULATIONS 1998 as amended. Non compliance of this law may lead to prosecution and it is in the interest of you and your family that this condition is observed.

The installation of this appliance must be in accordance with the relevant parts of the LOCAL AND NATIONAL BUILDING REGULATIONS as issued by the Department of the Environment or BUILDING STANDARD (Scotland Consolidation) REGULATIONS issued by the Scottish Development Department and the following relevant British Standards:

BS5871	Part 2 Installation of Inset Live Fuel Effect Gas Fires
BS5440	Parts 1 & 2 Installation of Flues and Ventilation
BS6891	Installation of Gas Pipe-work
IS813:1996	Domestic Gas Installation (Republic of Ireland)

Prior to installation ensure that the gas supply is compatible with the appliance, this appliance must only be used on **natural gas** at a supply pressure of 20 mbar as marked on the data plate on the appliance and the carton. **Modification to alternative gas types is not possible with this appliance.**

If the product is being installed into a timber framed building then advice should be sought specifically as building alterations may void any cover supplied by NHBC. If in doubt contact your local building and planning authority. Further information can be obtained from the publication: Gas Installations in Timber Frame Buildings : IGE/UP/7 Edition 2.

The efficiency of this appliance has been tested to EN613 and the result is 86% net (77.4% gross). This efficiency value has been verified by Kiwa (0558). This efficiency value can be used for SAP (Standard Assessment Procedure) for energy rating of UK dwellings.

Ventilation

No purpose made ventilation is required for this appliance.

This appliance must only be installed in accordance with BS5440: Part 1 and these installation instructions. For minimum and maximum flue dimensions refer to page 5 of these instructions. The horizontal flue section only should be modified by the installer to suit the installation, no modification should be made to the flue terminal. The guard (supplied) must be fitted to the terminal if any part of the terminal is below 2 metres above any accessible point, ie the ground or balcony etc.

Do not place soft wall coverings (i.e. embossed papers etc,) furniture or other combustible items too close to the appliance as they may discolour or scorch.

Do not place or throw rubbish or otherwise on the fuel-bed.

It is very important that you arrange for a GAS SAFE registered engineer to service your appliance every year – This is important for you and your families safety.

NEVER place more ceramic components onto the fuel bed than specified in the instructions.

NEVER touch the glass panel or metal parts surrounding the glass when the fire is running or if it has recently been in operation—these components retain heat and may cause burns. Leave the appliance to sufficiently cool prior to any contact.

WARNING: This appliance has very hot surfaces when in use and as with all heating appliances a fireguard should be used for the protection of children, the elderly, infirm and pets. The fireguard should conform to BS8423 : 2002 (Fireguards or use with Gas Heating Appliances).

Important Note: It is quite normal for a flame effect gas appliance to experience a small amount of soot or staining to some parts of the fuel effect components. If this becomes excessive it may be because the fuel bed is not fitted correctly—this should be checked according to these installation instructions prior to contacting a service engineer.

REGULATORY REQUIREMENTS FOR FLUE TERMINAL LOCATION

Figure 1

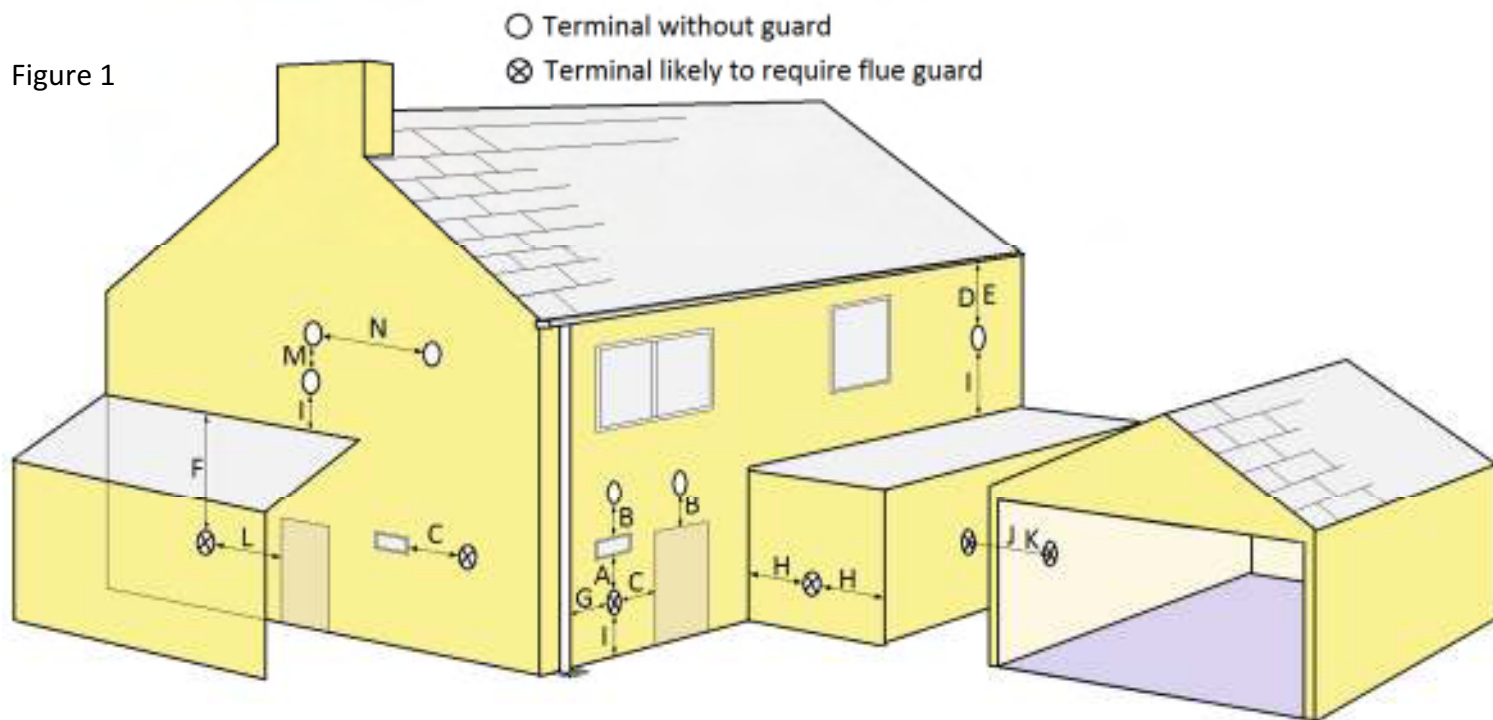

Key	Terminal Position	Minimum Distance
A*	Directly below an opening, airbrick, opening window etc.	300mm
B*	Above an opening, air brick, opening window etc.	300mm
C*	Horizontally to an opening, air brick opening window etc.	300mm
D	Below gutters, soil pipes or drains.	300mm
E	Below eaves.	300mm
F	Below balconies or car port roof.	600mm
G	From a vertical drain pipe or soil pipe.	300mm
H**	From an internal or external corner	600mm
I	Above ground, roof, or balcony level.	300mm
J	From a surface facing the terminal.	600mm
K	From a terminal facing a terminal	600mm
L	From an opening in a car port (e.g. door, window) into dwelling.	1200mm
M	Vertically from a terminal on the same wall.	1500mm
N	Horizontally from a terminal on the same wall.	300mm

* In addition, the terminal should not be nearer than 300mm to an opening in the building fabric formed for the purpose of accommodating a built-in element such as a window frame or door frame.

** The reference to external corners does not apply to building protrusions not exceeding 450mm, such as disused chimneys on external walls.

A terminal guard is supplied with this appliance. It is a requirement in England and Wales that this a guard be fitted where the flue terminal may come into contact with people near the building or be susceptible to damage.

In the republic of Ireland the installation must conform to the relevant sections of IS813 'Domestic Gas Installations'.

Hearth Products recommend that the terminal guide be fitted in any area where it may be damaged or contact could be made with the flue terminal.

SITING THE APPLIANCE AND PREPARING THE OPENING

Figure 2

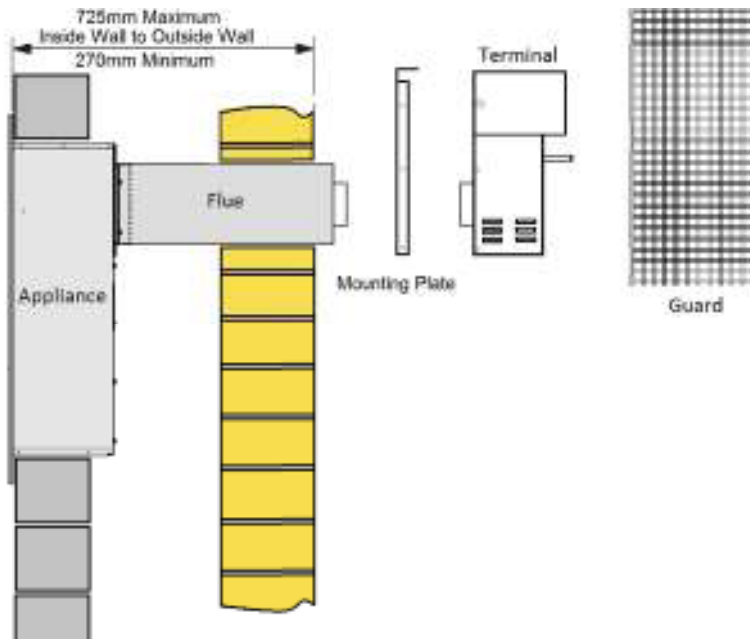

Figure 2 shows the maximum length flue attached to the appliance. If the distance from the front face of the inside wall to the outside wall exceeds 725mm the installation cannot proceed. In most installations the flue section will need to be cut to the appropriate size. Any reduction to flue length must be removed from the end opposite the terminal and the three holes then re-drilled to fix the flue to the appliance—use the holes in the waste section of flue as a guide.

DO NOT CUT THE FLUE YET. ONCE THE APPLIANCE CAN BE PLACED IN POSITION THE FLUE LENGTH CAN BE CHECKED BEFORE CUTTING—REPLACEMENT FLUES WILL BE CHARGED FOR IF THE FLUE IS CUT INCORRECTLY.

FLUE CUTTING INFORMATION IS ON PAGE 14 OF THESE INSTRUCTIONS

Figure 3 shows the appliance dimensions. This should be used to determine where the fire will be installed into the customers property. An area of 1500mm wide and approximately 1200mm high (from the intended base line of the appliance) - (see page 9) should be cleared of ALL combustibile material. Plasterboard in this area should also be removed— this will be replaced with a suitable heat resistant board. The flue hole must be 6" (minimum) diameter and located at a height of 523mm from the base line of the appliance.

A clearance of at least 5mm must remain between the rear face of the appliance and the inner face of the outer brickwork. Ensure there are no combustibile materials in this area.

Fig.3

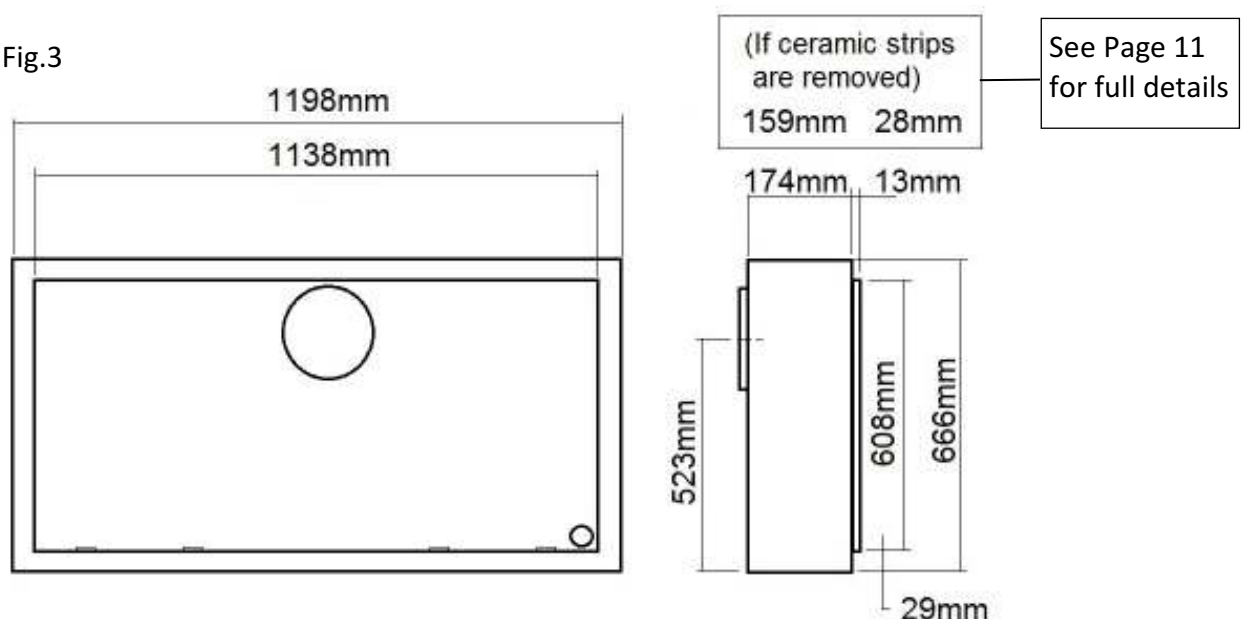

PREPARING THE APPLIANCE FOR INSTALLATION

Unpack the appliance carefully from the packaging. This product is supplied in TWO cartons. Ensure it is not damaged and that all of the components are included. The cartons should include:

- 1a Appliance and (Trim is fitted to the appliance) - See below for trim removal instructions.
- 1b Ceramic pack (Behind the glass) - See below for glass door opening instructions.
- 1c Tool and fitting pack—Includes 2 tools and seal grommet and fittings required for installation.
- 1d Rear and side glass panel pack
- 1e Instruction and Warranty pack.
- 2a Flue Pipe (Inner and Outer)
- 2b Terminal Mounting Plate
- 2c Terminal
- 2d Terminal Guard
- 2e Screw & Fittings Pack.

REMOVING THE TRIM & OUTER TRIM

DO NOT ATTEMPT TO REMOVE THE TRIM BEFORE READING THESE INSTRUCTIONS

The trim is securely fastened to the appliance and must be removed using a Philips headed screwdriver.

Using an appropriately sized Philips headed screwdriver, carefully unscrew the two screws visible between the gap between the trim the side of the glass door. Once these screws are removed the trim can be carefully pulled away from the appliance. **Put the trim in a safe place for the remainder of the installation to avoid causing damage.**

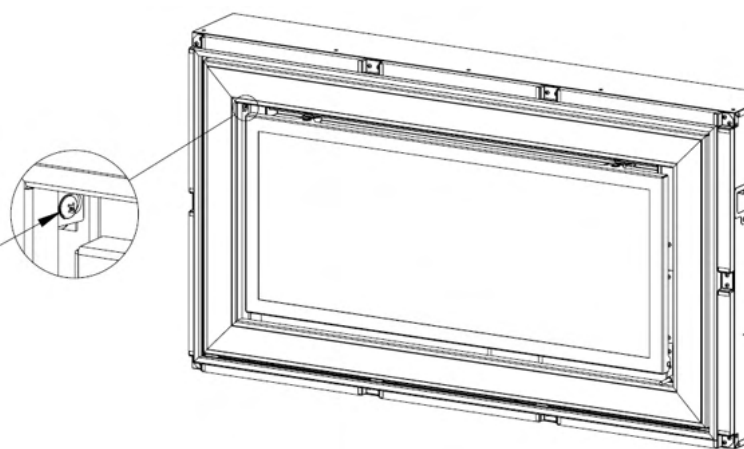

OPENING THE GLASS DOOR

Using the 90 degree short Allen key from the tool-pack, insert into the hex bolts at the top edge of the glass door. Rotate these bolts (one is top left, the other is top right) about a quarter turn and the door mechanism will release.

Rotate the left hand bolt clockwise and the right hand bolt anti-clockwise.

Carefully lower the door open until it reaches the stop.

Remove the ceramic carton and the glass carton from the combustion chamber and put in a safe place whilst the installation continues.

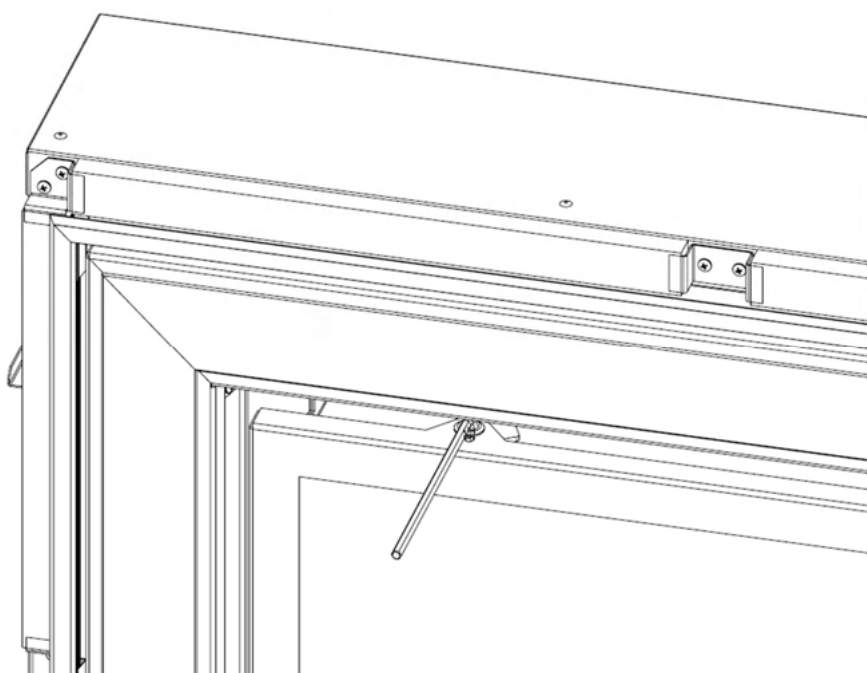

REMOVING THE GLASS DOOR

With the door open and held firmly, slide the glass assembly to the left and it will release from the left hand hinge. Move this corner towards you so it is clear of the hinge.

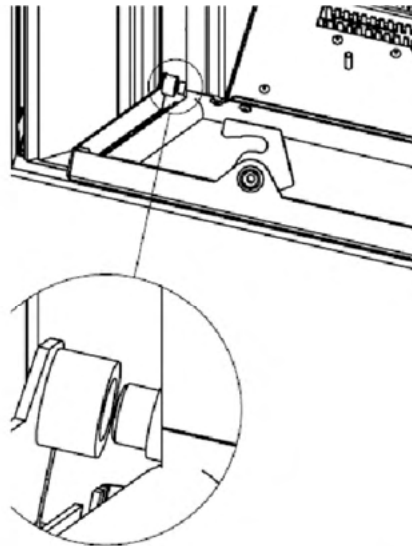
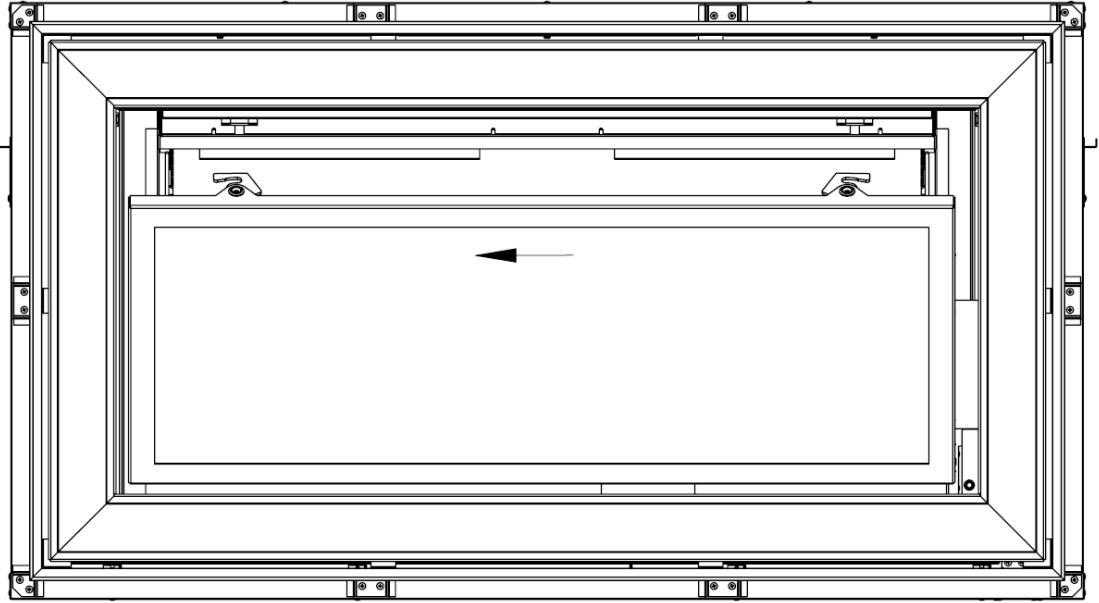

With the door held firmly, slide the glass assembly to the right and it will release from the right hand hinge. Move this corner towards you and the door is now released from the appliance.

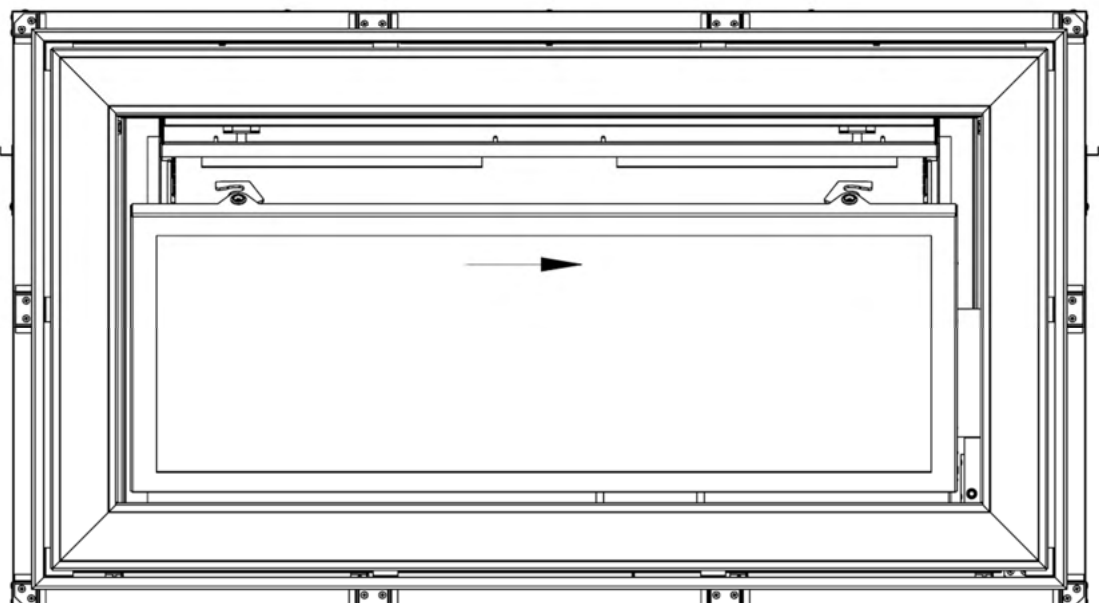

Put the glass door in a safe place until required to avoid causing damage.

REMOVING THE APPLIANCE FROM THE OUTER BOX

The appliance is installed into an outer box. This box provides the housing for the installation. The outer box will be installed into the wall/cavity and provides full mounting features for the appliance and allows easy installation and removal of the gas appliance at a later time should it be necessary.

Using a Philips screwdriver, first remove the 12 screws used to hold the appliance securely during transportation

These screws are used only for transportation purposes. Once removed, they can be discarded.

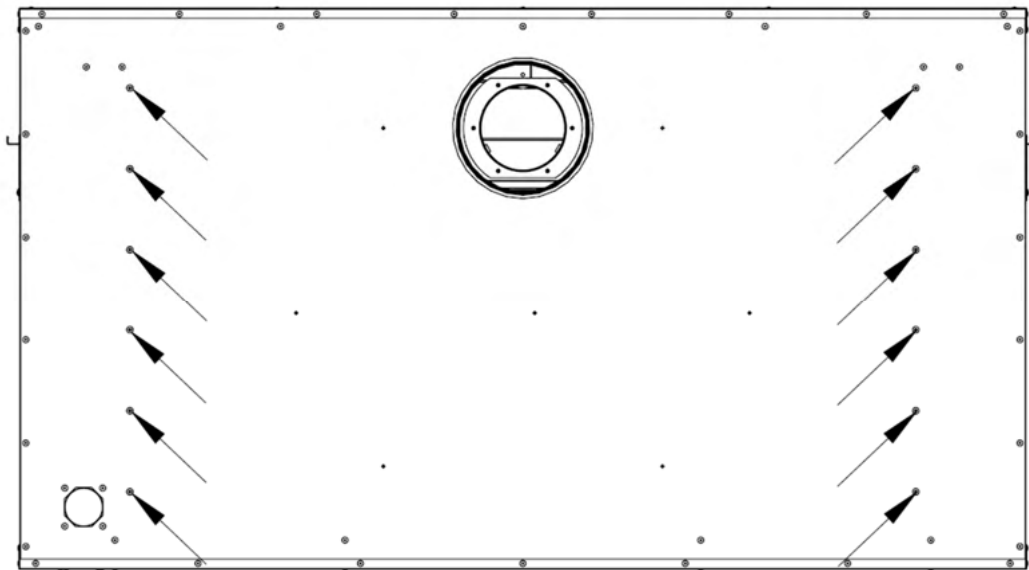

Now remove the **2 screws and two nuts*** which fix the fire into the outer box. These parts will be needed to refit the appliance after the outer box is installed into the wall.

*** These two nuts are not fitted when the appliance is shipped. They can be found in the installation fitting pack.**

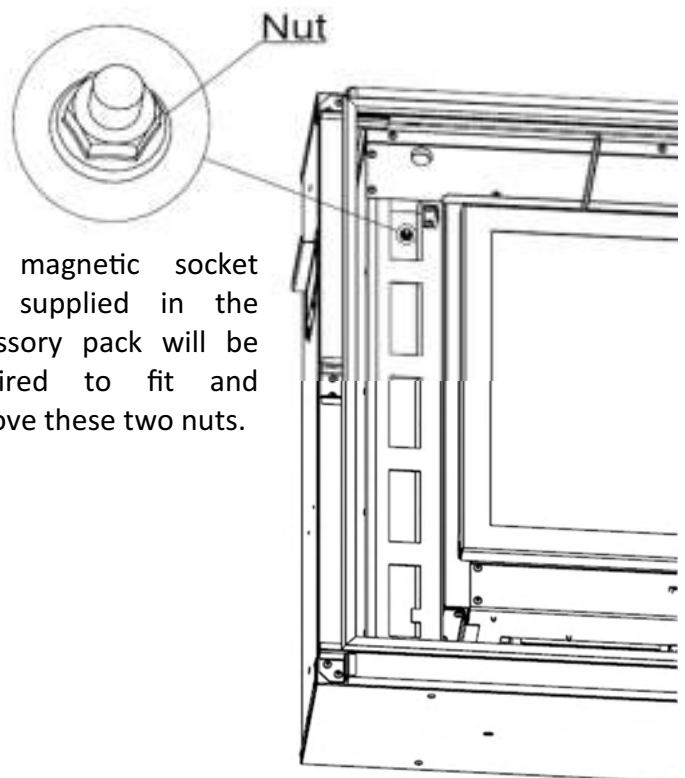
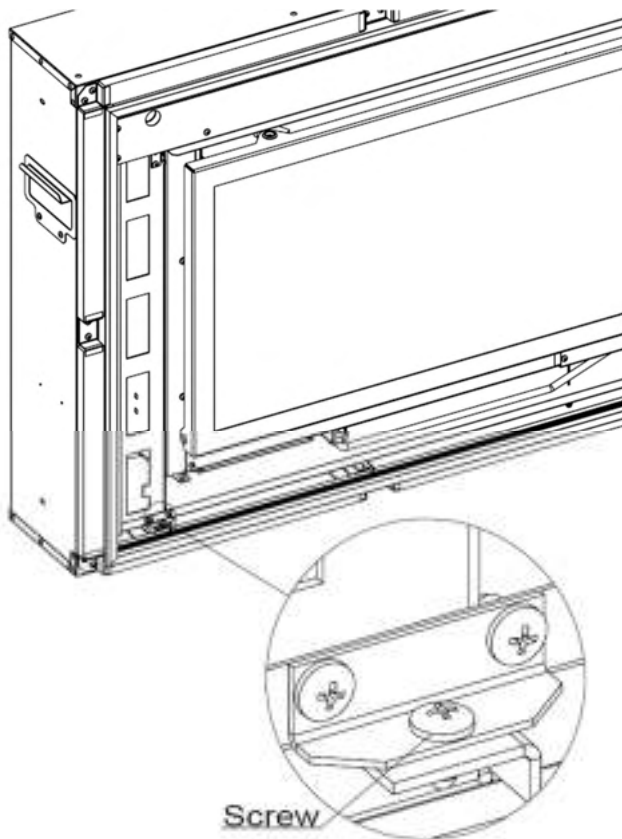

The magnetic socket tool supplied in the accessory pack will be required to fit and remove these two nuts.

The appliance can now be removed from the outer box.

Put the fire aside where it cannot be damaged whilst the outer box is installed into the wall.

PREPARING THE CAVITY WALL

It is necessary to install a lintel above the cavity that will be created to install the appliance. The hole which must be created in the block wall should be 1220mm wide by 690mm high. The outer box requires only 1200mm x 670mm however an extra 10mm should be allowed around the perimeter to line the cavity with non combustible board—this prevents heat from entering the cavity. The lintel required to support the recess in the inner leaf (brickwork) should either be steel or reinforced precast concrete. The lintel should be the depth of the inner brickwork and be at least 1500mm long. Mark the wall at the appropriate place, checking it is horizontal and square. Mark the position for the lintel centrally over this hole position. Remove the plasterboard and blockwork from this area and install the lintel using a suitable mortar. See diagram below.

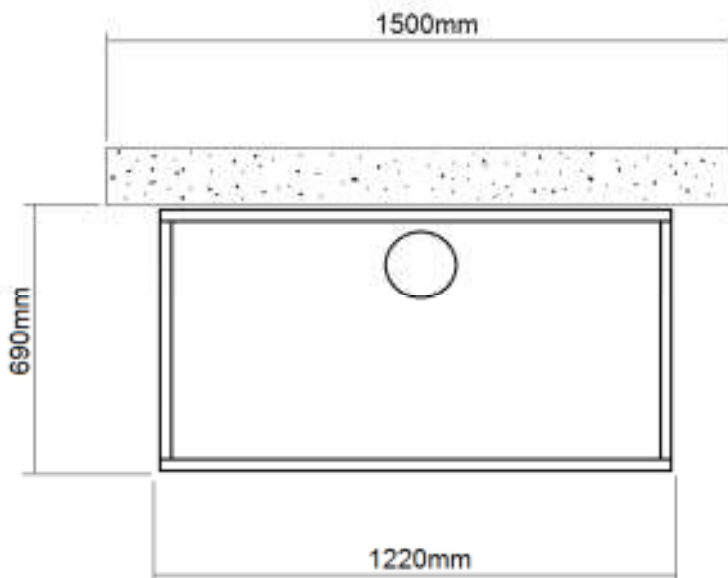

Once the lintel is secure, proceed to remove the plaster, plasterboard and inner block work to the correct dimensions.

The plasterboard should be removed in the area shown in the diagram below

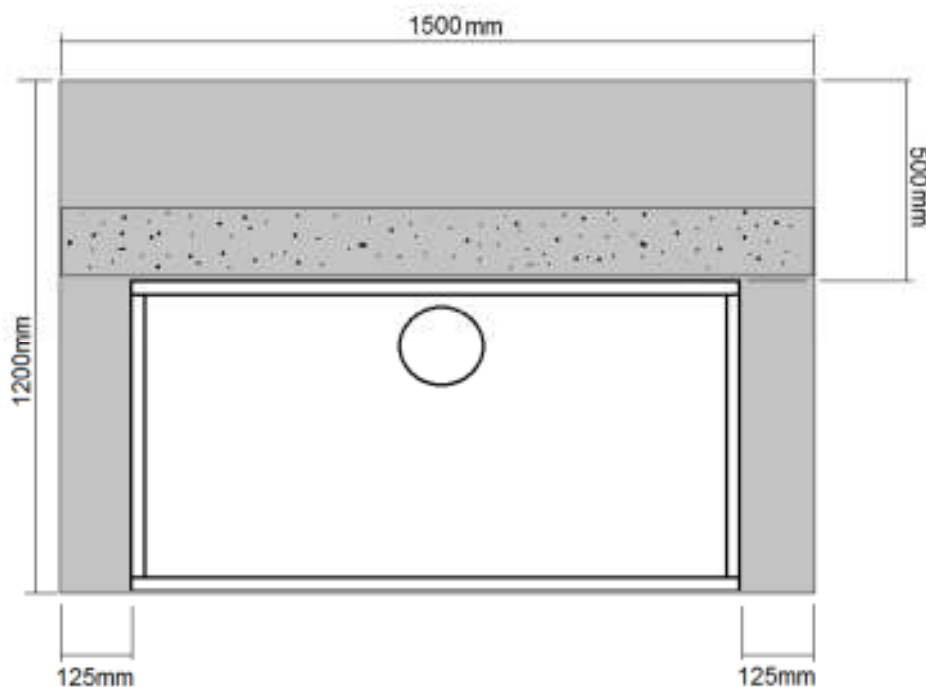

PREPARE THE GAS SUPPLY

The gas supply can be prepared for a concealed fitting from the lower right side or rear of the outer-box. . In all installation conditions the gas connection should be provided using 8mm (O/D) copper tubing. The relevant 'knock-out' entry point should be removed to allow the gas supply to enter the appliance. **No soldered joints** should be used within the cavity or within the outer box of the appliance.

A gas soundness test should be performed prior to any gas work being undertaken to ensure that the existing pipe work in the property is sound.

The gas connection to the appliance is detailed on page 14 and 15. The connection to the appliance will be made using the 8mm restrictor isolation valve supplied with the appliance.

If any part of the gas pipe will be situated in the cavity it **MUST** be sleeved in accordance with BS6891. Flexible sleeving is permitted.

All gas supply pipes should be fully purged prior to the connection to an appliance. Blocked injectors caused by debris shall not be covered under a warranty claim.

The gas pipe should be prepared and installed into the correct position to allow its entry into the outer-box at the desired location. This pipe should be left extended outside the wall in the lower left corner of the outer box by at least 80mm. This can be cut to length once the appliance is ready to be installed.

It is permitted to drill the outside wall and pass the gas pipe through to the appliance. In this installation the rear entry hole should be used.

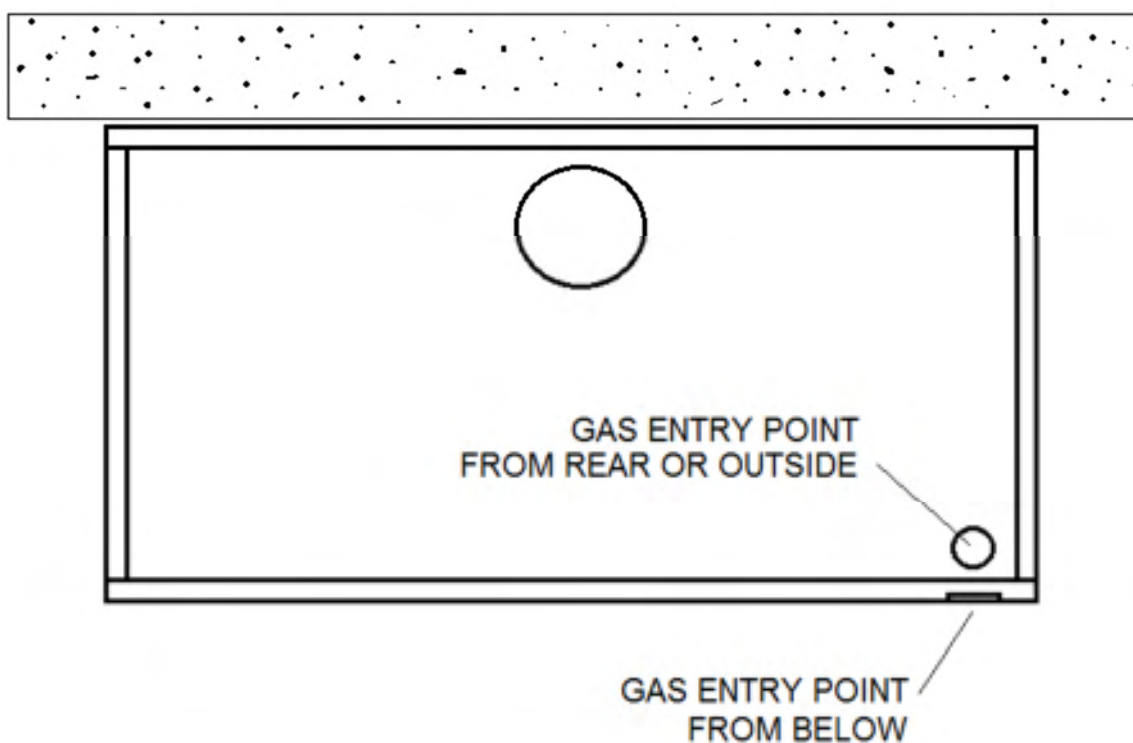

INSTALLING THE OUTER BOX INTO A MASONRY CAVITY WALL

The outer box should be installed temporarily into the new opening to check for fit and alignment. Once this has been established, use the hole at the back of this box to mark the position of the flue. Take care to mark this accurately to ensure optimal performance from the appliance.

The back of the outer box should not touch the outside wall, a clearance of at least 5mm should be allowed between the two, ensuring there are no non-combustible materials in this vicinity.

Align the outer box so that the front protruding lip of the outer box is flush with the existing plastered wall. The non combustible board which will be installed after the box is secured should sit into this reveal.

HIGH TEMPERATURE FIRE SURROUND LINING SYSTEM (i.e. PROMAFOUR OR EQUIVALENT)

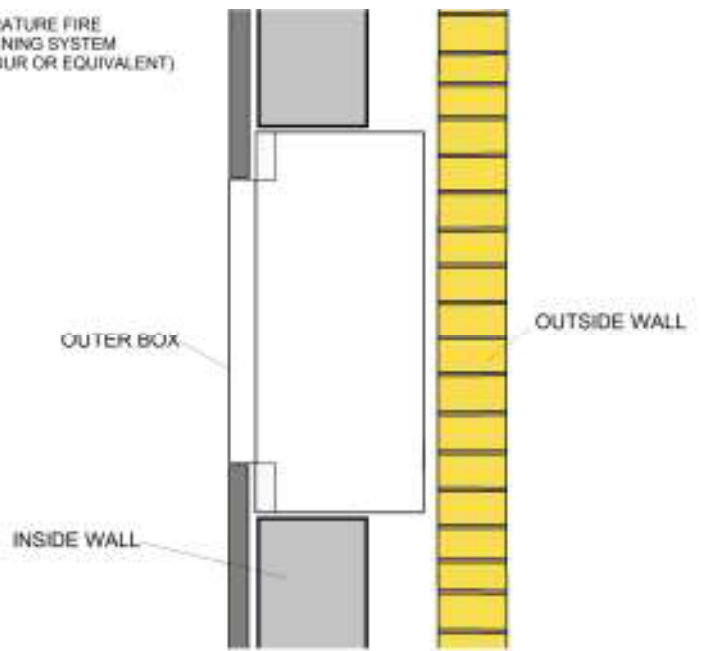

INSTALLING THE OUTER BOX INTO THE CAVITY WALL WITH SLIPS

If the appliance is to be installed with marble or limestone slips around the opening then the ceramic infill sections surrounding the outer-box opening need to be removed. See the diagram opposite showing how to remove these 10 strips.

Remove the 10 ceramic strips from the perimeter of the outerbox

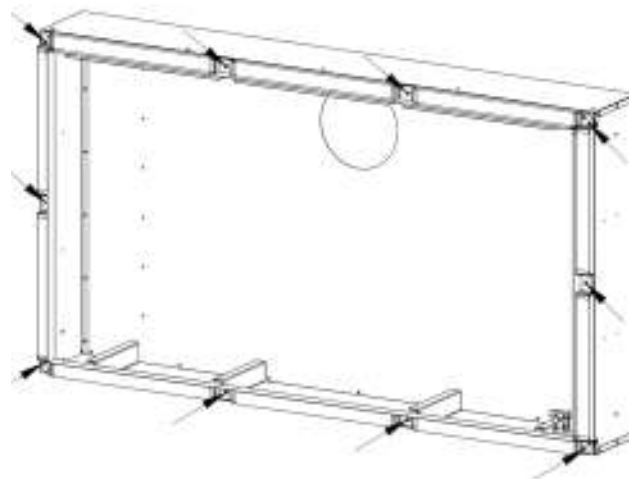

The front lip of the outer-box should then be installed so that it is aligned with the front edge of the limestone slips as shown in this diagram.

High temperature fire surround lining system, (i.e. Promafour or equivalent)

Limestone / Marble Slips

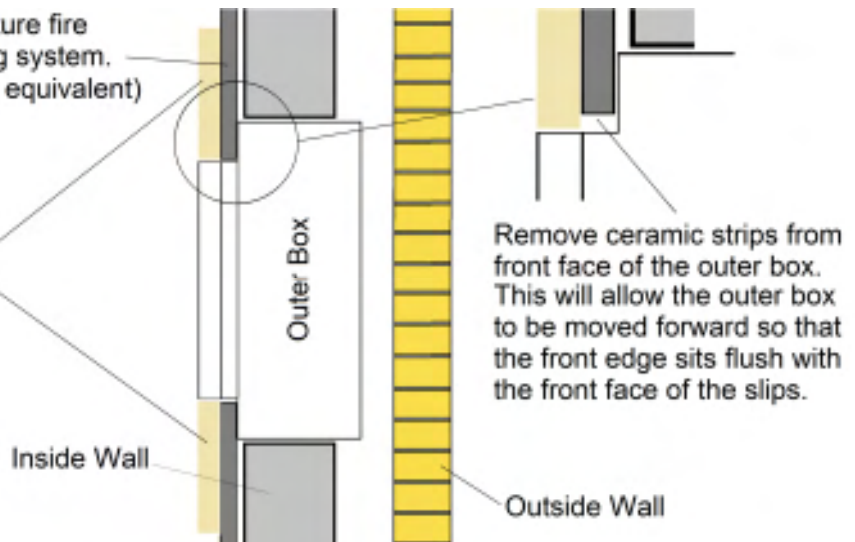

Remove the outer box and drill the hole for the flue (6" diameter) and drill the securing holes with an appropriate masonry drill.

When drilling the hole it is advisable that a pilot hole is drilled first. The 6" Ø hole should be drilled to approximately half the brick depth then complete the hole by drilling from the outside of the building, this will ensure that the entry and exit of the hole are clean.

Mark the fixing positions of the outer box, as shown in this diagram. Two holes in the base and one hole each side near the top of the box. Take care in marking these positions to ensure the appliance is sitting plumb and parallel to the wall.

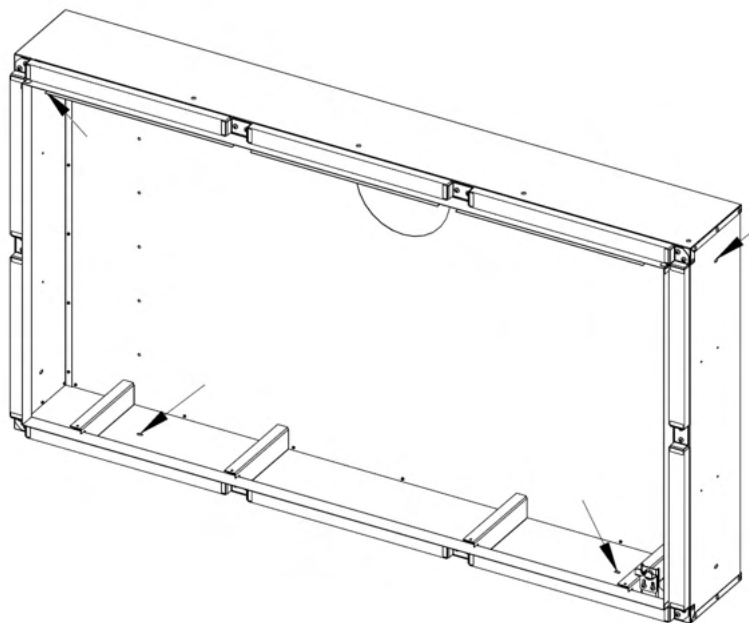

Ensure that all dust and rubble is removed from the area. If any wall cladding exists ensure that it is removed and then pack the cavity surrounding the opening with at least 5" (125mm) of Rockwool above and at each side. All four sides of the cavity should now be lined with non combustible board to ensure that heat cannot enter the cavity.

Make good the wall around the high temperature board.

To ensure that no cracking occurs between the existing plastered wall and the new high temperature board, fix the two materials securely to the wall and to each other around the joint line. Then, using a suitable filler material, blend the two surfaces in preparation for decorating to take place.

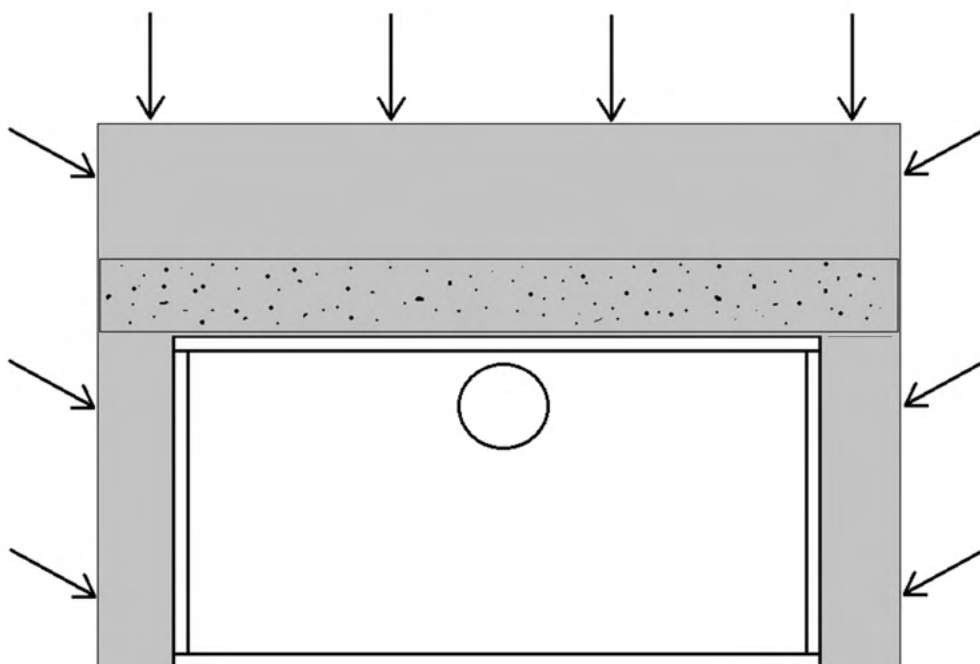

INSTALLATION INTO STUDWORK

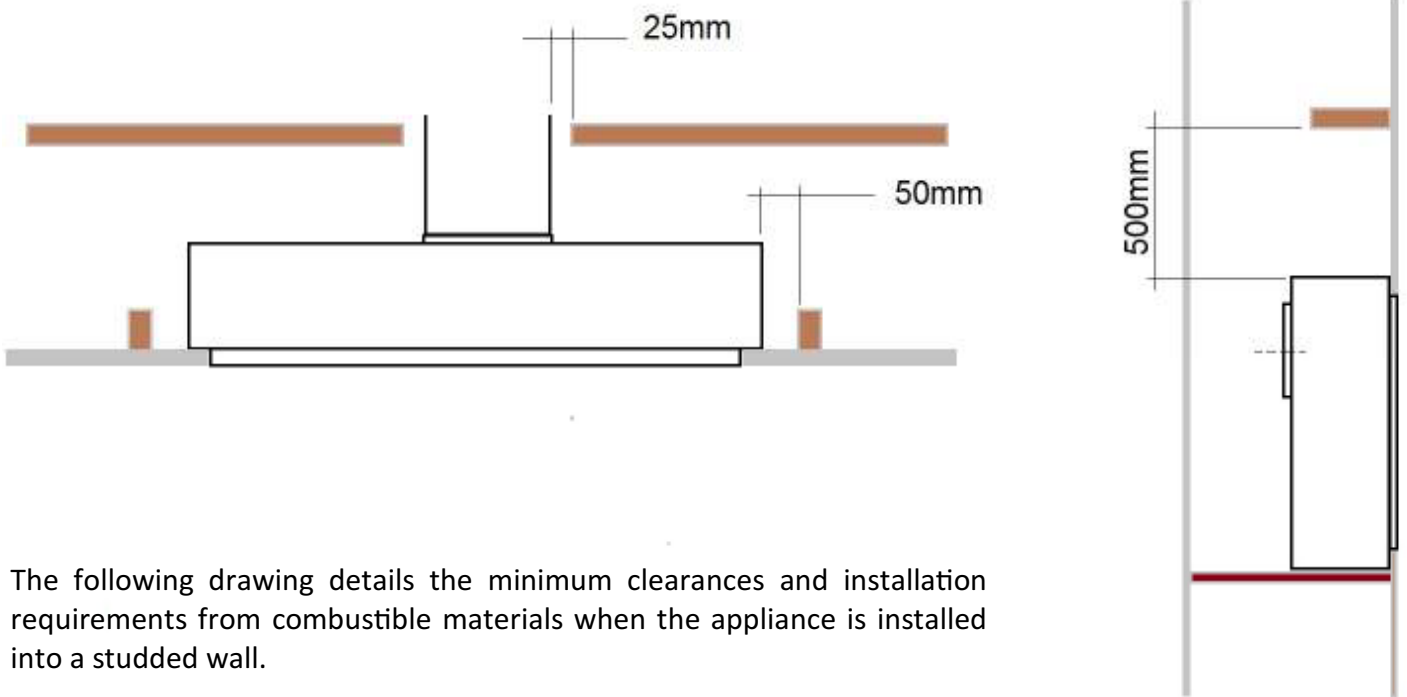

The following drawing details the minimum clearances and installation requirements from combustible materials when the appliance is installed into a studded wall.

A chamber should be created for the appliance outer box installation. The chamber should be manufactured using non combustible fire-board of a minimum thickness of 9mm and the clearances from combustibles (above) should be adhered to. Ensure that the chamber is ventilated at the base to allow cool air to enter and ventilated at the top of the chamber to allow warm air to be exhausted into the room. This inlet/outlet vent should have a minimum open area of 100cm².

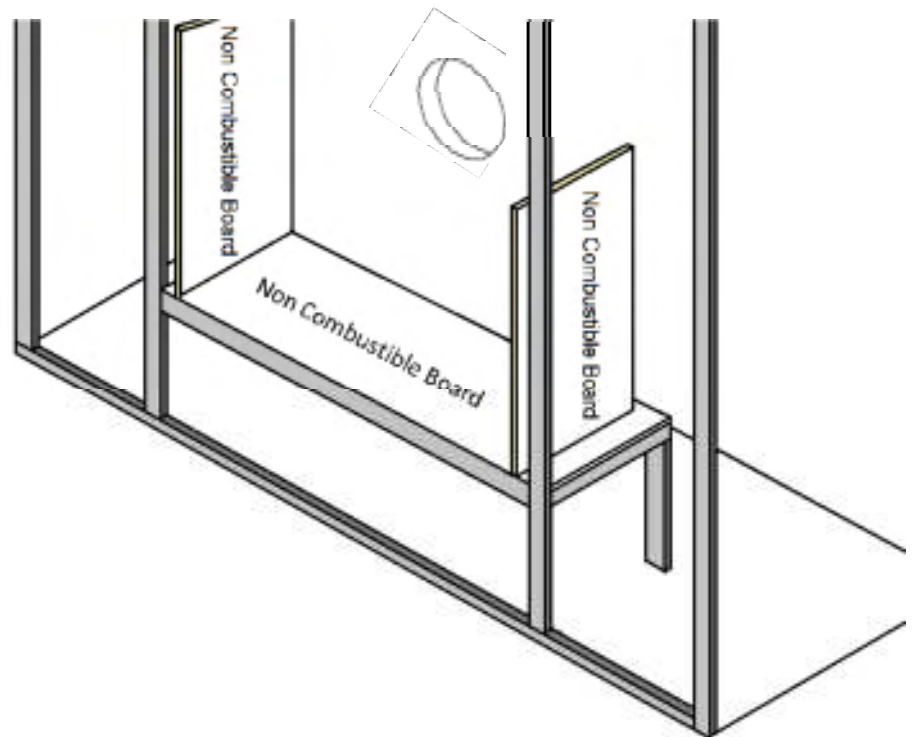

Continue with the installation whilst referring to the cavity wall installation in the previous pages. Again, care should be taken to use a suitable non-combustible board, i.e. Promafour or similar, with no joints around the 'hot area'. This is 500mm above the appliance and 150mm to each side. Fit plasterboard to the front and sides of the chimney breast chamber—ensure an access area is provided for access after installation on one side of this chamber.

Timber Frame Buildings

If the appliance is being installed into a timber framed building the hole through which the flue will pass must have a steel sleeve positioned such that a minimum 25mm air gap exists between the outside diameter of the flue pipe and the metal sleeve – in addition, contact your local building and planning authority (see safety notes on page 3).

FIT THE HORIZONTAL FLUE SECTION TO THE APPLIANCE

DO NOT CUT THE HORIZONTAL FLUE UNTIL THESE NOTES ABOVE HAVE BEEN READ AND FOLLOWED.

The horizontal flue section must be securely fitted to the appliance BEFORE it is fixed into the outer box.

Using the information below calculate the cut length of this portion of the flue. It is recommended that the outer flue is marked at the correct position and then fixed to the appliance (BEFORE CUTTING). The appliance should be **temporarily installed** into the outer box to confirm this length—**test with the terminal cover on the outside wall** to check the flue length required so that it can be fitted to this cover plate on final installation.

Use this temporary installation to also confirm the gas pipe cut length—SEE NEXT PAGE

Once the flue length cut position has been confirmed the appliance can be removed and the horizontal flue length cut and fitted to the rear of the appliance.

It is important to note that flues cut in error will cannot be used for the installation and a new flue will be chargeable. Mark the flue using the calculation and temporarily fit the assembly first to confirm!

The horizontal flue length should be calculated using the following formula.

Amount of flue to remove = 725mm—Dimension A

Dimension 'A' is the distance from the front face of the inside wall to the outside face of the outside brickwork.

IMPORTANT NOTE: IF THE APPLIANCE IS BEING MOUNTED WITH A SET OF SLIPS (SEE PAGE 11) THEN DIMENSION 'A' NEEDS TO BE INCREASED BY THE THICKNESS OF THE SLIPS—THUS REDUCING THE AMOUNT OF FLUE TO BE REMOVED.

When cutting the horizontal flue section, the outer section can be cut from either side, however whichever side is reduced, the 3 securing holes should be re-drilled, using the off cut section as a guide.

The inner flue **MUST** be reduced in length from the side which is installed into the appliance, this is the end **WITHOUT** the locating guides.

Once the **horizontal** flue components have been cut to the correct length connect the inner flue to the appliance by pushing it firmly into the rear spigot. Then fit the outer flue pipe and fix with the 3 screws supplied—into the outer spigot. The inner and outer flue will locate with its pre-installed guides to align the two flues correctly.

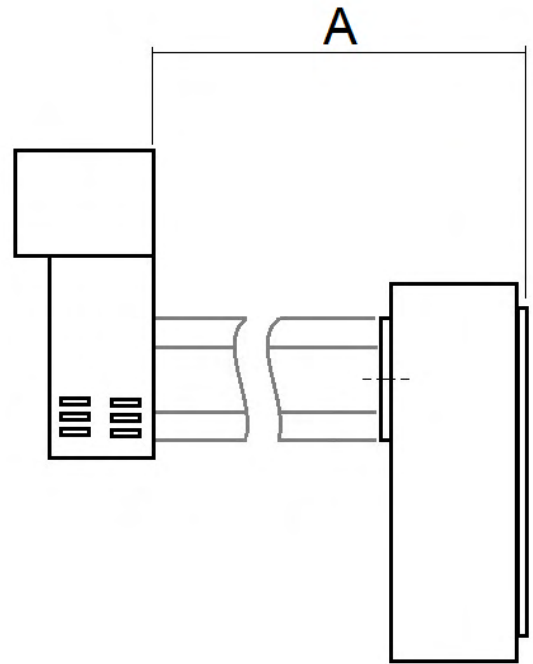

RECORD DATA PLATE INFORMATION HERE

The next page will detail the installation of the appliance into the outer box. Prior to this installation it is recommended that the information on the data plate is recorded for warranty purposes. The data plate can be found on a metal plate at the base of the appliance. Use this area to make a record of this information.

Model No.	F-111XX2
Serial No.	G_____
Installation Date	DAY / MONTH / YEAR

INSTALLING THE APPLIANCE INTO THE OUTER BOX

Once the outer box is installed securely in place and the wall has been made good, final preparations to fit the appliance can now be made.

A dummy run (see previous page) should be carried out so that the gas supply pipe can be cut to the correct length.

With the appliance temporarily in position mark the gas supply length for cutting. Remove the appliance and fit the 8mm restrictor/isolation valve (supplied in the fitting pack) to the gas supply pipe.

Install the isolator before INSTALLING THE APPLIANCE INTO THE OUTER BOX, or the tube nut indicated by the red arrow cannot be reached!

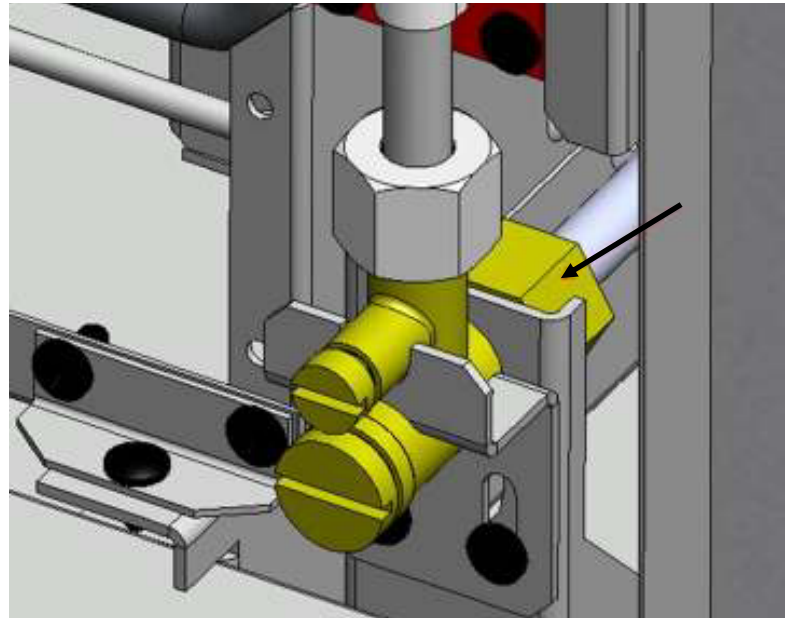

Now carefully lift the appliance into the outer box and guide the horizontal flue section through the outer wall, ensuring the gas supply is sitting in the correct position. The appliance should locate on the two threaded studs at the top left and right of the outer box. Take care that the appliance is fully rearward and these two studs can be seen protruding through their mounting holes.

Finally, install the appliance into the outer box and secure it into position with the two nuts at the top and two screws at the front on the base panel. Use the special magnetic nut tool (with hex head drive) to secure the two nuts (supplied in the installation fitting pack). The magnet will hold the nut securely whilst the drive is aligned with the stud. A torch may be needed to guide the nut to the correct position.

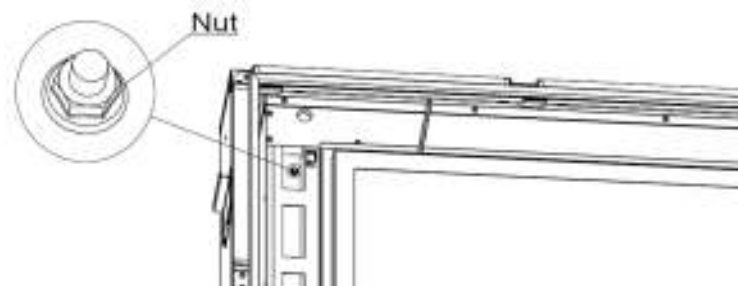
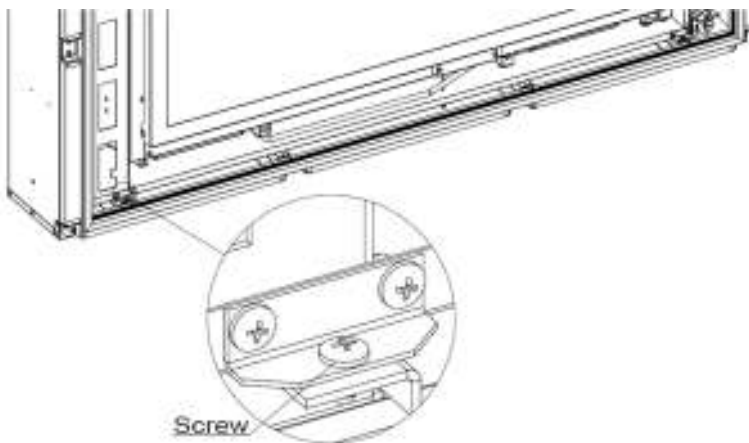

CONNECTING THE GAS SUPPLY

In all installation conditions the gas connection should be provided using 8mm (O/D) copper tubing. The relevant 'knock-out' entry point should be removed to allow the gas supply to enter the appliance. **No soldered joints** should be used with the firebox of the appliance.

Ensure a gas soundness test has been performed to ensure that the existing pipe work in the property is sound.

The connection to the appliance will be made by connecting the appliance inlet pipe to the previously installed 8mm restrictor isolation valve.

FITTING THE TERMINAL

The flue terminal cover plate can now be fitted to the outside wall. Slide the mounting plate over the outer flue, checking the 3 holes line up with the flue, then mark the 4 positions to fix the mounting plate to the wall. Drill the appropriate holes in the outside wall. Using a suitable waterproof sealant (silicone) on the rear face, fix it to the wall using the 4 screws and plugs provided. Now fit the 3 screws to secure the outer horizontal flue to the cover plate. See adjacent diagram.

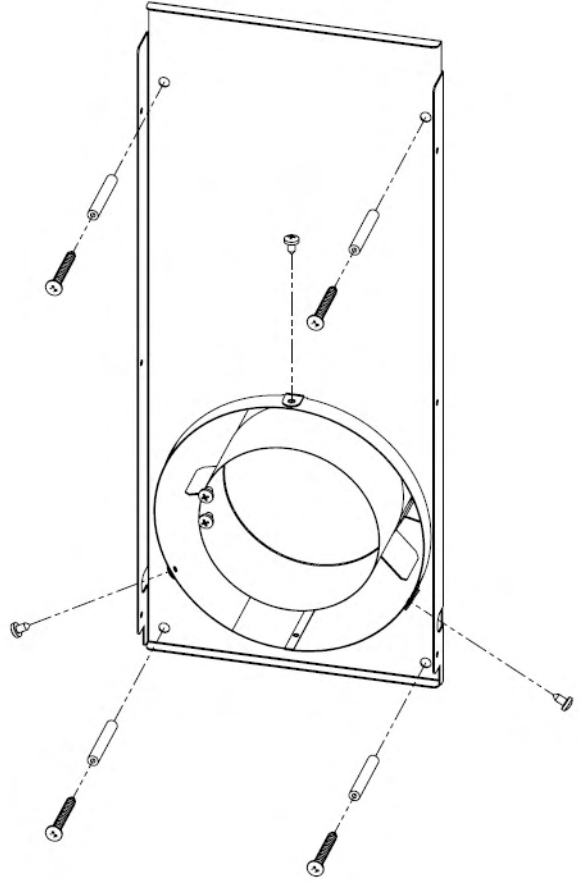

The flue terminal can now be fitted to the outside wall. Ensuring the inner corrugated flue inside the terminal is inserted into the inner horizontal flue, carefully present the flue terminal to the cover plate. Fix the flue terminal to the cover plate using the 6 screws provided—see diagrams below.

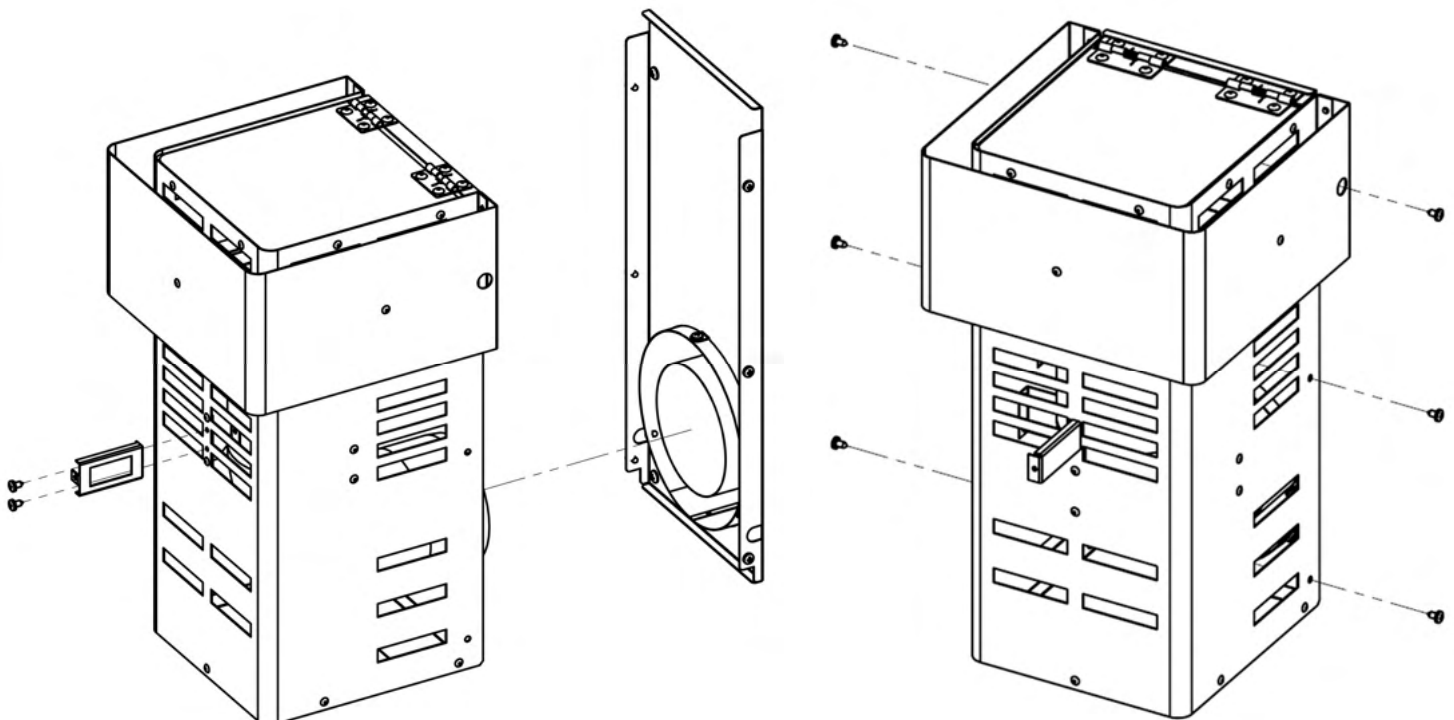

FITTING THE TERMINAL GUARD

The terminal guard can now be assembled and fitted to the outside wall.

In England and Wales the terminal guard supplied with this appliance must be installed if the terminal could come into contact with people moving around the building or if the terminal could become damaged.

If being installed into the republic of Ireland, refer to the current edition of IS813 'Domestic Gas Installations'

If in doubt it is recommended that the terminal guard is always fitted.

Refer to page 4 where the diagram shows where a guard should be fitted and allowable distances from the terminal.

This diagram shows the method of assembly of the terminal guard. The guard should be secured to the wall using the screws and rawl plugs provided.

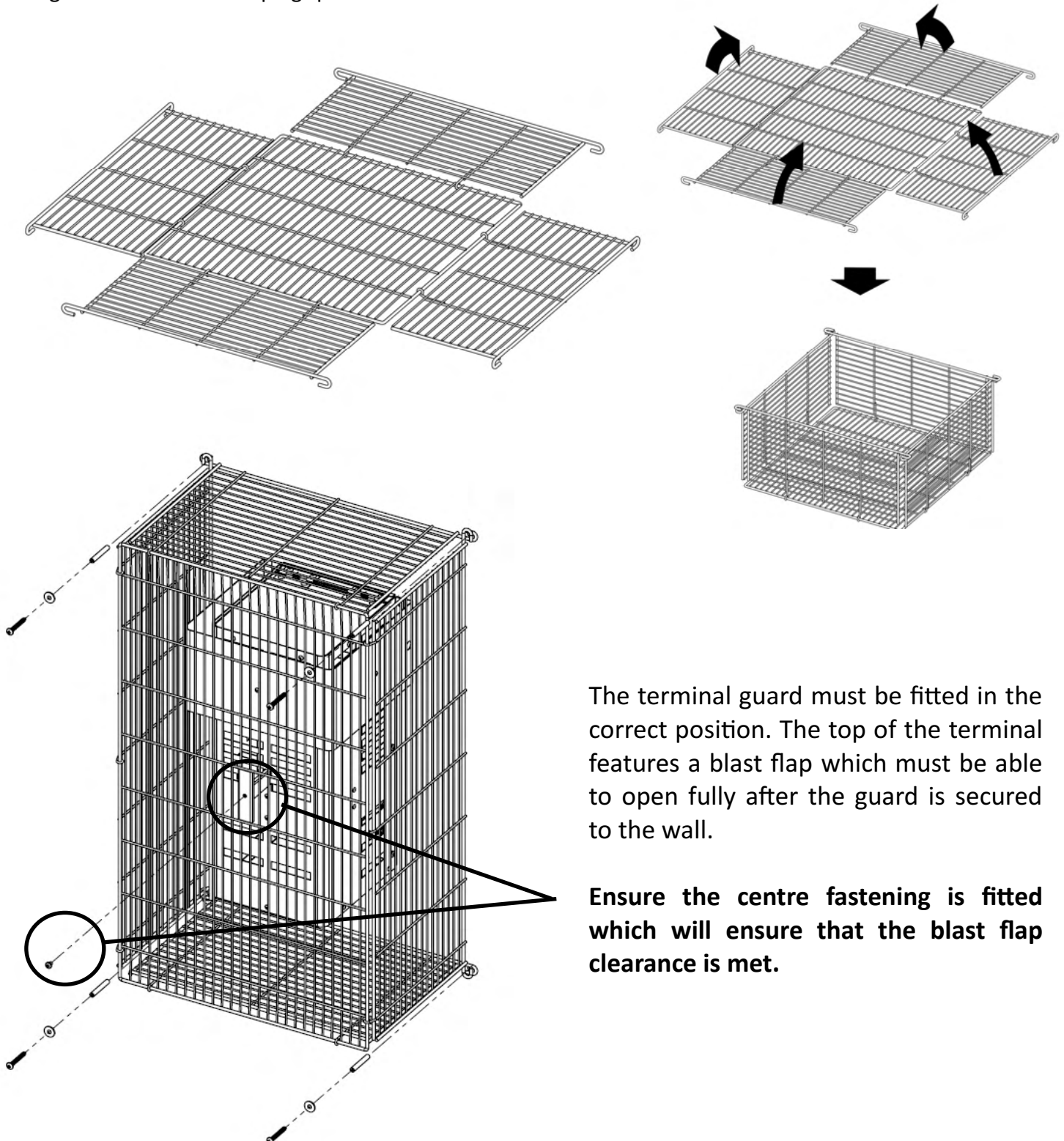

The terminal guard must be fitted in the correct position. The top of the terminal features a blast flap which must be able to open fully after the guard is secured to the wall.

Ensure the centre fastening is fitted which will ensure that the blast flap clearance is met.

Appliance Data

Gas Type	Natural Gas	Battery Type (Electronic Igniter)	AA
Inlet Pressure	20mbar \pm 1mbar	Wall Depth (Min)*	270 mm
Gas Connection	8mm pipe	Wall Depth (Max)*	725 mm
Injector (2 off)	\varnothing 1.37	Fire Depth	186mm
Pilot	P-XX1317	NOx Class	Class 5
Input High Rate (Gross)	6.0kW (0.57m ³ /hr)	Efficiency Class	Class 1
Input Low Rate (Gross)	2.9kW (0.27m ³ /hr)		

* The wall depth is calculated as the distance from the front face of the inside wall (or from front face of slips if fitted) to the outside face of the exterior wall.

FIT THE REAR/SIDE GLASS FITTING

1. The rear and side black glass panels are supplied in a cardboard pack. Carefully unpack the glass panels and install as shown in the 3 diagrams. Ensure the smooth face of the glass pane is facing outwards when fitting them into the appliance.

Fit the 3 rear panels first by pushing the upper edge into the rear upper slot and lifting until it will rotate inwards and sit down on its lower edge.

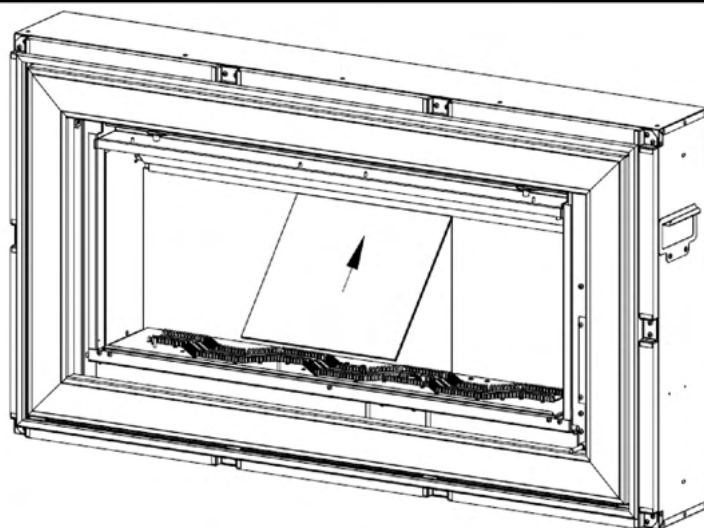
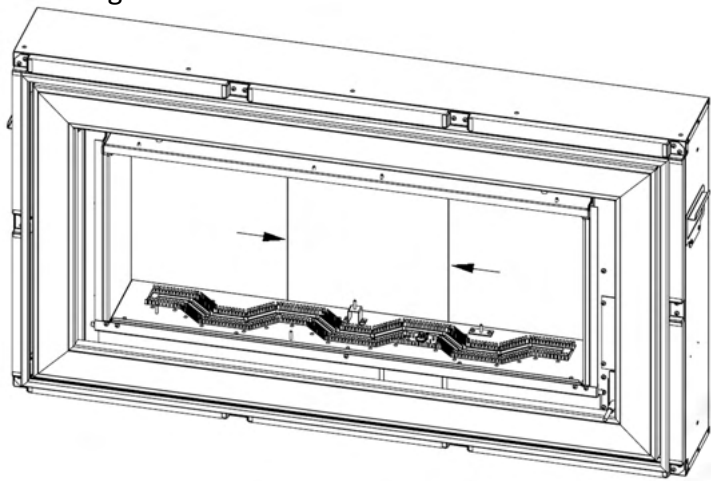

2. Ensure the three panels are pushed together so there is no gap between the panels. Gaps between the panels are not covered under warranty so ensure that these are fitted correctly before proceeding.

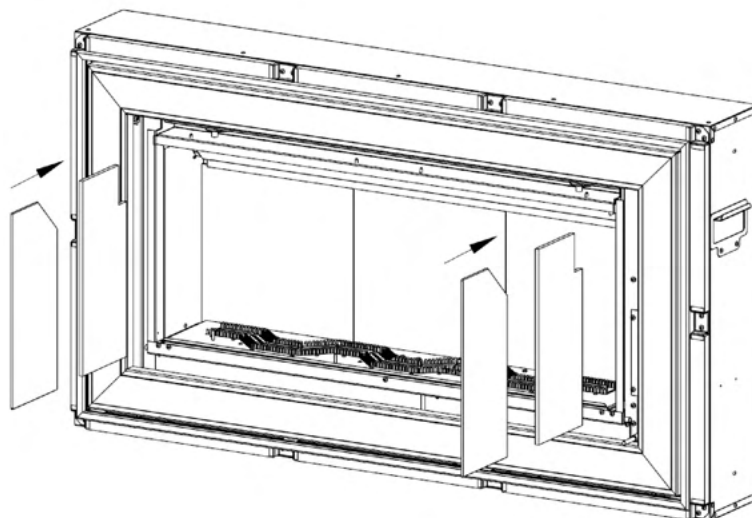

3. Finally, fit the side glass panels and side liners as shown here. Slide the liner in first and then slide the glass side panel in until it touches the rear glass panels.

INSTALL THE CERAMICS AND REFIT THE GLASS DOOR ASSEMBLY

HEALTH AND SAFETY NOTICE

This appliance uses fuel effect pieces manufactured from Refractory Ceramic Fibres (RCF). Care must be taken to avoid excessive exposure to these materials as they may cause irritation to the eyes, skin, nose and throat. When Handling avoid inhaling and contact with skin and eyes. It is recommended that disposable gloves are worn in addition to a facemask and eye protection. After handling wash hands thoroughly and any other exposed parts which may have come in to contact with the material.

If a vacuum cleaner is used to clean the fuel bed or areas around the appliance there fragments of the material may have fallen it is recommended that it be of the type fitted with a HEPA filter.

Care should be taken when disposing of RCF materials. It is important to keep any dust to a minimum so it is recommended that the fuel effect components are placed into a heavy duty plastic bag. The bag should be clearly labelled **RCF WASTE**. These materials are not classified as hazardous waste and should be disposed of at a site approved for the disposal of industrial waste.

Refer to page 31 for full instructions on the arrangement of the volcanic rock, ceramic logs and ceramic bark. Great care should be taken with the layout or incorrect flame patterns may result. Incorrect fuel bed layout which results in a warranty call request will not be validated.

Now fit the door using the reverse procedure employed for its removal. Simply slide the right hand side of the door assembly onto the right hinge, then lift the left hinge into position and slide the assembly to the right.

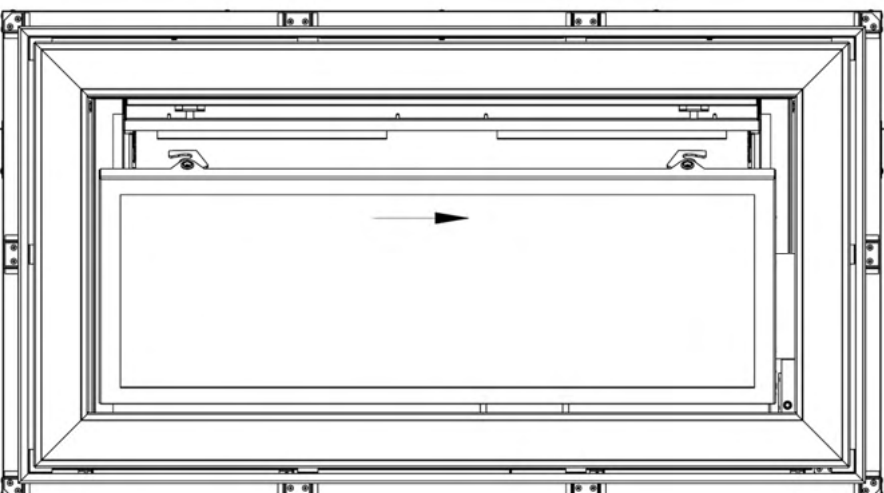
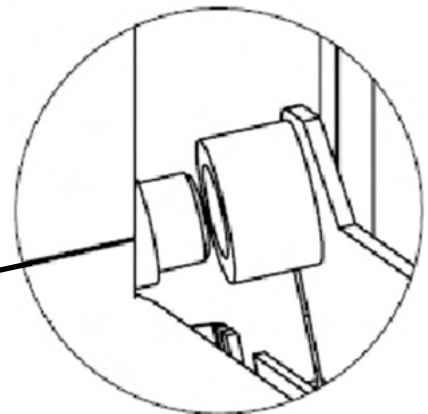
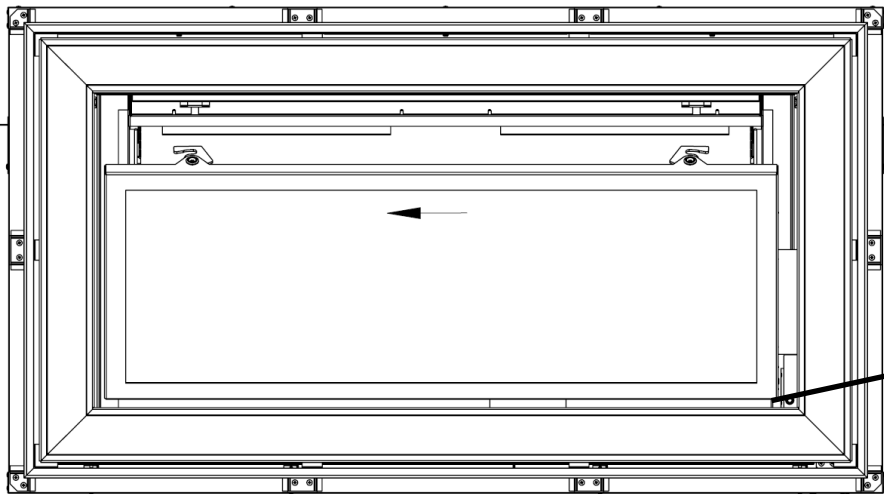

CHECK APPLIANCE OPERATION

Ensure that gas is turned on at the gas meter and purge the air from the gas line. Test the operating pressure of the appliance by attaching a pressure gauge to the test point of the appliance. This connection should take place when the appliance is OFF. Follow the instructions below to light the appliance.

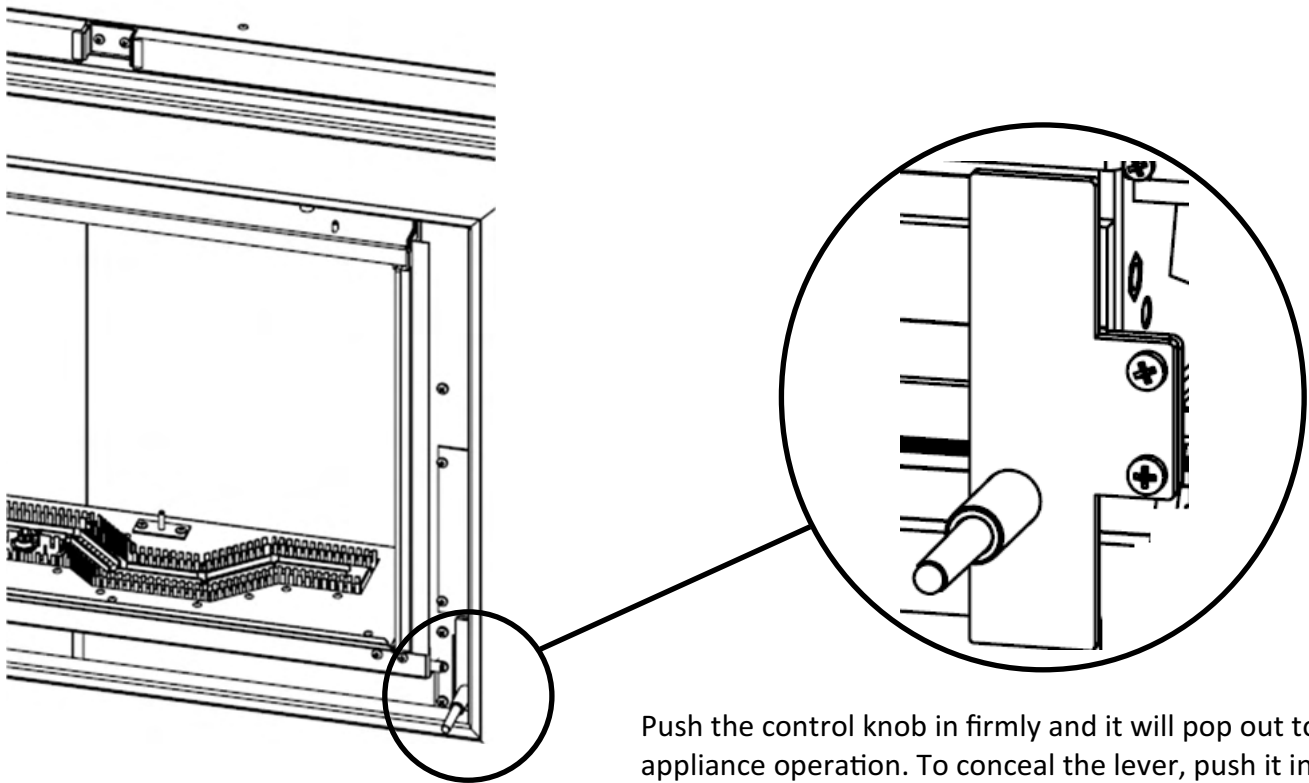

Push the control knob in firmly and it will pop out to allow appliance operation. To conceal the lever, push it in again firmly and the lever will return to its concealed state.

Push down the control lever fully to the ★ (IGN) position and hold. The spark generator should spark continuously, ensure the spark is being generated correctly at the pilot assembly. Continue with this procedure until the air is purged from the appliance and the pilot and main burner are lit. Once lit hold the lever pushed down for up to a further 10 seconds. Once the pilot is established and secure allow the lever to rise to the 🔥 (LOW) position then lift the lever to the 🔥 (HIGH) position. Allow the appliance to run for a minimum period of 5 minutes. Next check that the inlet pressure to the appliance is 20 mbar \pm 1 mbar.

To turn off the appliance, lift the slide lever to the ● off position.

If the appliance is extinguished or goes out, wait for 3 minutes before attempting to relight the appliance.

The flames will appear blue until the appliance reaches temperature. This can take between 10 and 20 minutes. The customer should be advised of this fact.

It is advised to use this opportunity to show the customer the position of the electronic igniter.

They should be advised that this part is concealed behind the trim, and replacing the battery will involve the removal of the trim.

Advise that one battery of the AA type is required. The positive (+) terminal should face outwards.

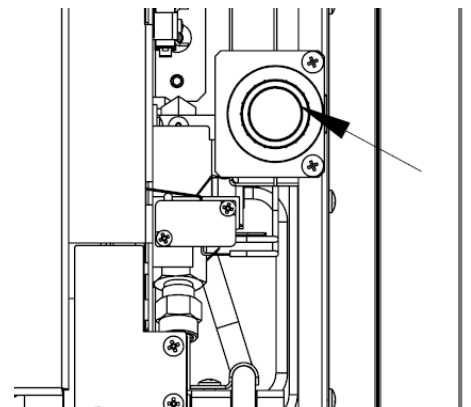

REFIT THE TRIM AND OUTER TRIM

Completing the Installation of the Appliance

Remove the protective covering (if applicable) from the face of the decorative trim. Fit the trim to the appliance very carefully ensuring the outer trim clip assemblies sit correctly within the outer box.

This advice **must** also be passed onto the consumer to ensure that they are aware of trim removal and reinstallation for battery changes—see page 20 for details of electronic igniter location.

Secure the trim by fitting the two screws at the top of the trim as shown in the diagram above.

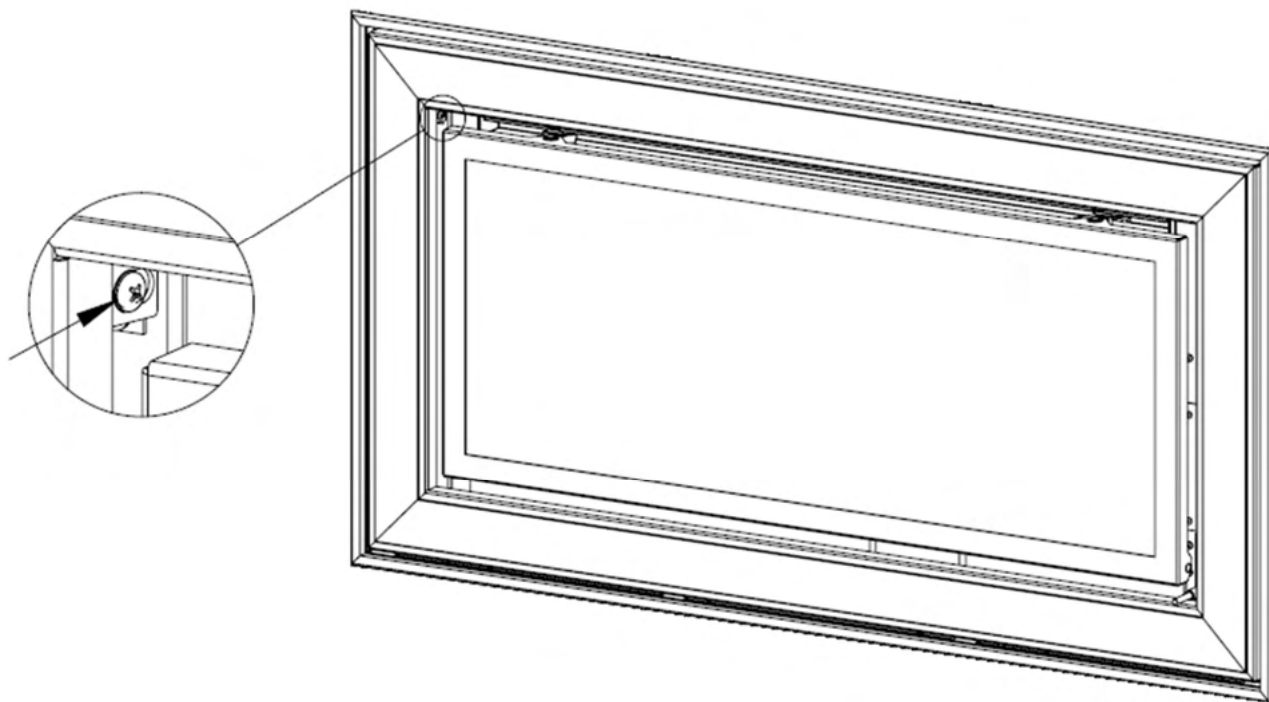

Check that the outer trim assembly is sitting correctly in the slotted brackets located around the entire perimeter of the main trim body.

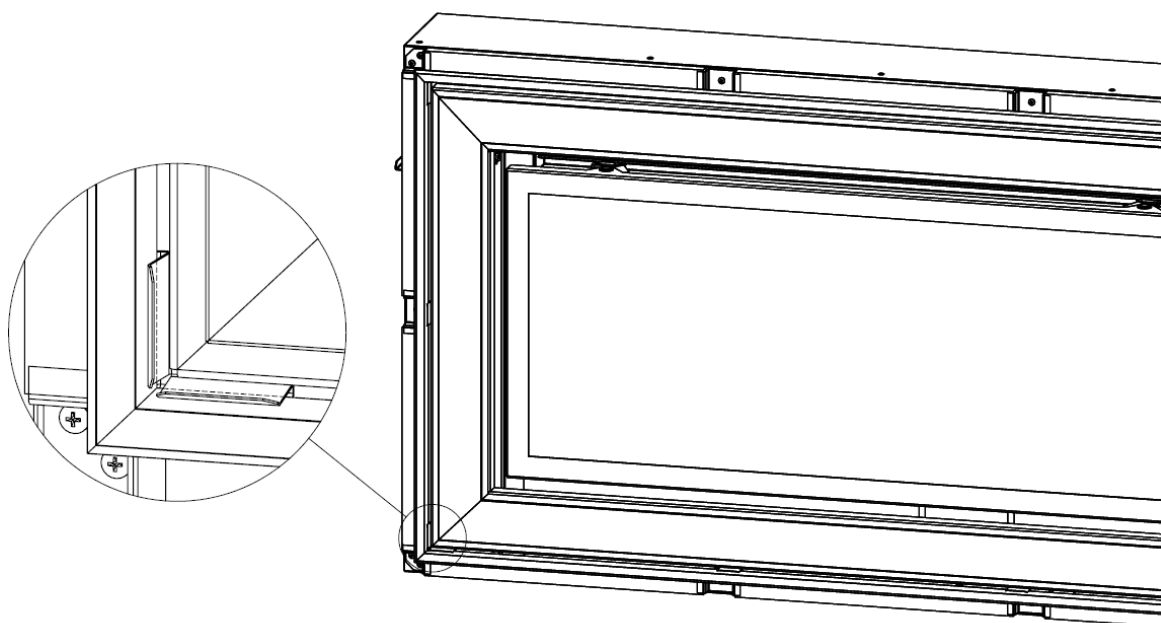

Recheck the appliance operation and complete the appliance Commissioning Checklist on page 38

IMPORTANT CUSTOMER INFORMATION

THE INSTALLER MUST INFORM THE CUSTOMER OF THE FOLLOWING TO COMPLETE THE INSTALLATION

Demonstrate the lighting of the appliance and the controls to control the heat settings. Demonstrate how to extinguish the fire.

Demonstrate the removal of the trim and how to reinstall correctly.

Demonstrate igniter batter replacement procedure.

Discuss the removal and reinstallation of the glass and the ceramics. Explain how they should be cleaned and make the customer aware of the health and safety warning detailed earlier in these instructions.

Explain to the customer that the ceramics are fragile and must be treated with great care, explain that the ceramics are not covered by the warranty because of their fragility. Also explain that small hairline cracks will appear in the surface of the ceramics due to heat expansion and contraction—this is perfectly normal.

During the first several hours of use an odour will be experienced— This odour is non toxic and will eventually disappear with use. It is recommended that the appliance be run for several hours on high setting with a window or other suitable ventilation to allow the odour to disperse.

Advise that no rubbish should be thrown onto the appliance and that the appliance should be cleaned regularly.

A vacuum cleaner can be used but it is important that the appliance is turned off and allowed to cool before undertaking this procedure. See the separate section regarding cleaning the ceramics.

Advise the customer that the appliance should be serviced annually by a gas safe engineer to ensure the safety and integrity of the appliance.

Advise the customer that the appliance has a hot glass surface and should be considered a hazard whilst the appliance is running and up to an hour after extinguishing the appliance. The customer should be informed that a suitable fireguard be used for the protection of the elderly, infirm and young children.

The user must be made aware to keep the area immediately in front and around the appliance should be kept clear of combustibles items.

Advise the customer that, should the appliance fail to light, the igniter battery should be checked (demonstrate the sparking at the pilot so clarify this troubleshooting method. If the appliance still will not light, the retailer/dealer should be contacted directly.

These instructions **must** be handed over to the customer once installation is complete.

Maintenance of the Appliance

The following procedures can and should be performed by the **customer** at regular intervals depending upon use of the appliance.

Cleaning the Appliance

Ensure the fire is turned off and has been allowed to cool for a period of at least one hour.

Metal Parts

Metal parts can be cleaned with a slightly damp cloth, once wiped, any moisture should be removed with a soft clean cloth. Do not use any abrasive cloths or cleaning solutions, these may scratch the surface.

Trim

It is important that no abrasive cleaners or chemical agents are used in the cleaning of these components. It is recommended that all these surfaces are cleaned with a clean damp (not wet) cloth.

Fuel Bed

The fuel effect components supplied with this product are extremely fragile and must be handled with great care. The ceramics in this appliance are not covered by the warranty due to their fragility. This includes the RCF fibre boards in the fire box. These components will break or chip if not handled with the greatest of care. Once this appliance has been commissioned, there is no warranty on ceramic components due to their fragility. Spare parts available by contacting the manufacturer directly—find details at the back of this manual.

Cleaning of these components should only be undertaken once the appliance is switched off and has been allowed to cool for a minimum period of one hour. The glass door can be opened to access the fuel bed area. (See page 6 for full details).

The ceramic components should be lifted carefully piece by piece from the appliance and placed onto a dust sheet or similar. They can be brushed gently with a soft brush to remove any dust or deposits. If you intend to use a vacuum cleaner then this should only be done once the loose deposits of soot etc have been removed. Please refer to the health and safety data on page 19. Ensure that the moulded components are structurally sound and no significant part of the moulding has broken away.

If any component has broken then it should be replaced before using the appliance. Only the correct replacement part as supplied by the manufacturer shall be used in this appliance.

Do not add any additional components to the fuel bed layout.

It is important to note that small hairline cracks will appear in the surface of the ceramics due to heat expansion and contraction—this is perfectly normal.

Ensure that the ceramics, volcanic rock and ceramic bark are replaced correctly, as per the instructions in this manual.

SERVICE INSTRUCTIONS

The following procedures can and should **only** be performed by a **Gas Safe registered installer**.

This appliance should be serviced annually by a Gas Safe registered installer.

Removal / Replacement of Gas Carrying Components.

The removal and replacement of all the gas carrying components will require the removal of the outer trim (see page 6) where access can then be gained to all gas carrying components. The following information details the major control components. Once removed, refer to the relevant section that follows detailing the removal of the specific component(s).

- Turn off the gas supply at the isolation valve on the appliance. Ensure the appliance is cold.
- **Remove the glass door (see earlier in this manual)** and fuel effect components - put in a suitable location where they cannot be damaged.
- Disconnect the gas supply from the restrictor elbow.

The diagram below shows the location/removal of the control lever, the restrictor elbow and the electronic igniter.

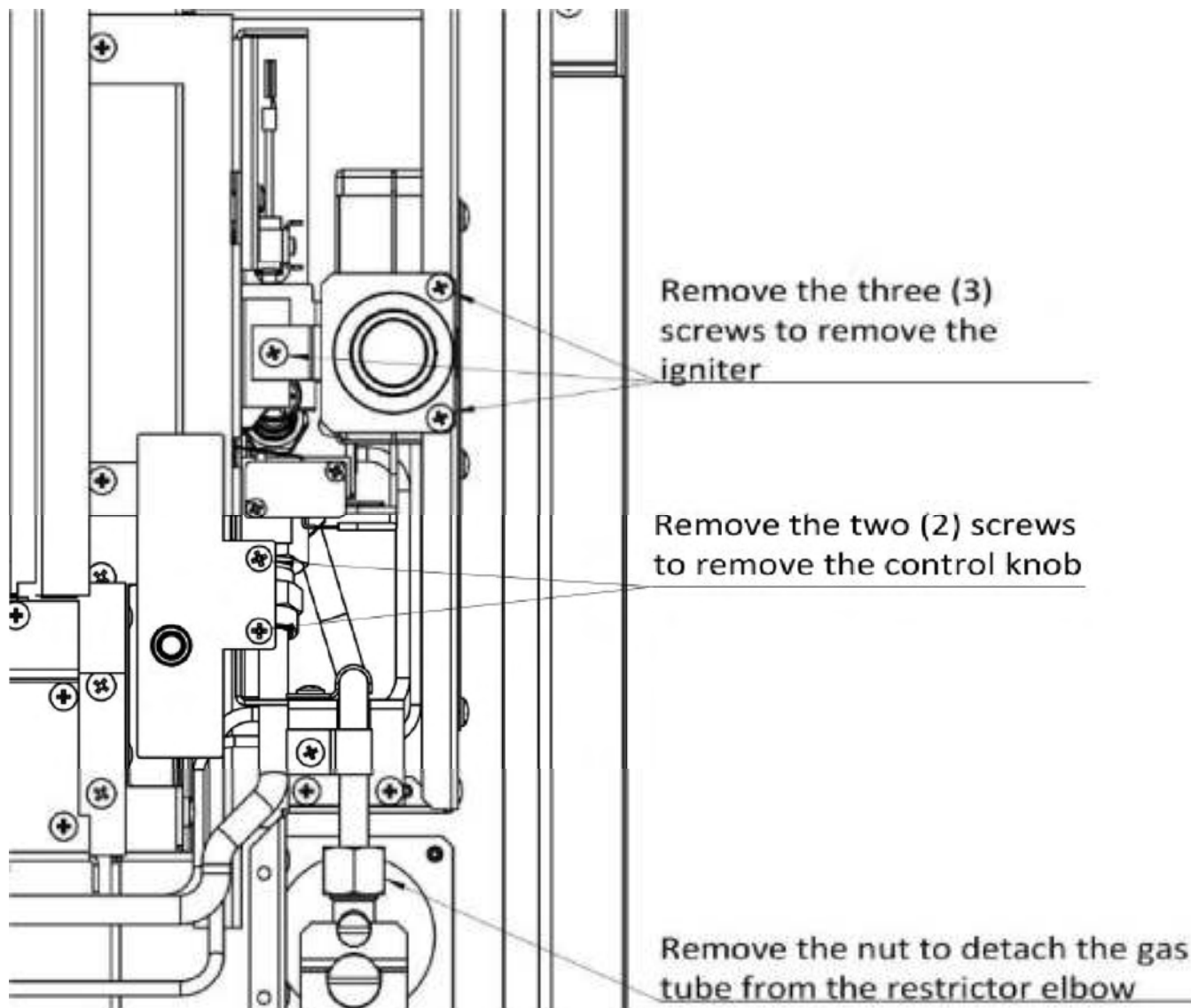

- To access the controls, the side module should be released and swung outwards. After the isolator valve has been restricted, remove the four screws shown in the first diagram.
- Undo the pilot gas supply from the base of the pilot. Refer to steps 1 and 2 on page 27.
- Pull the control module off the locating pin as shown in the second diagram.
- The slide control valve, igniter and both microswitches can now be accessed.

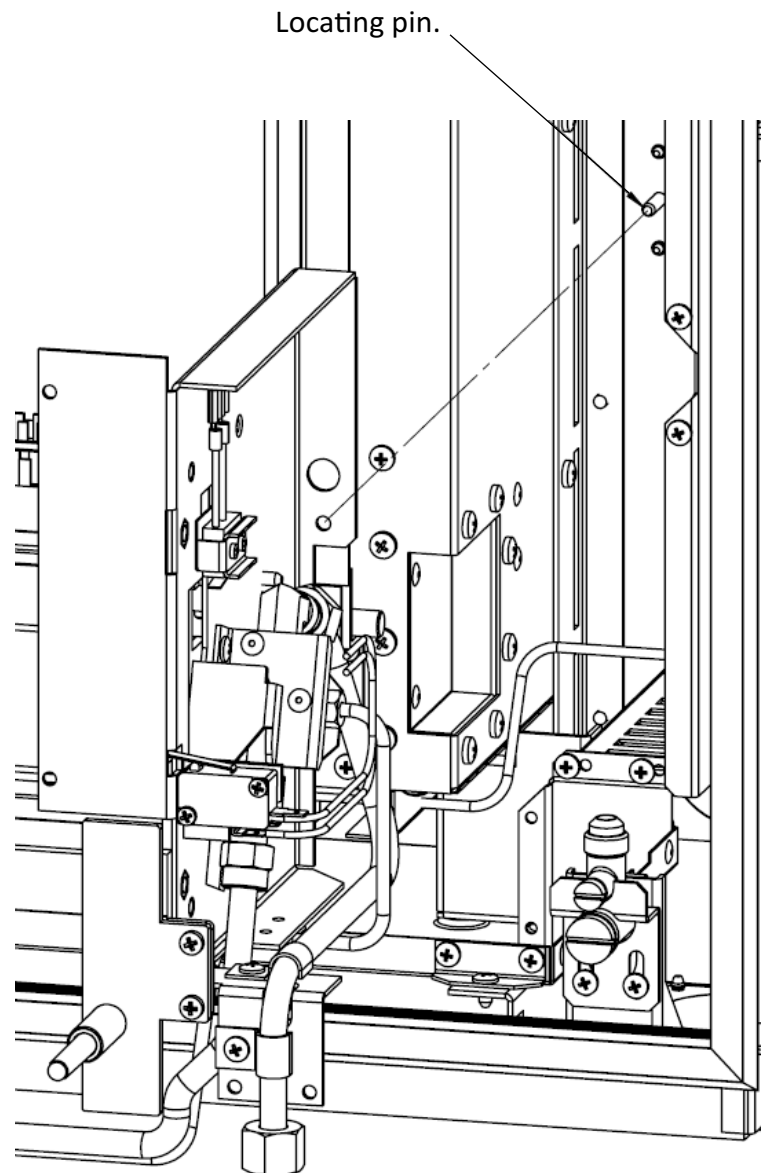
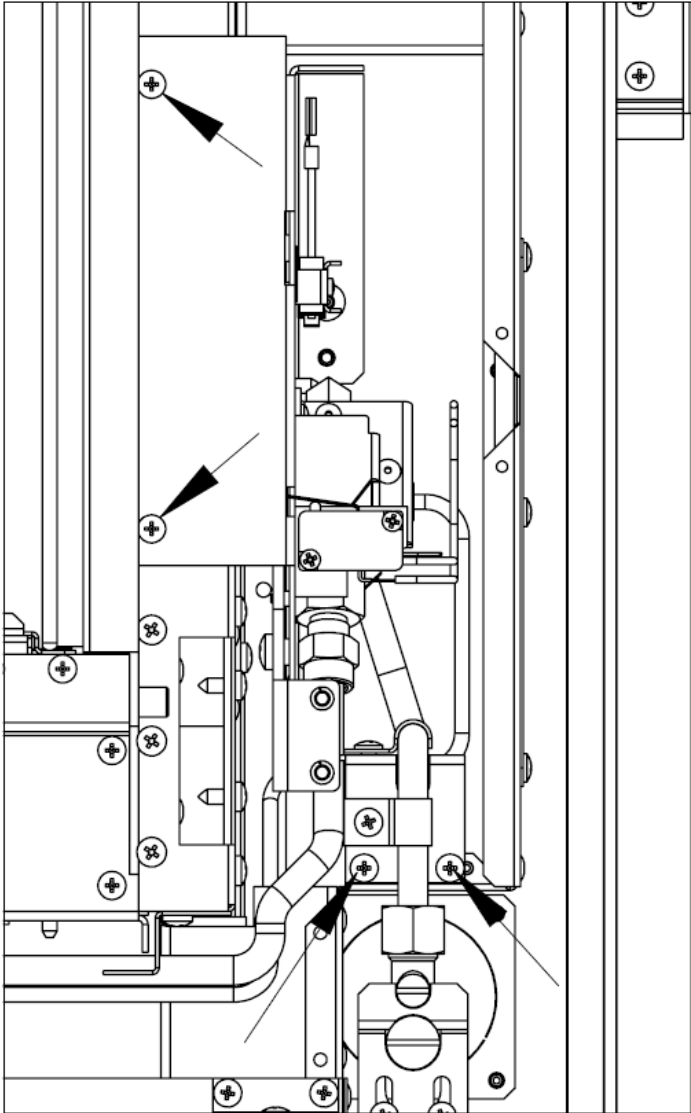

Control Valve Removal/Replacement

1. Remove the two (2) screws and the inlet tube nut. Remove the gas tube.
2. Remove the corrugated tube nut.
3. Remove the pilot tube nut.
4. Remove the valve locking nut and the two (2) screws.
5. Remove the connector from the valve.
6. Re-assemble in reverse order.

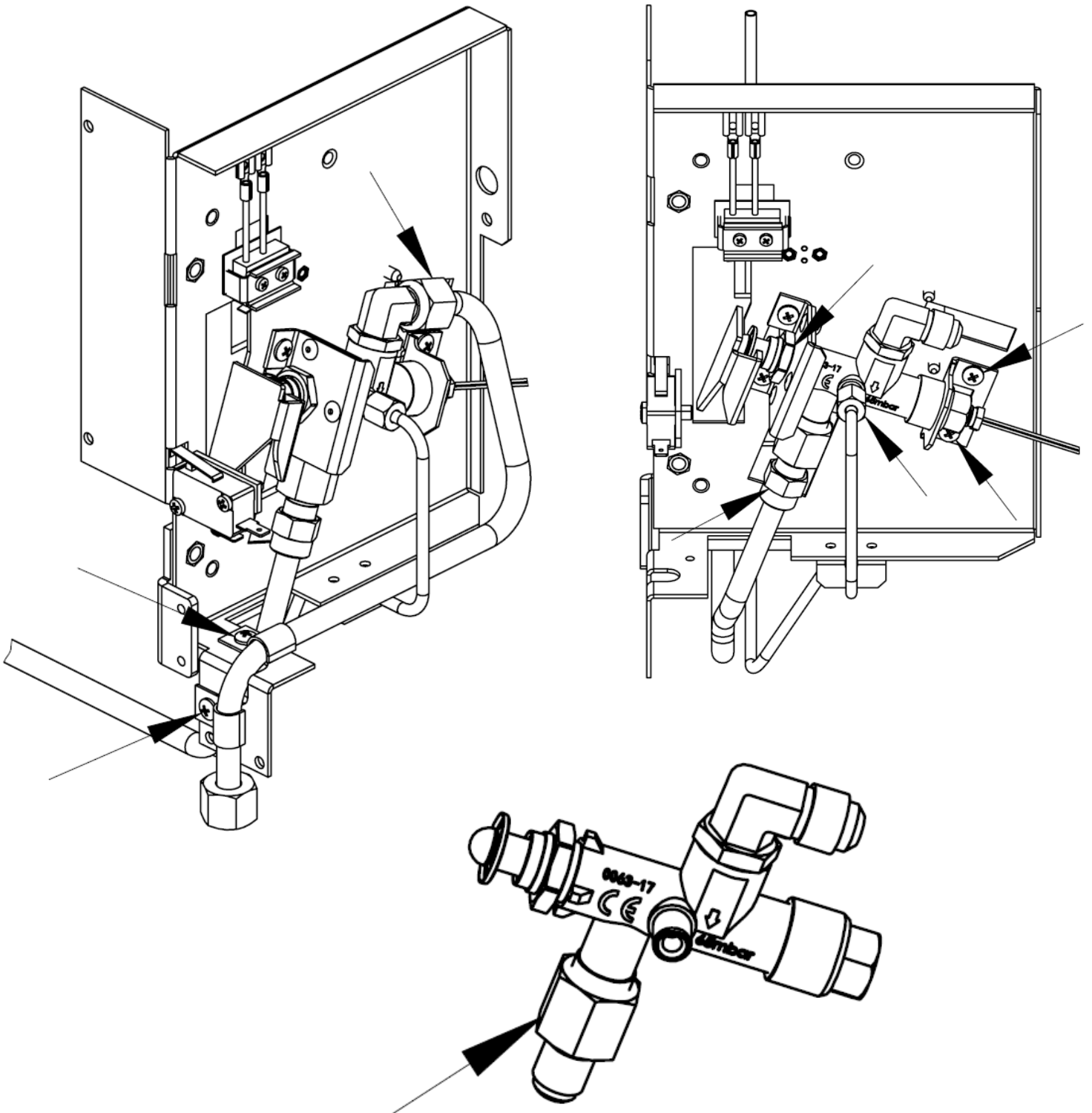

Replacement of the Pilot

1. Remove the two(2) screws to remove the pilot cover.
2. Undo the pilot gas supply from the base of the pilot.
3. Remove the two (2) screws securing the pilot
4. Remove the thermocouple nut from the back of the valve. Remove the two (2) screws securing the micro switch.

Remove the igniter lead from the base of the igniter and the pilot assembly can be removed and replaced.

Re-assemble in reverse order.

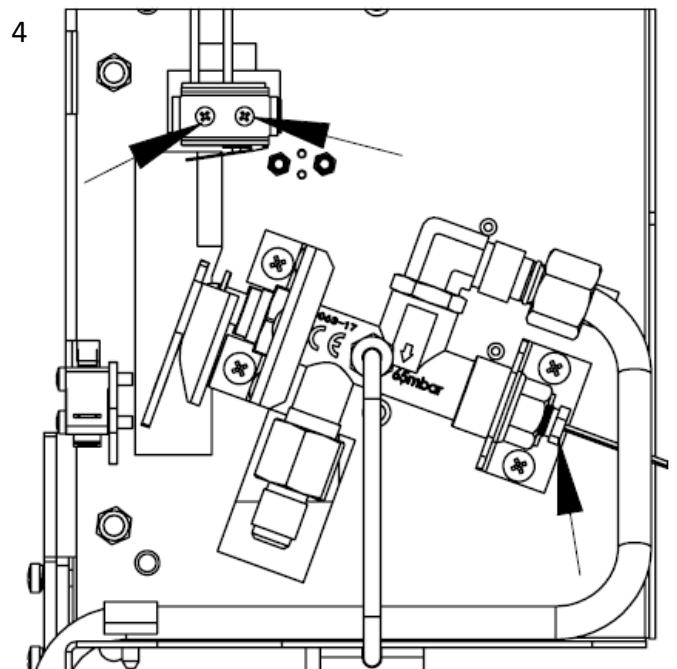
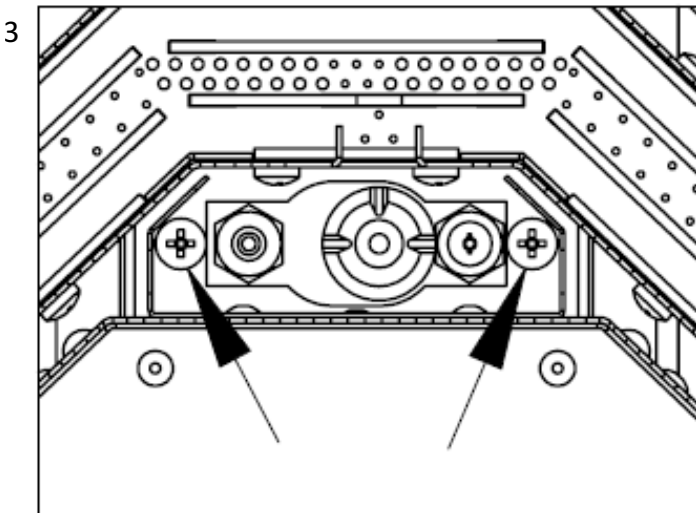
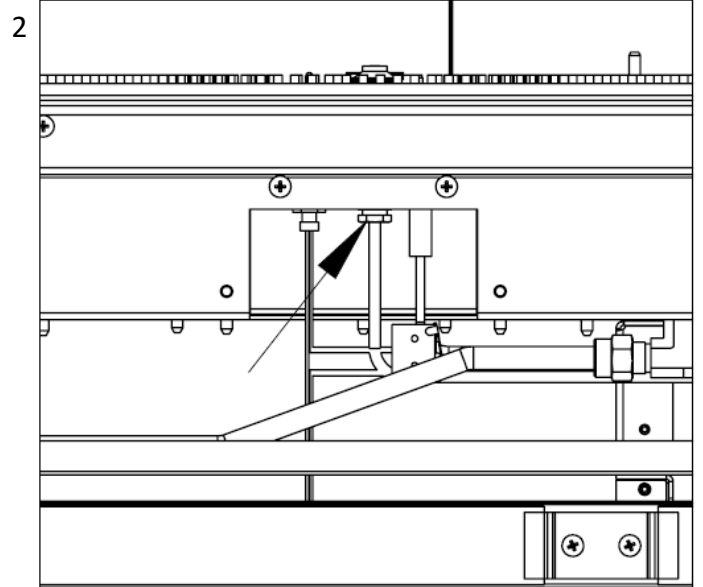
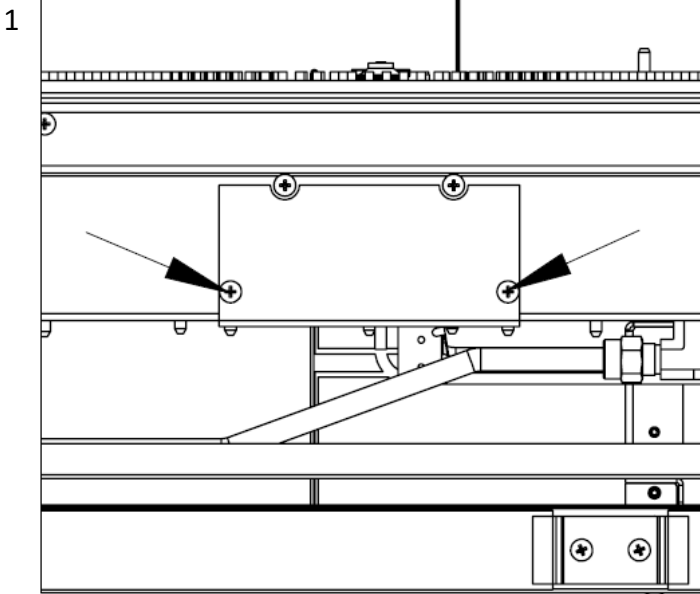

Replacement of the Injector

1. Remove the four (4) screws to remove the log location pins.

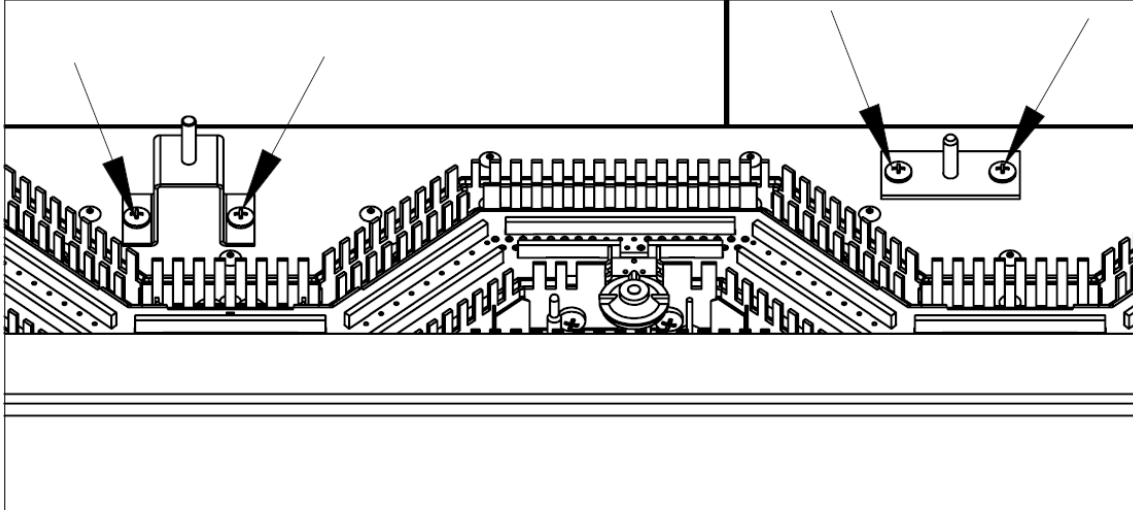

2. Remove the side glass and side liners out as shown below.

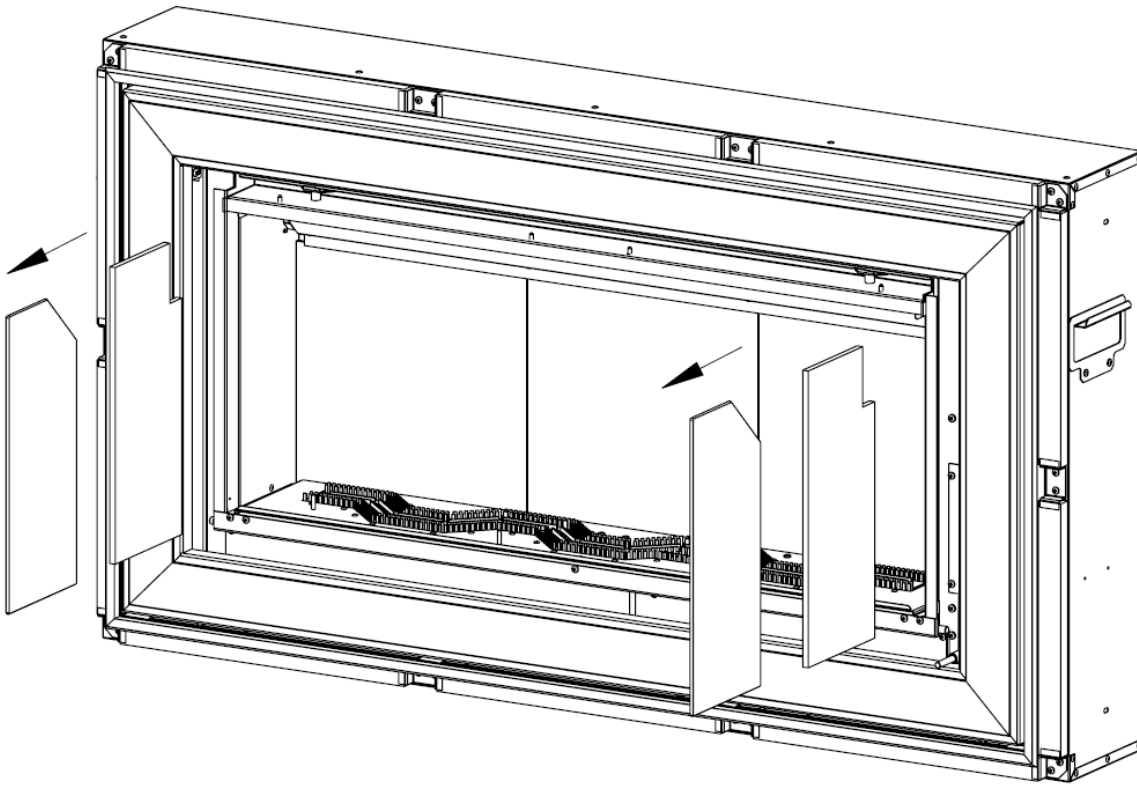

3. Lift the back glass upwards, tilt the lower edge outwards. Remove the back glass panels and the back liners.

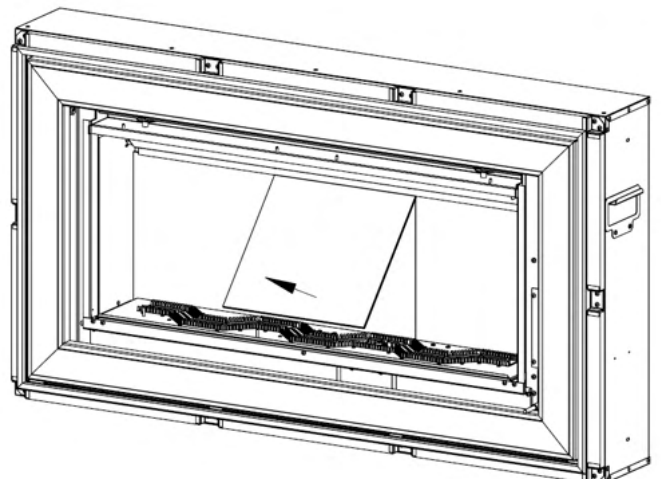
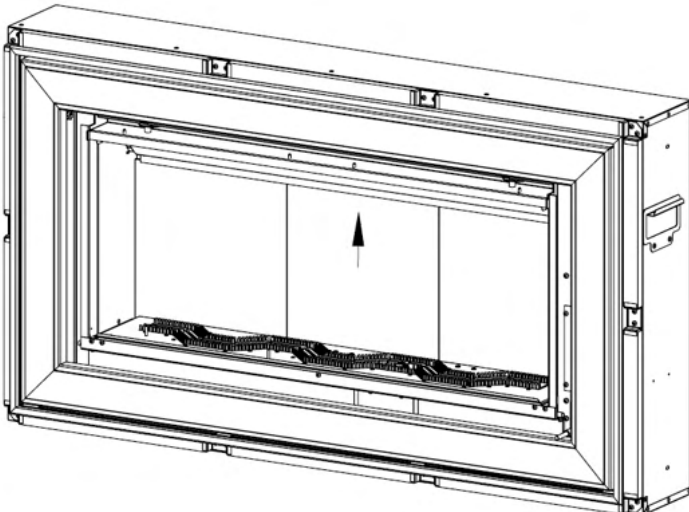

Replacement of the Injector—continued

- 4 Remove six (6) screws to remove ash-pan.

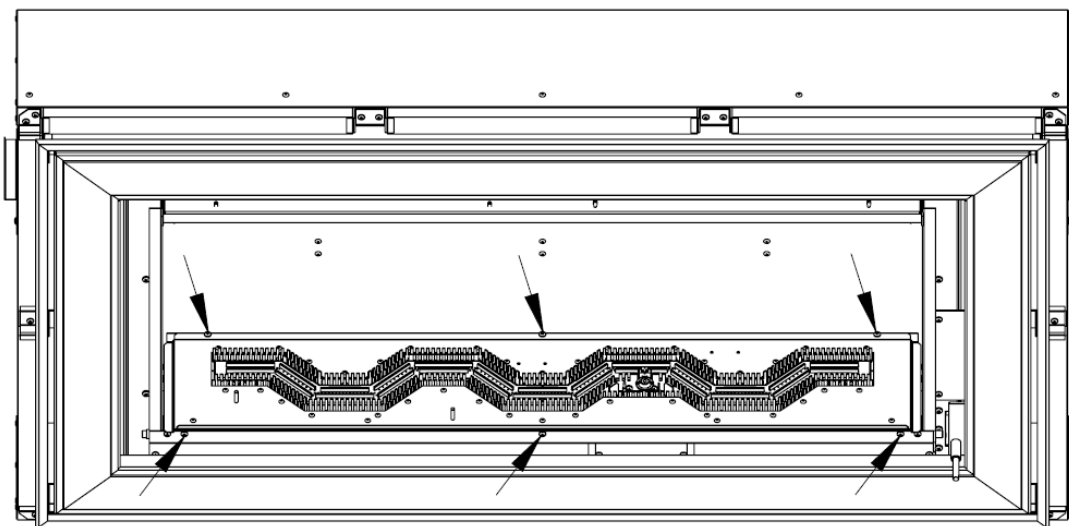

5. Remove the three screws and the burner can be released.

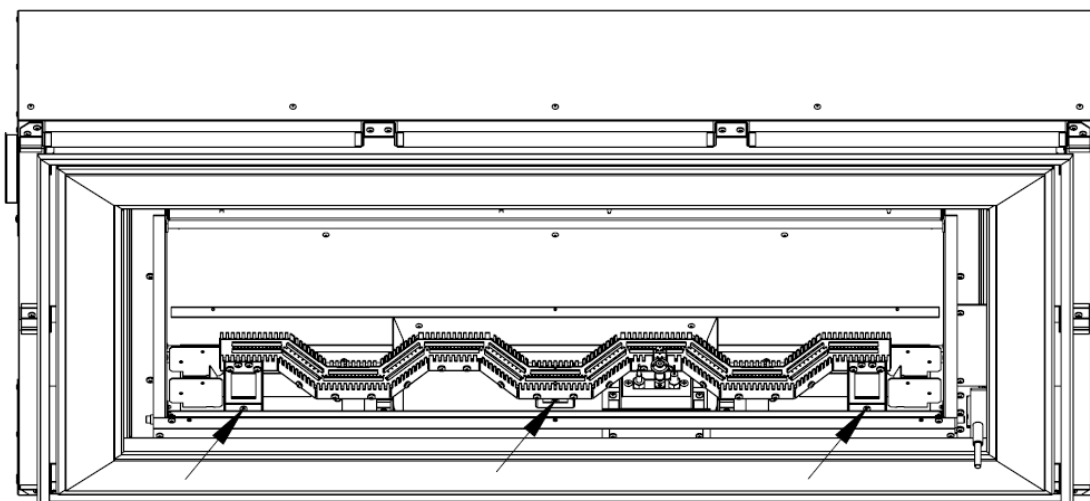

6. The injectors can now be removed.

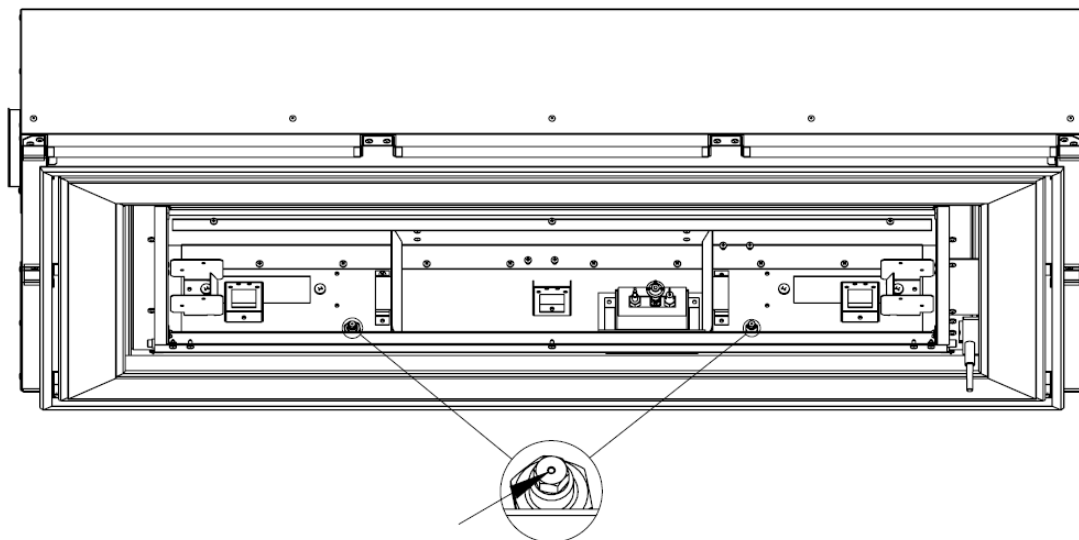

**Only replacement components supplied by the manufacturer should be used in the service of this appliance.
Contact details for Hearth Products Ltd can be found on the back page of these instructions.**





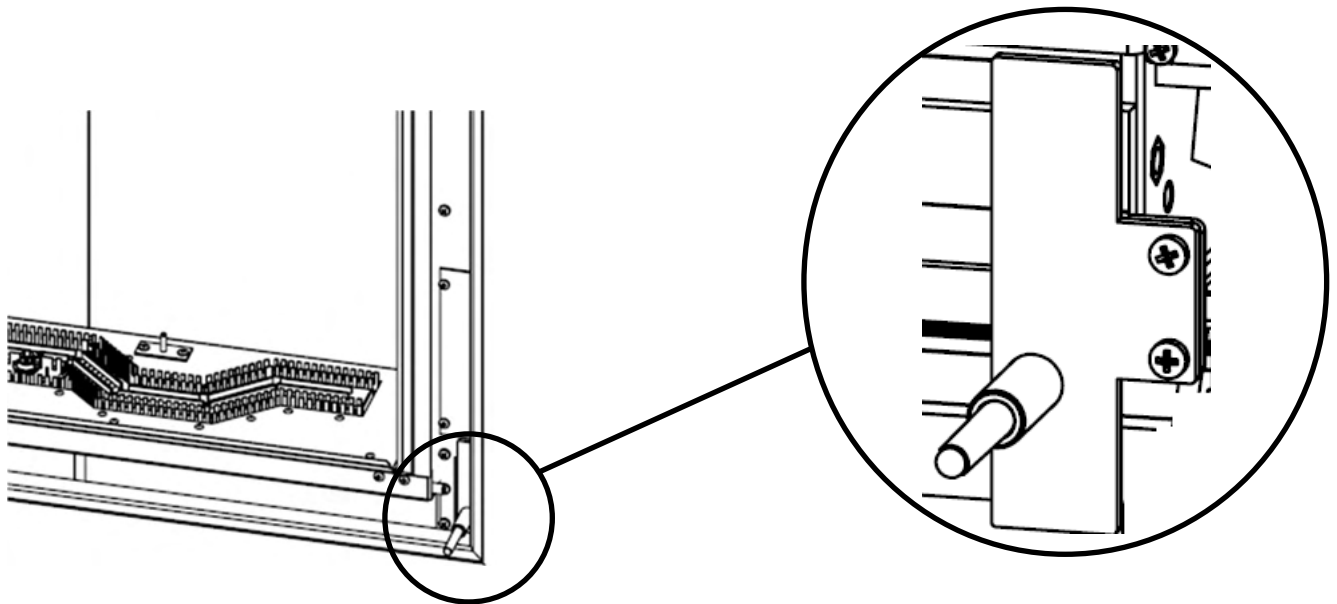

USER OPERATING INSTRUCTIONS

The appliance is operated using a slide lever which is concealed within the trim assembly to the lower right of the glass door.

Press the lever firmly with thumb or index finger and it will pop out towards you. The operation is detailed below. Once the appliance is set in the desired state, press the lever firmly inwards and it will return to the stowed position.



SLIDE CONTROL OPERATION

1. Push the control lever down fully to the IGN symbol . The spark generator should cause a repetitive spark at the pilot. The pilot and main burner (low setting) should ignite. If the pilot does not light after 10 seconds then lift the control lever upwards to the OFF symbol  and wait for 3 minutes.
2. Once the pilot and low burner are lit, keep the control lever pushed down fully for up to 10 seconds.
3. Now slowly lift the control lever to the  symbol, the pilot should remain lit and the burner will remain in the LOW setting. If it goes out, wait for 3 minutes and return to step 1.
4. To set the appliance to the HIGH setting, lift the control lever upwards to the  flame symbol.
5. It is also possible to adjust the control knob between the  and the  flame symbols to achieve a mid setting.
6. To turn the fire off, lift the lever to the  symbol to turn off.

IMPORTANT NOTE: Should the spark generator fail to provide a spark at the electrode it may be that a small amount of soot has fallen from the fuel bed onto the pilot assembly, causing a short circuit. If this is the case, ensuring the appliance is off and cold, this area can be cleaned with the thin nozzle from a vacuum cleaner. Alternatively check the battery is in good condition—the battery access cover is situated behind the trim on the right hand side. The trim must be removed to change the battery. See pages 6 and 21 of these instructions for details on how to remove and replace the trim assembly.

This glass panel on this appliance is very hot when in use and as with all heating appliances a fireguard should be used for the protection of children, the elderly and infirm. The fireguard should conform to BS8423 : 2002 (Fireguards or use with Gas Heating Appliances).

FUEL BED LAYOUT

The following instructions detail how the ceramic fuel components are to be installed onto the appliance. Great care should be taken when handling these ceramic parts as they are fragile and can easily be broken. Do not force any component into position, if it does not fit easily then you are not fitting the part correctly. These instructions can also be followed to remove or reinstall the fuel bed after cleaning. This is a procedure that can be undertaken by the customer as required and the frequency will depend upon use. **See page 6 for details on how to open and close the door.**

Fit the volcanic rock onto the burner as shown in the picture below.
Ensure that **NO VOLCANIC ROCK** is placed in the area shown in the white boxes.

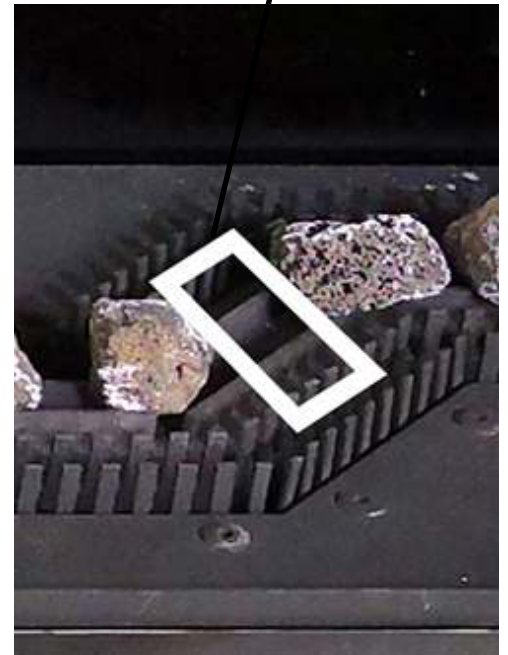

Ensure the secondary airways are not blocked by the volcanic rock

LOG IDENTIFICATION

Important note: the picture below shows each log and its identifying letter which should be used to place the logs detailed in the next few pages. There are two (2) LOG 'B' components which are identical. This is not a misprint.

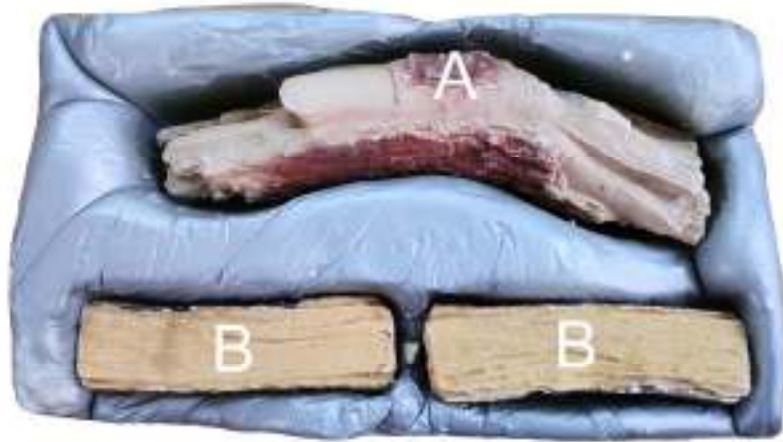

Identify and position log 'A' as shown in the picture



Identify and position log 'B' as shown in the picture below.



Identify and position log 'C' as shown in the picture below.



Identify and position the other log 'B' as shown in the picture below.



Identify and position log 'D' as shown in the picture below.



Identify and position log 'E' as shown in the picture below.



Identify and position log 'F' as shown in the picture below.



Identify and position log 'G' as shown in the picture below.



Identify and position log 'H' as shown in the picture below.



Identify and position log 'I' as shown in the picture below.



Identify and position log 'J' as shown in the picture below.



Identify and position log 'K' as shown in the picture below.



Identify and position log 'L' as shown in the picture below.



Identify and position log 'M' as shown in the picture below.



Place the ceramic bark around the ash pan base as shown below. Take care not to place any bark around the pilot burner assembly. Leave at least 5mm from any part of the pilot.



Refer to page 6 for details on how to secure the glass door once the logs and ceramics are in place.

APPLIANCE COMMISSIONING CHECKLIST

It is the installers responsibility to complete the following checklist when commissioning this appliance. The information recorded on this page may be requested at the time of any warranty call made. If the information is not made available it may affect the warranty support for the customers appliance.

CHECK LISTS	PASS	FAIL
Check flue is suitable for this appliance		
Check flue flow prior to installation		
Check spillage after installation		
Check standing gas pressure		mbar
Check working pressure on full rate (Min. 18.5) Ensure all other gas appliances are running on full rate		mbar
Complete relevant section of warranty forms , complete with Gas Safe registration details		
Instruct the customer on lighting, maintenance and servicing procedures. (Including glass removal and ceramic placement)		

Gas Engineer Name	
Gas Safe Engineer Registration No.	
Gas Safe Engineer contact No.	

If you can smell gas, immediately turn off the gas supply using the control valve at the meter in your home. Do not smoke and turn off all sources of ignition, i.e. boilers or gas hobs. Open windows and doors to ventilate the room or building.

Call the Gas Emergency Service 0800 111 999 (England Scotland and Wales)
0800 002 002 (N. Ireland)

Product Fiche	
Manufacturer :	Hearth Products Ltd
Model No.	F-111XX2
Fuel Type	Natural Gas I2H
Energy Efficiency Class	C
Indirect Heating Functionality	No
Direct Heat Output kW	4.6kW
Indirect Heat Output kW	N/A
EEl	77%
Useful Energy Efficiency (NCV)	High : 86%
Useful Energy Efficiency (NCV)	N/A
Nominal Heat Output	High : 4.6kW
Nominal Heat Output	Low : 2.1kW
Heat Output Temperature Control	Two Manual Stages
Permanent Pilot Power (kW)	N/A
Space Heating Emissions NOx (GCV)	130mg/kWh

Important Note:

The energy efficiency class of this product is defined using a seasonal efficiency calculation which reduces the actual net efficiency of the product where the use of automated heat control, thermostats, window open sensors and timers are not used. This is not to be confused with the net efficiency, or useful efficiency of the appliance (shown in the tables above).

**This product MUST be installed by a Gas Safe Registered Installer. Full details are provided in this manual.
Hearth Products Ltd. Unit 14 Tollgate Industrial Estate, Stafford, ST16 3SU**

User Replaceable Parts

Part Number	Description
P-XX1221-A	Ceramic Log A
P-XX1221-B	Ceramic Log B
P-XX1221-C	Ceramic Log C
P-XX1221-D	Ceramic Log D
Etc	
P-XX1222	Volcanic Rock Pack
P-XX1223	Ceramic Bark Pack



Hearth Products Ltd
Unit 14 Tollgate Industrial Estate,
Stafford, ST16 3SU

www.hearthproducts.co.uk

Tel: 01785 225401 Fax: 01785 225501

Email: info@hearthproducts.co.uk



Due to our policy of continual product improvement, some diagrams and small details may not be accurate however if there is any concern or matter of understanding that you feel needs to be clarified please contact us directly. Our contact details are shown above.